

SYSTEM GROUP

ROTOTEC
water saving solutions

PRE - EDITION
2026 GENERAL
CATALOGUE

—
TREATMENT
WATER TANKS
UNDERGROUND INSTALLATION



[ROTOTEC.IT/EN](https://rototec.it/en)

ENGLISH

THE PAST AND THE FUTURE

1999 Foundation of Rototec

2001 Rototec becomes part of the System Group

2004 First expansion of the production site and purchase of a machine to manufacture 3000 and 4000 litre tanks

2006 Second expansion of the production site and purchase of machines to manufacture 3500 and 5000 litre tanks

2008 Rototec wins and is awarded the UN contract

2009 Introduction of the INFINITANK range

2010 Increase in the INFINITANK manufacturing range volumes, third expansion and acquisition of a machine to manufacture 4500 litre tanks

2014 Introduction of PORTABLE SANITARY and MARINA SUPPLY COLUMNS ranges

2015 DEPURO range introduced (PIA certified waste water treatment plants)

2016 New Rototec Catalogue (March 2016)

2017 Fourth company expansion and office renovation

2018 Introduction of ORCIOTTO range and custom packaging system and storage expansion

2019-2020 New website and new Rototec catalogue (2021)

2020-2024 Design and presentation of the new EXAGON and VERTIGO product ranges, restyling of the website

COMING SOON Opening of the new operational and manufacturing headquarters



All the updated versions of our catalogue, including revisions and modifications, are available in the interactive catalogue on our website.



SEWAGE



WATER



UNDERGROUND INSTALLATION



- GREASE SEPARATORS
- IMHOFF BIOLOGICAL TANKS
- BIOLOGICAL SEPTIC TANKS
- ACTIVATED SLUDGE PLANT
- TRICKLE FILTERS
- SECONDARY TREATMENT PLANT
- DEPURBLOK
- DEPURO
- STORMWATER MANAGEMENT
- CAR WASH PLANTS
- LIFT STATIONS
- CHAMBERS
- TECHNICAL SECTION
- ABOVE-GROUND TANKS
- ABOVE-GROUND MODULAR FIREFIGHTING TANKS
- UNDERGROUND TANKS
- CONSTRUCTION SITE EQUIPMENT
- RAINWATER HARVESTING AND RE-USE SYSTEMS
- DEPURBLOK
- DEPURO
- CHAMBERS
- TECHNICAL SECTION
- ACCESSORIES
- UNDERGROUND INSTALLATION
- NON-STANDARD SOLUTIONS
- PORTABLE TOILETS
- OIL DISPOSAL UNIT

WE DESIGN, PLAN AND CREATE A SUSTAINABLE FUTURE BY REUSING WASTE AND IMPROVING LIVES.



SEWAGE



WATER



UNDERGROUND INSTALLATION



water saving solutions

SERVICES



SEWAGE



WATER



UNDERGROUND INSTALLATION



PEOPLE AND TECHNOLOGY AT THE SERVICE OF CUSTOMERS



Website



The group



Customer partnerships

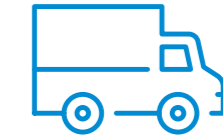

Transport

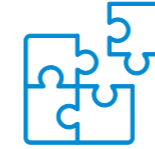

Training



Planning



Servicing



Prompt delivery



Commercial network



On-site support



BIM libraries



Web App

Digital design support thanks to tools such as:

- Organisation of educational sessions, technical seminars and on-site training
- A large network of agents and retailers throughout Italy and internationally
- Planning during the plant design phase
- Plant configuration software
- BIM libraries
- Website updated in real time
- Prompt delivery
- On-site technical support
- Post-sales support

THE GROUP

SYSTEM GROUP WORLDWIDE

[FIND OUT MORE](#)

SYSTEM GROUP

#wearesystemgroup

System Group is one of the leading groups in Italy and Europe in the supply of solutions to create fluid pipeline and cable protection networks, using PE, PP and PVC pipes, connectors and components.

Founded in 1979 by the entrepreneur Alvaro Boscarini in the province of Pesaro, the aim of the newly founded group was to offer high quality products and innovative solutions. Today, System Group has an integrated, local structure, providing its customers with design support, consultancy and advanced technical solutions.

Rototec - Lunano plant Manufacturing and assembly plant

5 PRODUCTION MACHINES 85 SITE STAFF

24,000m²
YARD SIZE

Rototec - Sant' Angelo in Vado plant Assembly plant

2 PRODUCTION MACHINES 25 SITE STAFF

6,000m²
YARD SIZE



SEWAGE



WATER



UNDERGROUND INSTALLATION



INTO THE FUTURE



SEWAGE



WATER



UNDERGROUND INSTALLATION

Rototec: water saving solutions.

Rototec works constantly to improve living conditions. Rototec's strength lies in its professional staff, who are committed to designing and creating technologically advanced products to meet customer needs.

We study the materials, shapes and design, which are fundamental to create functional, long-lasting, visually attractive products that are in harmony with the surrounding environment.



RESEARCH & DEVELOPMENT

Sustainable commitment.

We create sustainable solutions to optimise the efficiency of plants and reduce environmental impact, while fully complying with current regulations.

Through technological innovation and the use of materials containing a certain percentage of re-cycled product, in line with the UN 2030 Agenda's sustainable development goals, we guarantee the maximum performance and durability of our products, actively contributing to the shift to a circular economy. We have identified four key steps when creating plants that support sustainability.



NEW PRODUCTS



SEWAGE



WATER



UNDERGROUND INSTALLATION



SBR Sequencing Batch Reactor (Monobloc & Modular)

The monobloc and modular SBR system is a sequencing batch biological reactor designed for the treatment of domestic and industrial wastewater with variable load conditions. It is particularly suitable for installations in areas with limited available space.

The system integrates all treatment phases within a single tank, divided into a resting zone and an active zone. Aeration, provided by submerged diffusers, activates the activated sludge process and promotes solid-liquid separation.

The SBR operating cycle consists of four automatic phases:

- denitrification
- aeration
- sedimentation
- effluent extraction via an air-lift system



NEW PRODUCT RANGE 2025 - 2026

REGRIGIO GREYWATER TREATMENT SYSTEM "REGRIGIO"

The system collects and treats domestic greywater from washbasins, showers, and bathtubs through filtration and ultrafiltration processes.

The treated water can be reused for non-potable applications—such as irrigation and toilet flushing—contributing to water savings and environmental sustainability.

Thanks to its compact design, the greywater treatment unit can be installed in basements, garages, outdoor areas, or technical rooms of many single-family residential buildings.

Possible applications of treated greywater:

- Alimentation des WC Toilet flushing
- Washing machine supply
- Vehicle cleaning
- Garden irrigation





SEWAGE



WATER



UNDERGROUND INSTALLATION



RUBIKO Modular Rainwater Management System

Rubiko is a modular polypropylene system designed for stormwater management. It is available in three operational configurations, allowing adaptation to different geotechnical conditions and design requirements.

1. Soil infiltration

For permeable soils: enables controlled infiltration into the ground, promotes groundwater recharge, ensures hydraulic neutrality, reduces the load on drainage networks, and supports sustainable water management

2. Retention and controlled discharge

For low-permeability soils: when lined with non-woven geotextile (NWG) and HDPE geomembrane, the system becomes a watertight basin capable of storing stormwater and releasing it gradually through pipelines or pumping systems.

3. Collection and reuse

Using the same watertight configuration, the system can operate as a storage tank for non-potable applications, including irrigation, non-potable industrial uses, washing operations, and technical applications.

Technical specifications:

- Available heights: 60 cm / 90 cm
- Versions: LITE (pedestrian load) – MID (light traffic) – PRO (heavy loads)

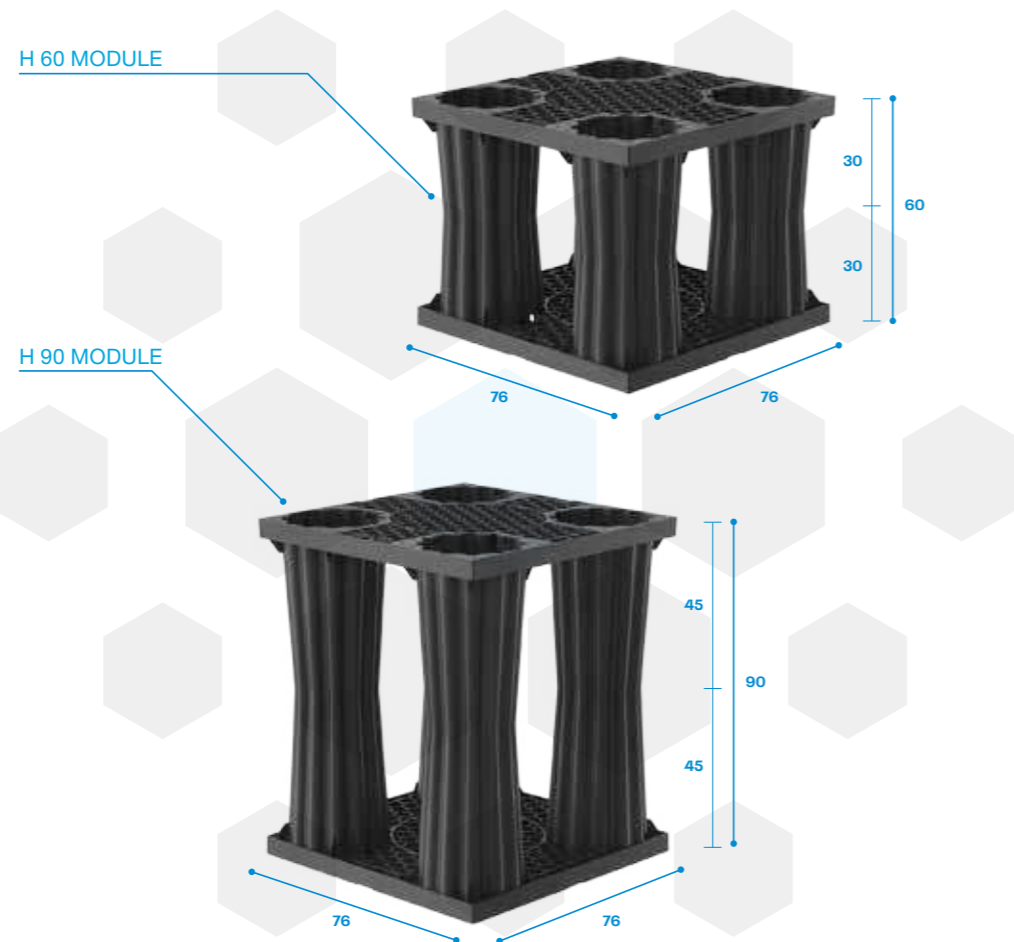

NEW KAR LINE

NEW DRIVEABLE MODULAR SYSTEM DESIGNED FOR DEEP EXCAVATIONS

The Infinitank KAR driveable modular line represents an advanced solution for the installation of storage tanks in deep excavations ranging from 40 to 150 cm, ensuring traffic resistance of up to 12 tonnes without the need for concrete slabs or reinforcement.

Developed by our technical team in collaboration with specialists in geology and geotechnical engineering, the system incorporates:

- FEM analyses
- Dedicated instrumented monitoring
- Applied geology studies to optimize performance

KEY FEATURES:

- High-performance polymer modules with excellent mechanical strength
- Available capacities from 11,000 to 40,000 litres
- Structure optimized for deep installations and high load conditions
- Suitable for civil and industrial applications
- Performance validated through over one year of on-site operational testing

DEDICATED BURIAL PROCEDURE:

- Method developed and certified through on-site testing
- Validation supported by applied geology experts and academic references
- Maximum safety and reliability throughout all installation phases



ROTOTEC



SEWAGE



WATER



UNDERGROUND
INSTALLATION



TRADE FAIR EVENTS



[FIND OUT MORE](#)

- GREASE SEPARATORS
- IMHOFF BIOLOGICAL TANKS
- BIOLOGICAL SEPTIC TANKS
- ACTIVATED SLUDGE PLANT
- TRICKLE FILTERS
- SECONDARY TREATMENT PLANT
- DEPURBLOK
- DEPURO
- STORMWATER MANAGEMENT
- CAR WASH PLANTS
- LIFT STATIONS
- CHAMBERS
- TECHNICAL SECTION
- NON-STANDARD SOLUTIONS
- ABOVE-GROUND TANKS
- ABOVE-GROUND MODULAR FIREFIGHTING TANKS
- UNDERGROUND TANKS
- CONSTRUCTION SITE EQUIPMENT
- OIL DISPOSAL UNIT
- PORTABLE TOILETS
- UNDERGROUND INSTALLATION
- ACCESSORIES



SEWAGE



WATER



UNDERGROUND INSTALLATION



- GREASE SEPARATORS
- IMHOFF BIOLOGICAL TANKS
- BIOLOGICAL SEPTIC TANKS
- ACTIVATED SLUDGE PLANT
- TRICKLE FILTERS
- SECONDARY TREATMENT PLANT
- DEPURBLOK
- DEPURO
- STORMWATER MANAGEMENT
- CAR WASH PLANTS
- LIFT STATIONS
- CHAMBERS
- TECHNICAL SECTION
- NON-STANDARD SOLUTIONS
- ABOVE-GROUND TANKS
- ABOVE-GROUND MODULAR FIREFIGHTING TANKS
- UNDERGROUND TANKS
- CONSTRUCTION SITE EQUIPMENT
- ACCESORIES
- UNDERGROUND INSTALLATION
- RAINWATER HARVESTING AND RE-USE SYSTEMS
- OIL DISPOSAL UNIT
- PORTABLE TOILETS

WATER TANKS



SEWAGE



WATER



UNDERGROUND INSTALLATION



SEWAGE



- TECHNICAL SECTION
- CHAMBERS
- LIFT STATIONS
- CHAMBERS
- CAR WASH PLANTS
- STORMWATER MANAGEMENT
- DEPURO
- RAINFALL HARVESTING AND RE-USE SYSTEMS
- DEPURBLOK
- UNDERGROUND TANKS
- SECONDARY TREATMENT PLANT
- TRICKLE FILTERS
- ACTIVATED SLUDGE PLANT
- ABOVE-GROUND MODULAR FIREFIGHTING TANKS
- BIOLOGICAL SEPTIC TANKS
- IMHOFF BIOLOGICAL TANKS
- GREASE SEPARATORS
- ABOVE-GROUND TANKS
- UNDERGROUND INSTALLATION
- ACCESSORIES
- CONSTRUCTION SITE EQUIPMENT
- OIL DISPOSAL UNIT
- PORTABLE TOILETS
- NON-STANDARD SOLUTIONS



SEWAGE



WATER



UNDERGROUND
INSTALLATION



SEWAGE

TECHNICAL SECTION

CHAMBERS

LIFT STATIONS

CAR WASH PLANTS

STORMWATER MANAGEMENT

DEPURO

DEPURBLOK

SECONDARY TREATMENT PLANT

TRICKLE FILTERS

ACTIVATED SLUDGE PLANT

BIOLOGICAL SEPTIC TANKS

IMHOFF BIOLOGICAL TANKS

GREASE SEPARATORS

NON-STANDARD SOLUTIONS

PORTABLE TOILETS

OIL DISPOSAL UNIT

CONSTRUCTION SITE EQUIPMENT

ACCESSORIES

UNDERGROUND INSTALLATION

TECHNICAL SECTION

CHAMBERS

CHAMBERS

STORMWATER MANAGEMENT

DEPURO

DEPURBLOK

SECONDARY TREATMENT PLANT

TRICKLE FILTERS

ACTIVATED SLUDGE PLANT

BIOLOGICAL SEPTIC TANKS

IMHOFF BIOLOGICAL TANKS

GREASE SEPARATORS

NON-STANDARD SOLUTIONS

PORTABLE TOILETS

OIL DISPOSAL UNIT

CONSTRUCTION SITE EQUIPMENT

ACCESSORIES

UNDERGROUND INSTALLATION



SEWAGE



WATER



UNDERGROUND
INSTALLATION



SEWAGE DIVISION

p. 24	PLANT SOLUTIONS
p. 26	GREASE SEPARATORS
p. 34	IMHOFF BIOLOGICAL TANKS
p. 38	BIOLOGICAL SEPTIC TANKS
p. 52	ACTIVATED SLUDGE PLANTS
p. 58	TRICKLE FILTERS
p. 70	SECONDARY TREATMENT PLANT WITH SLUDGE RECIRCULATION
p. 74	DEPURBLOK
p. 86	DEPURO
p. 94	GRIT SEPARATORS
p. 96	GRAVITY OIL SEPARATORS
p. 100	OIL SEPARATORS WITH COALESCING FILTER
p. 110	OIL SEPARATOR WITH COALESCING FILTER AND BY-PASS
p. 120	BALANCING TANKS
p. 128	PLANTS FOR CAR WASHES
p. 138	LIFT STATIONS
p. 154	CHAMBERS
p. 158	TECHNICAL SECTION

PLANT SOLUTIONS

ACCORDING TO THE LOCATION OF THE FINAL DISCHARGE POINT

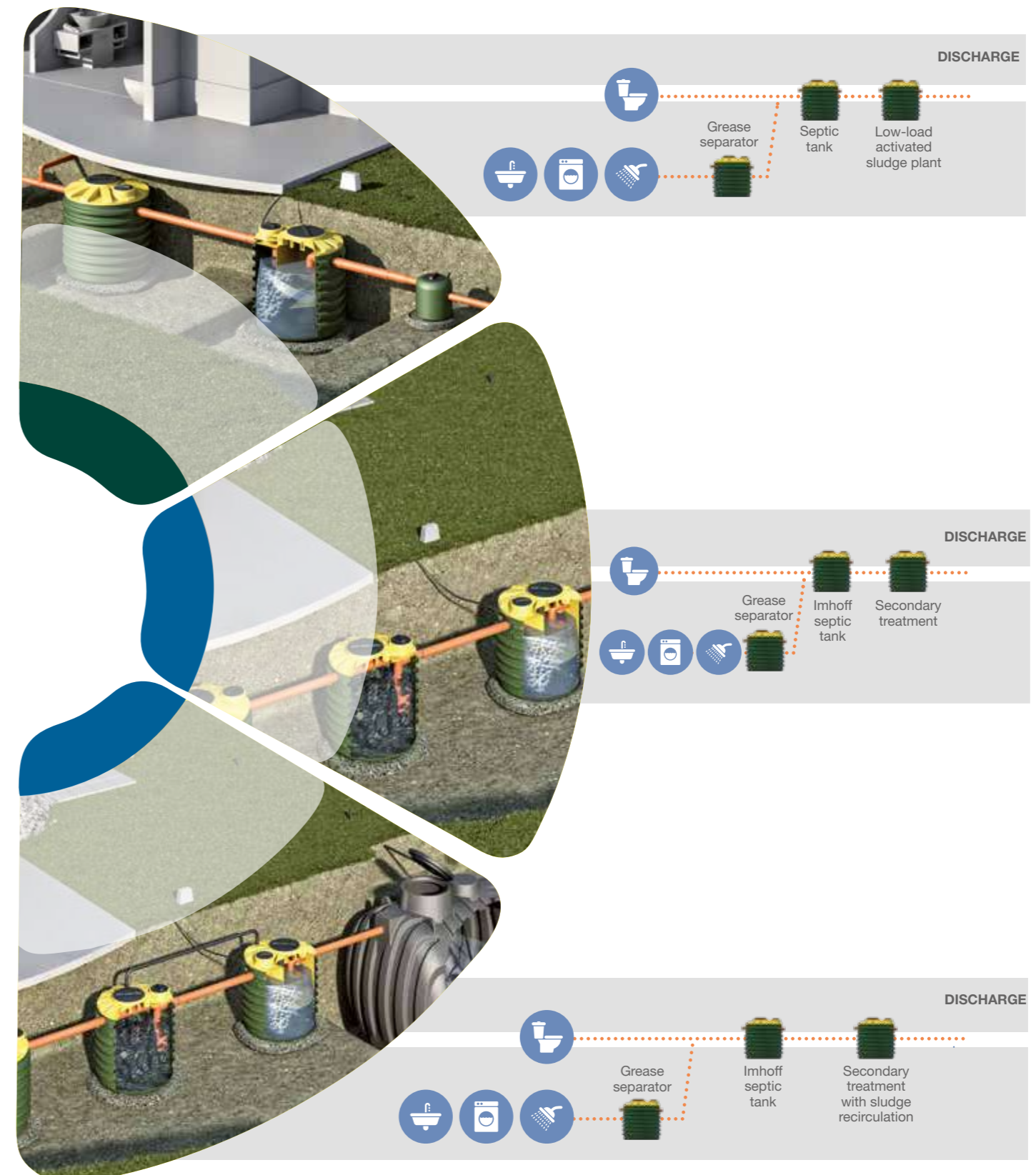
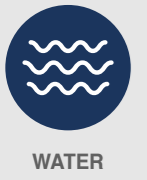

- GREASE SEPARATORS
- IMHOFF BIOLOGICAL TANKS
- BIOLOGICAL SEPTIC TANKS
- BIOLOGICAL SEPTIC TANKS
- ACTIVATED SLUDGE PLANT
- ABOVE-GROUND MODULAR FIREFIGHTING TANKS
- TRICKLE FILTERS
- SECONDARY TREATMENT PLANT
- DEPURBLOK
- DEPURO
- STORMWATER MANAGEMENT
- CAR WASH PLANTS
- LIFT STATIONS
- CHAMBERS
- TECHNICAL SECTION
- UNDERGROUND TANKS
- RAINWATER HARVESTING AND RE-USE SYSTEMS
- CHAMBERS
- TECHNICAL SECTION
- CONSTRUCTION SITE EQUIPMENT
- OIL DISPOSAL UNIT
- NON-STANDARD SOLUTIONS
- UNDERGROUND INSTALLATION
- ACCESSORIES

GREASE SEPARATORS

FIND OUT MORE



CE
UNI EN 1825-1



- 1 OILS AND GREASES**
Inlet zone in which the turbulence of the inlet flow is dampened and the substances with a specific weight lower than water (oils, foams, etc...) accumulate.
- 2 STILLING AREA**
Zone through which the separated and treated effluent flows.
- 3 SEDIMENTS**
Area in which temporary accumulation of the solids (food waste, etc...) takes place.



INSTALLATION DIAGRAM

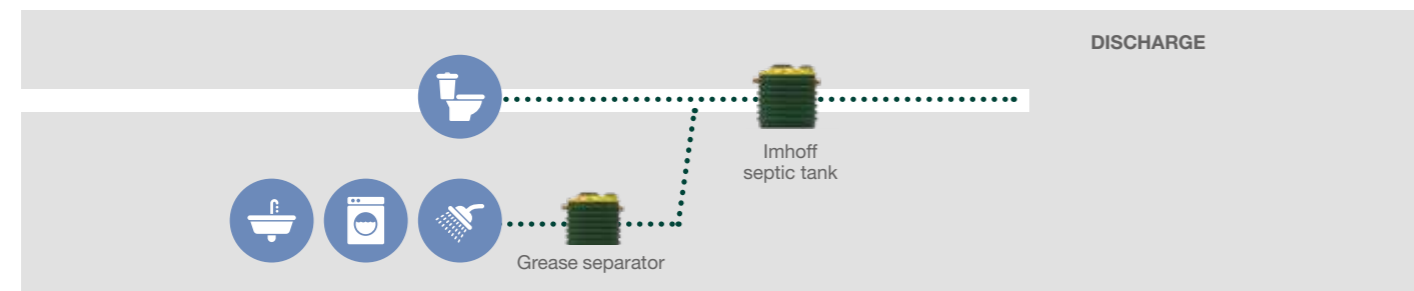

SPECIFICATIONS

TECHNICAL CHARACTERISTICS

The grease separator is a physical pre-treatment process that removes oils, foams, greases and all substances of specific weight less than that of the effluent.

The grease separator is nothing more than a stilling tank in which the substances of specific weight less than water are separated by floatation (upward flow to the surface). Sedimentation also takes place, with a part of the suspended solids depositing at the bottom of the tank.

USE

Treatment of grey water from kitchens, washbasins, bidets, showers, baths, washing machines and dishwashers.

REFERENCE STANDARDS

UNI EN 1825 - 1, Grease Separators

PRODUCT CERTIFICATION

UNI EN 1825-1 Grease separators.
Part 1: Principles of design, performance and testing, marking and quality control.
Excluding the modular range.

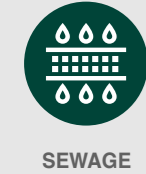

SEWAGE



WATER



UNDERGROUND INSTALLATION



GREASE SEPARATORS

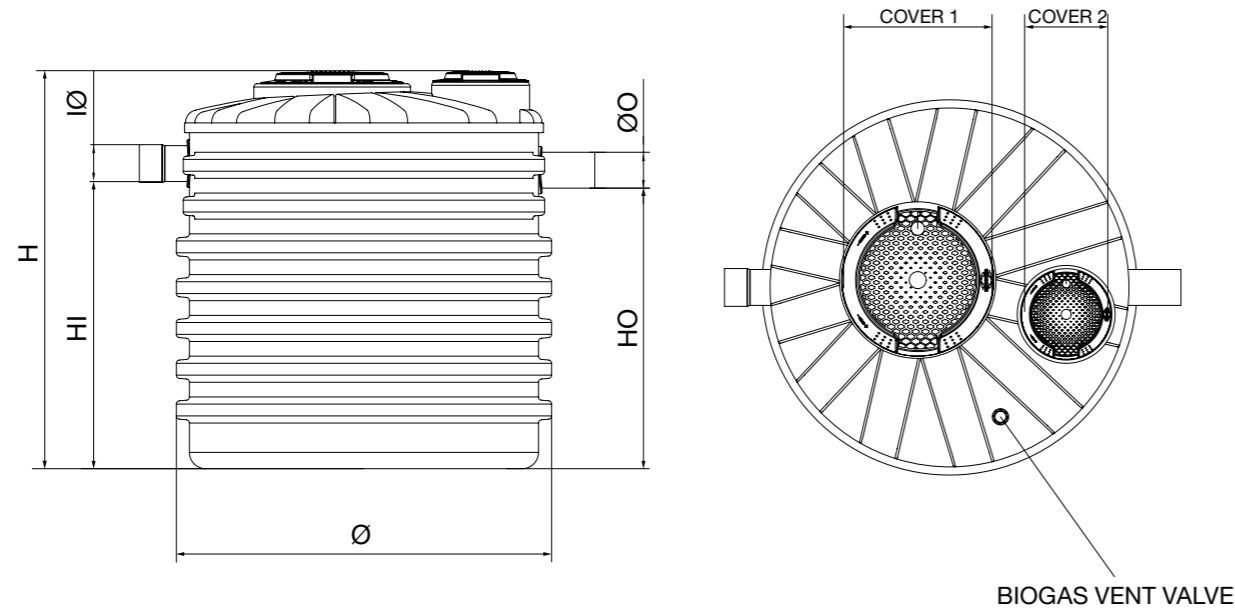

SEWAGE



WATER



UNDERGROUND INSTALLATION

MODULAR GREASE SEPARATORS

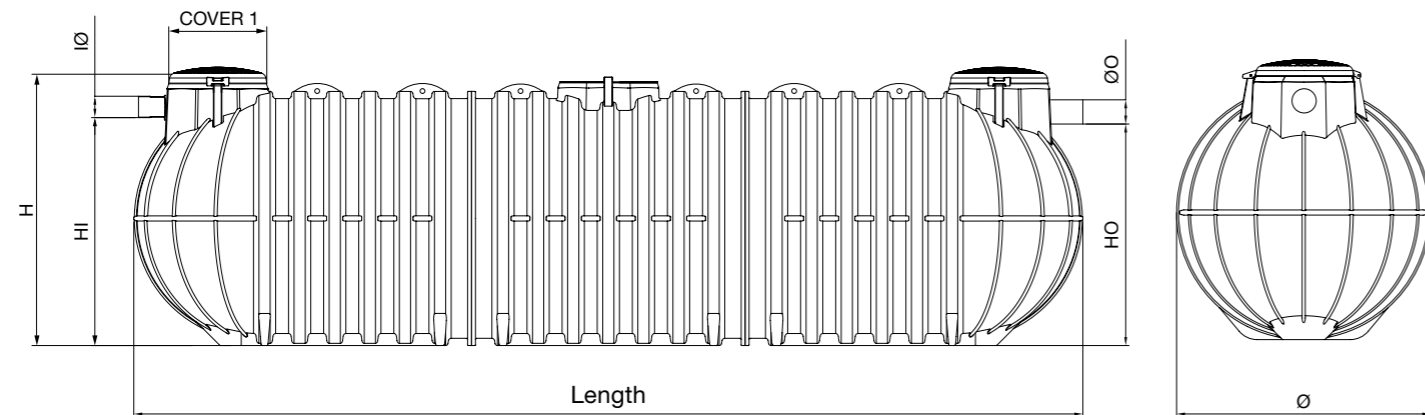

GREASE SEPARATORS

Item	Mod.	Length mm	Width mm	Ø mm	H mm	HI mm	HO mm	Ø I/O mm	Cover 1	Cover 2	Extension 1 (optional)	Extension 2 (optional)	Useful Vol. l	Grease Vol. l	Sed. vol. l	NS	P.E.
DD50		-	-	430	430	270	200	100	CC300	-	PP35	-	39	5	10	0.1	1
DD150		-	-	580	660	510	440	100	CC200	-	PP30	-	121	16	32	0.3	5
NDD150		950	650	-	565	375	345	100	CC200	CC130	PM30x30G	PM20x20G	180	25	35	0.4	7
DD300		-	-	630	970	770	700	100	CC200	-	PP30	-	218	30	59	0.5	10
NDD200		1000	635	-	675	490	440	100	CC200	CC130	PM30x30G	PM20x20G	205	30	50	0.5	10
NDD250		1050	663	-	720	540	500	100	CC200	CC130	PM30x30G	PM20x20G	258	35	70	0.6	12
NDD300		1100	700	-	775	585	535	100	CC200	CC130	PM30x30G	PM20x20G	303	40	80	0.7	15
XDD400		-	-	790	800	635	565	100	CC400	CC130C	PP45	-	272	28	72	0.72	15
DD800		1480	630	-	1090	870	800	110	CC300	CC200	PP35	PP30	693	80	180	1.8	20
NDD400		1150	750	-	890	695	645	100	CC200	CC130	PM30x30G	PM20x20G	409	55	110	1.0	20
XDD500		-	-	950	900	720	650	100	CC400	CC130C	PP45	-	445	48	120	1.2	23
NDD500		1400	900	-	750	560	530	100	CC200	CC130	PM30x30G	PM20x20G	510	75	140	1.2	25
XDD700		-	-	1150	923	630	560	110	CC400	CC200	PP45	PP30	577	60	152	1.52	28
XDD900		-	-	1150	1048	750	680	110	CC400	CC200	PP45	PP30	701	73	184	1.84	29
XDD1000		-	-	1150	1221	933	863	110	CC400	CC200	PP45	PP30	886	93	233	2.34	30
NDD1200		1900	708	-	1630	1250	1180	110	CC300	CC300	PP35	PP35	1142	120	300	3.0	35
XDD1250		-	-	1150	1478	1175	1105	110	CC400	CC200	PP45	PP30	1139	120	300	3.0	35
XDD1500		-	-	1150	1779	1465	1395	110	CC400	CC300	PP45	PP35	1444	152	380	3.8	42
NDD1700		1900	708	-	2140	1760	1690	110	CC300	CC300	PP35	PP35	1775	200	450	4.0	50
new XDD1750		-	-	1350	1672	1285	1215	110	CC400	CC300	PP45	PP35	1748	184	460	4.6	50
NDD2100		-	-	1350	1975	1540	1490	110	CC400	CC300	PP45	PP35	1850	260	550	4.0	60
NDD2600		-	-	1710	1450	1000	930	125	CC400	CC300	PP45	PP35	1971	220	550	5.0	70
NDD3200		-	-	1710	1725	1240	1170	125	CC400	CC300	PP45	PP35	2435	256	640	6.4	80
NDD3800		-	-	1710	1955	1480	1410	160	CC400	CC300	PP45	PP35	3026	330	800	7.9	90
NDD4600		-	-	1710	2225	1700	1630	160	CC400	CC300	PP45	PP35	3510	400	910	9.0	110
NDD5400		-	-	1950	2250	1630	1560	200	CC400	CC400	PP45	PP45	4152	462	1085	10.5	140
NDD6400		-	-	1950	2530	1940	1870	200	CC400	CC400	PP45	PP45	4862	495	1268	11.8	160
NDD7000		-	-	2250	2367	1810	1740	200	CC400	CC400	PP45	PP45	6711	900	1400	13.0	200
NDD9000		-	-	2250	2625	2030	1960	200	CC400	CC400	PP45	PP45	7534	1200	1800	15.5	250
NDD10700		2780	2430	-	2625	2270	2230	160	TAP800	-	PP77	-	10100	815	2040	20.0	300
ITDD13000		5010	-	2100	2200	1820	1750	200	TAP800	-	PP77	-	12105	1330	3020	30.0	340
ITDD15000		5620	-	2100	2200	1820	1750	200	TAP800	-	PP77	-	14150	1490	3720	37.2	400
ITDD18000		6680	-	2100	2200	1820	1750	200	TAP800	-	PP77	-	16900	1725	4320	43.0	475
ITDD20000		7270	-	2100	2200	1820	1750	200	TAP800	-	PP77	-	18610	1950	4870	48.7	540
ITDD22000		7880	-	2100	2200	1820	1750	200	TAP800	-	PP77	-	20700	2170	5450	54.5	600
ITDD25000		8940	-	2100	2200	1780	1710	250	TAP800	-	PP77	-	22800	2410	6010	60.1	640
ITDD28000		9530	-	2100	2200	1780	1710	250	TAP800	-	PP77	-	25200	2670	6620	66.1	700
ITDD30000		10140	-	2100	2200	1780	1710	250	TAP800	-	PP77	-	27250	2870	7170	71.7	800
ITDD33000		11200	-	2100	2200	1780	1710	250	TAP800	-	PP77	-	29540	3150	7710	77.2	825
ITDD35000		11790	-	2100	2200	1780	1710	250	TAP800	-	PP77	-	31710	3310	8250	82.5	885
ITDD36000		12400	-	2100	2200	1780	1710	250	TAP800	-	PP77	-	33800	3560	8890	88.9	1000
ITDD40000		13460	-	2100	2200	1780	1710	250	TAP800	-	PP77	-	36180	3820	9410	94.2	1150

[*] See the table on page 22 for sizing of grease separators for production activities (restaurants, hotels)

Sizing: 50 l/P.E. according to Emilia Romagna Regional Resolution No. 1053/03 and Umbria Regional Resolution No. 627/19, ARPA Guidelines Friuli-Venezia Giulia No. 40.01, Molise Regional Resolution No. 68/2015. P.E.= population equivalent; Ø= diameter; H= height; HI= inlet pipe height; HO= outlet pipe height; Ø I/O= inlet/outlet pipe diameter; NS= limit flow rate (l/s).

GREASE SEPARATOR FOR PRODUCTION ACTIVITIES (HOTELS AND RESTAURANTS)

Item	Useful volume	Grease volume	Sediment volume	NS	Hotel meals/day	Restaurant meals/day
DD50	39	5	10	0.1	7	7
DD150	121	16	32	0.3	25	20
NDD150	180	25	35	0.4	30	30
NDD200	205	30	50	0.5	36	35
NDD250	250	35	70	0.6	45	45
NDD300	303	40	80	0.7	50	48
XDD400	272	28	72	0.72	52	50
NDD400	409	55	110	1	75	70
XDD500	445	48	120	1.2	85	80
NDD500	510	75	140	1.2	90	85
XDD700	577	60	152	1.52	110	105
DD800	693	80	180	1.8	130	125
XDD900	701	73	184	1.84	140	135
XDD1000	886	93	233	2.34	150	140
NDD1200	1139	120	300	3.0	200	185
XDD1500	1444	152	380	3.8	230	215
NDD2100	1850	260	550	4.0	295	275
NDD1700	1775	200	450	4.0	290	270
XDD1750	1748	184	460	4.6	330	310
NDD2600	1971	220	550	5.0	360	345
NDD3200	2435	256	640	6.4	460	435
NDD3800	3026	330	800	7.9	560	535
NDD4600	3510	400	910	9.0	650	610
NDD5400	4152	462	1085	10.5	755	715
NDD6400	4862	495	1268	11.8	850	800
NDD7000	6711	900	1400	13.0	940	880
NDD9000	7534	1200	1800	15.5	1115	1050
NDD10700	10100	815	2040	20.0	1440	1355
ITDD13000	12105	1330	3020	30.0	2160	2035
ITDD15000	14150	1490	3720	37.2	2680	2520
ITDD18000	16900	1725	4320	43.0	3095	2915
ITDD20000	18610	1950	4870	48.7	3510	3300
ITDD22000	20700	2170	5450	54.5	3925	3695
ITDD25000	22800	2410	6010	60.1	4330	4075
ITDD28000	25200	2670	6620	66.1	4760	4480
ITDD30000	27250	2870	7170	71.7	5165	4860
ITDD33000	29540	3150	7710	77.2	5560	5230
ITDD35000	31710	3310	8250	82.5	5940	5590
ITDD36000	33800	3560	8890	88.9	6400	6025
ITDD40000	36180	3820	9410	94.2	6785	6385

NS= limit flow rate (l/s).

ABOVE-GROUND GREASE SEPARATORS

TECHNICAL CHARACTERISTICS

The grease separator is a physical pre-treatment process that removes oils, foams, greases and all substances of specific weight less than that of the effluent.

The grease separator is nothing more than a stilling tank in which the substances of specific weight less than water are separated by floatation (upward flow to the surface). Sedimentation also takes place, with a part of the suspended solids depositing at the bottom of the tank. Its reduced width allows it to be carried through doorways. In this way, it can be installed in a suitable utility room, cellar, etc.

The above-ground grease separators are designed to be floor mounted (not buried).

USE

Treatment of grey water from kitchens, washbasins, bidets, showers, baths, washing machines and dishwashers.

REFERENCE STANDARDS

UNI EN 1825-1 Grease separators.



- 1 VENT
PP vent pipe dia. 1" 1/2
- 2 LEVEL INDICATORS
Transparent grease level indicators.
- 3 TANK DRAIN
PP pipe union dia. 1"1/2 with ball valve.
- 4 ODOUR-PROOF SEAL
Threaded cover with gasket for sealing odours.

CE
UNI EN 1825-1

Item	Length mm	Width mm	H mm	HI mm	HO mm	Ø I/O mm	Cover 1	Cover 2	Useful Vol. l	Grease Vol. l	Sed. vol. l	NS	P.E.	Restaurant seating
EDD500	760	760	980	720	710	75	CC300	-	400	55	125	1	12	40
EDD1000	1500	680	1450	1310	1180	75	CC300	CC300	925	125	280	2	30	100
EDD2000	2330	680	1900	1750	1610	75	CC300	CC300	1820	210	550	4	60	180
EDD3000	2600	817	2000	1830	1760	75	CC300	CC300	2810	300	740	7.5	90	270

P.E.= population equivalent; Ø= diameter; H= height; HI= inlet pipe height; HO= outlet pipe height; Ø I/O= inlet/outlet pipe diameter; NS= limit flow rate (l/s).

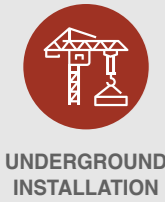
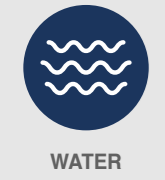

IMHOFF BIOLOGICAL TANKS

FIND OUT MORE



SEWAGE



WATER



UNDERGROUND INSTALLATION



CE
UNI EN 12566-3



- 1 OILS AND GREASES
Sedimentation area for incoming solids.
- 2 DIGESTION
Area in which the digestion takes place and the treated effluent flows out.
- 3 SLUDGE
Area in which the biological sludge responsible for treatment of the effluent is formed.



INSTALLATION DIAGRAM

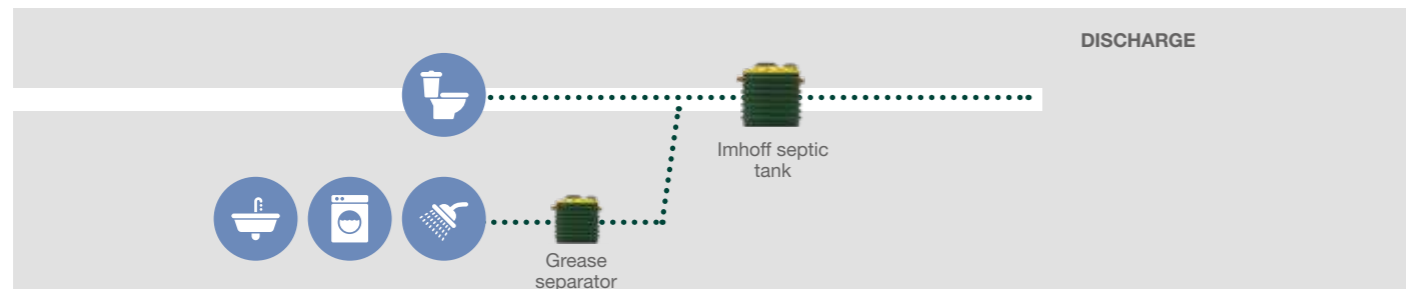

SPECIFICATIONS

TECHNICAL CHARACTERISTICS

Imhoff septic tanks consist of two overlapping and hydraulically communicating compartments. In the upper compartment the sedimentable solids fall to the bottom of the sedimentation chamber by gravity. The chamber is suitably inclined to allow the sludge to pass into the lower compartment where digestion takes place.

USE

Primary treatment of sewage from toilets.

REFERENCE STANDARDS

UNI EN 12566-3



ROTOTEC 35

IMHOFF BIOLOGICAL TANKS

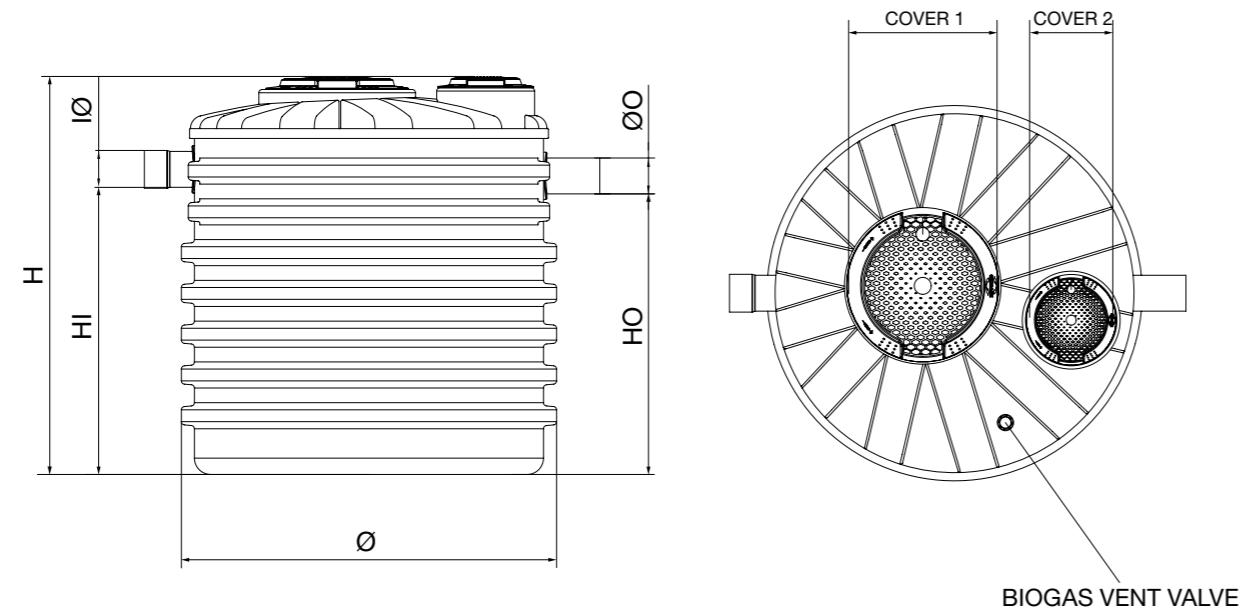

MODULAR IMHOFF BIOLOGICAL TANKS

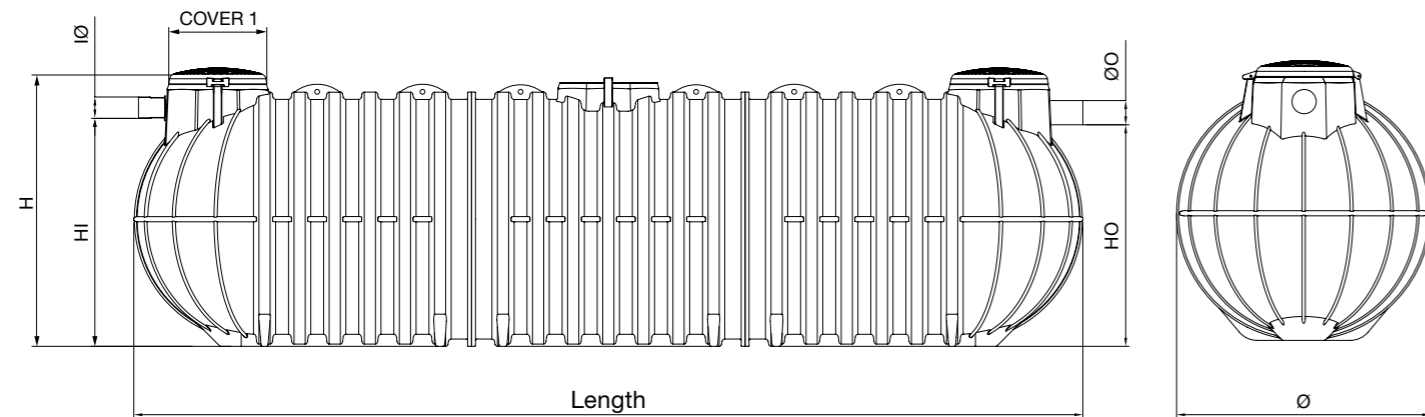

Item	Mod.	Length mm	Width mm	Ø mm	H mm	HI mm	HO mm	Ø I/O mm	Cover 1	Cover 2	Extension 1 (optional)	Extension 2 (optional)	Sed. vol. l	Digester Vol. l	Tot. vol. l	Organic load *KgBOD5-d	Hydraulic load m ³ /d	P.E.
XIM400		-	-	790	850	635	615	110	CC300	CC130C	PP35	-	80	200	280	0.12	0.4	2
XIM500		-	-	950	900	720	700	110	CC400	CC130C	PP45	PP30	121	342	463	0.18	0.6	3
XIM700		-	-	1150	923	630	610	110	CC400	CC200	PP45	PP30	160	406	566	0.24	0.8	4
XIM900		-	-	1150	1048	750	730	110	CC400	CC200	PP45	PP30	200	500	700	0.3	1	5
XIM1000		-	-	1150	1221	933	913	110	CC400	CC200	PP45	PP30	260	628	888	0.36	1.2	6
NIM1200		1900	708	/	1630	1250	1230	110	CC300	CC300	PP35	PP35	290	910	1200	0.42	1.4	7
XIM1250		-	-	1150	1478	1175	1155	110	CC400	CC200	PP45	PP30	320	800	1120	0.48	1.6	8
XIM1500		-	-	1150	1779	1465	1445	110	CC400	CC300	PP45	PP35	384	1000	1384	0.54	1.8	9
new XIM1750		-	-	1350	1672	1285	1265	110	CC400	CC300	PP45	PP45	450	1195	1645	0.66	2.2	11
NIM1700		1900	708	/	2140	1760	1740	110	CC300	CC300	PP35	PP35	412	1363	1775	0.72	2.4	12
NIM2100		-	-	1350	1975	1540	1520	110	CC400	CC300	PP45	PP35	480	1470	1950	0.78	2.6	13
NIM2600		-	-	1710	1450	1000	980	125	CC400	CC300	PP45	PP35	629	1432	2061	0.84	2.8	14
NIM3200		-	-	1710	1725	1240	1220	125	CC400	CC300	PP45	PP35	760	1765	2525	1.08	3.6	18
NIM3800		-	-	1710	1955	1490	1470	160	CC400	CC300	PP45	PP35	965	2139	3104	1.32	4.4	22
NIM4600		-	-	1710	2225	1710	1690	160	CC400	CC300	PP45	PP35	1085	2713	3798	1.62	5.4	27
NIM5400		-	-	1950	2250	1660	1640	160	CC400	CC400	PP45	PP45	1210	3137	4347	1.86	6.2	31
NIM6400		-	-	1950	2530	1970	1950	160	CC400	CC400	PP45	PP45	1322	3778	5100	2.16	7.2	36
MTIM6000		3870	-	1550	1710	1420	1400	160	TAP800	/	PP77	-	1660	4030	5690	2.4	8	40
NIM7000		-	-	2250	2367	1850	1830	160	CC400	CC400	PP45	PP45	1460	5474	6934	2.88	9.6	48
NIM9000		-	-	2250	2625	2070	2050	160	CC400	CC400	PP45	PP45	2020	5803	7823	3.24	10.8	54
NIM9800		-	-	2270	2850	2320	2300	160	CC400	CC400	PP45	PP45	1780	7040	8820	3.72	12.4	62
ITIM11000		4420	-	2100	2200	1870	1840	160	TAP800	/	PP77	-	2910	7225	10135	4.32	14.4	72
MTIM12000		7180	-	1550	1710	1420	1400	160	TAP800	/	PP77	-	3240	8066	11306	4.8	16	80
ITIM13000		5010	-	2100	2200	1870	1840	160	TAP800	/	PP77	-	3495	8610	12105	5.16	17.2	86
ITIM15000		5620	-	2100	2200	1870	1840	160	TAP800	/	PP77	-	4070	10080	14150	6	7.2	100
ITIM18000		6680	-	2100	2200	1870	1840	160	TAP800	/	PP77	-	4820	12142	16922	7.2	24	120
ITIM20000		7270	-	2100	2200	1830	1800	200	TAP800	/	PP77	-	5330	13280	18610	7.29	26.4	132
ITIM22000		7880	-	2100	2200	1870	1840	160	TAP800	/	PP77	-	5710	15020	20730	8.88	29.6	148
ITIM25000		8940	-	2100	2200	1870	1840	160	TAP800	/	PP77	-	6575	16410	22985	9.84	32.8	164
ITIM28000		9530	-	2100	2200	1870	1840	160	TAP800	/	PP77	-	7240	18030	25270	10.8	36	180
ITIM30000		10140	-	2100	2200	1830	1800	200	TAP800	/	PP77	-	7690	19560	27250	11.4	38	190
ITIM33000		11200	-	2100	2200	1830	1800	200	TAP800	/	PP77	-	8440	21100	29630	12.6	42	210
ITIM35000		11790	-	2100	2200	1830	1800	200	TAP800	/	PP77	-	9040	22670	31710	13.5	45	225
ITIM36000		12400	-	2100	2200	1830	1800	200	TAP800	/	PP77	-	9680	24120	33800	14.4	48	240
ITIM40000		13460	-	2100	2200	1830	1800	200	TAP800	/	PP77	-	10370	25810	36180	15.48	51.6	258

P.E.= population equivalent; Ø= diameter; H= height; HI= inlet pipe height; HO= outlet pipe height; Ø I/O= inlet/outlet pipe diameter.



SEWAGE



WATER



UNDERGROUND INSTALLATION



GREASE SEPARATORS
IMHOFF BIOLOGICAL TANKS
BIOLOGICAL SEPTIC TANKS
ACTIVATED SLUDGE PLANT
TRICKLE FILTERS
SECONDARY TREATMENT PLANT
DEPURBLOK
DEPURO
STORMWATER MANAGEMENT
CAR WASH PLANTS
LIFT STATIONS
CHAMBERS
TECHNICAL SECTION

ABOVE-GROUND TANKS
ABOVE-GROUND MODULAR FIREFIGHTING TANKS
UNDERGROUND TANKS
CONSTRUCTION SITE EQUIPMENT
RAINWATER HARVESTING AND RE-USE SYSTEMS
OIL DISPOSAL UNIT
PORTABLE TOILETS
NON-STANDARD SOLUTIONS

BIOLOGICAL SEPTIC TANKS

FIND OUT MORE



CE
UNI EN 12566-1



SEWAGE



WATER



UNDERGROUND INSTALLATION

- 1 STILLING ZONE**
Area in which the incoming effluent slows down, allowing sludge to settle and any lighter substances to separate.
- 2 SLUDGE**
The separated sludge accumulates on the bottom of the tank, and undergoes anaerobic digestion by the bacterial flora.



INSTALLATION DIAGRAM

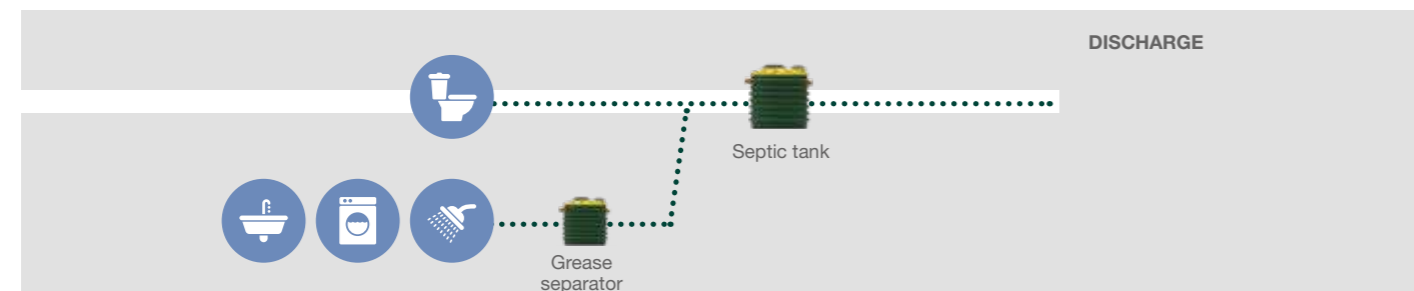

SPECIFICATIONS

TECHNICAL CHARACTERISTICS

Biological Septic tanks constitute a reliable device for the primary treatment of sewage. The treatment systems are passive, extremely stable, simple and inexpensive. They are used, above all, for treating domestic sewage from small communities. The configuration of the tank forces the sewage to pass through the liquid mass contained in it. The slowing down of the flow allows sedimentable solids and substances of specific weight less than that of the water to separate. Furthermore, an anaerobic fermentation process is triggered with the resulting solubilisation and synthesis of part of the suspended solids. In this way, the effluent leaving the tank is conditioned, i.e. it has a limited concentration of solids, transformed for the most part into dissolved and colloidal solids.

TYPES

Single chamber, two-chamber and three-chamber

USE

Primary treatment of sewage from toilets.

REFERENCE STANDARDS

UNI EN 12566-1.

PRODUCT CERTIFICATION

UNI EN 12566-1 small waste water treatment systems of up to 50 PT.
Part 1: Prefabricated septic tanks.



ROTOTEC 39

SINGLE-CHAMBER BIOLOGICAL SEPTIC TANKS

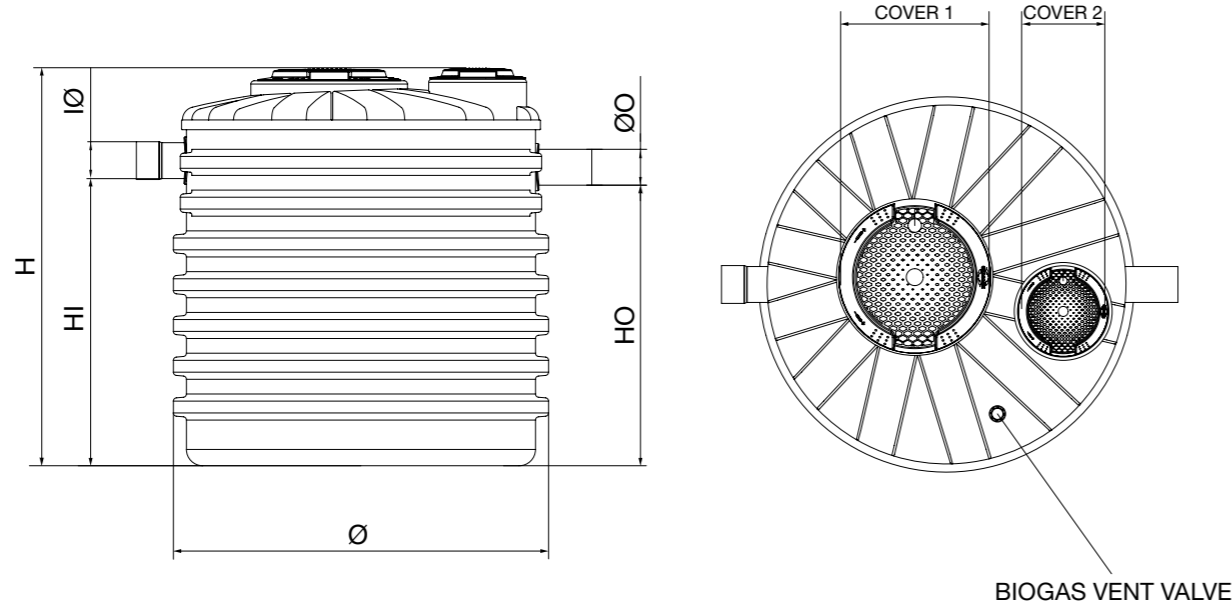

SINGLE-CHAMBER BIOLOGICAL SEPTIC TANKS

Item	Mod.	Length mm	Width mm	Ø mm	H mm	HI mm	HO mm	Ø I/O mm	Cover 1	Cover 2	Extension 1 (optional)	Extension 2 (optional)	Useful volume l	P.E.
XSE400		-	-	790	800	635	615	110	CC400	CC130C	PP45	-	271	2
XSE500		-	-	950	900	720	700	110	CC400	CC130C	PP45	-	463	3
XSE700		-	-	1150	923	630	610	110	CC400	CC200	PP45	PP30	566	4
XSE900		-	-	1150	1048	750	730	110	CC400	CC200	PP45	PP30	700	5
XSE1000		-	-	1150	1221	933	913	110	CC400	CC200	PP45	PP30	888	7
XSE1250		-	-	1150	1478	1175	1155	110	CC400	CC200	PP45	PP30	1090	9
NSE1200		1900	708	/	1630	1250	1230	110	CC300	CC300	PP35	PP35	1200	9
XSE1500		-	-	1150	1779	1465	1445	110	CC400	CC300	PP45	PP35	1384	11
new XSE1750		-	-	1350	1672	1285	1265	110	CC400	CC300	PP45	PP35	1645	12
NSE1700		1900	708	/	2140	1760	1740	110	CC300	CC300	PP35	PP35	1775	13
NSE2100		-	-	1350	1975	1540	1520	110	CC400	CC300	PP45	PP35	1950	15
NSE2600		-	-	1710	1450	1000	980	125	CC400	CC300	PP45	PP35	2061	16
NSE3200		-	-	1710	1725	1240	1220	125	CC400	CC300	PP45	PP35	2525	20
NSE3800		-	-	1710	1955	1525	1505	125	CC400	CC300	PP45	PP35	3175	24
NSE4600		-	-	1710	2225	1745	1725	125	CC400	CC300	PP45	PP35	3835	30
NSE5400		-	-	1950	2250	1700	1680	125	CC400	CC400	PP45	PP45	4578	36
NSE6400		-	-	1950	2530	2000	1980	125	CC400	CC400	PP45	PP45	5293	42
NSE7000		-	-	2250	2367	1850	1830	160	CC400	CC400	PP45	PP45	6934	55
NSE9000		-	-	2250	2625	2070	2050	160	CC400	CC400	PP45	PP45	7823	70
NSE10700		2780	2430	/	2625	2270	2230	160	TAP800	/	PP77	-	10100	100
ITSE13000		5010	-	2100	2200	1870	1850	160	TAP800	/	PP77	-	12105	120
ITSE15000		5620	-	2100	2200	1870	1850	160	TAP800	/	PP77	-	14150	140
ITSE18000		6680	-	2100	2200	1870	1850	160	TAP800	/	PP77	-	16900	165
ITSE20000		7270	-	2100	2200	1850	1830	200	TAP800	/	PP77	-	18610	185
ITSE22000		7880	-	2100	2200	1850	1830	200	TAP800	/	PP77	-	20700	200
ITSE25000		8940	-	2100	2200	1850	1830	200	TAP800	/	PP77	-	22800	225
ITSE28000		9530	-	2100	2200	1850	1830	200	TAP800	/	PP77	-	25200	250
ITSE30000		10140	-	2100	2200	1820	1800	250	TAP800	/	PP77	-	27250	270
ITSE33000		11200	-	2100	2200	1820	1800	250	TAP800	/	PP77	-	29540	290
ITSE35000		11790	-	2100	2200	1820	1800	250	TAP800	/	PP77	-	31710	310
ITSE36000		12400	-	2100	2200	1820	1800	250	TAP800	/	PP77	-	33800	330
ITSE40000		13460	-	2100	2200	1820	1800	250	TAP800	/	PP77	-	36180	360

MODULAR SINGLE-CHAMBER BIOLOGICAL SEPTIC TANKS

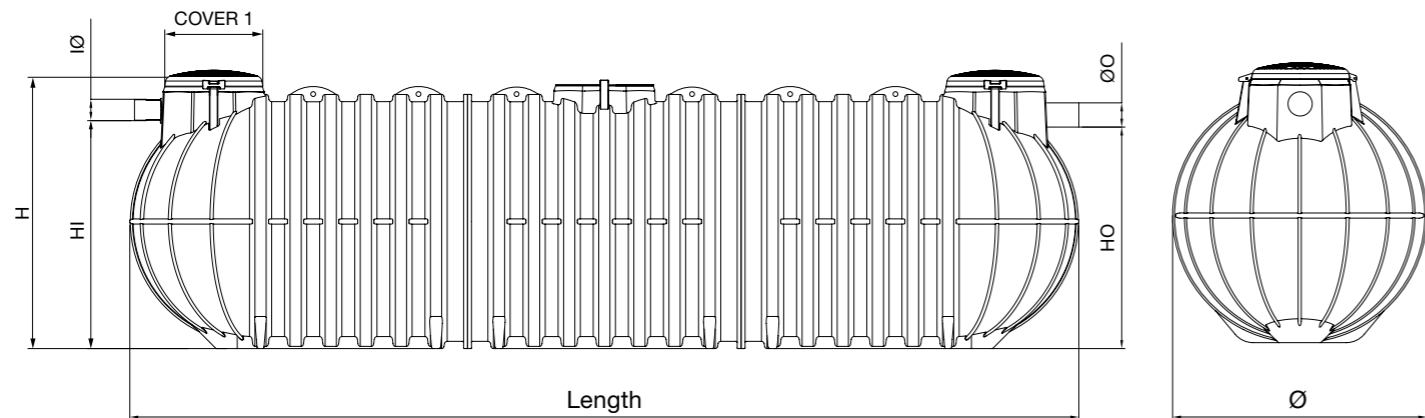

* When sizing the septic tank using a pro capita volume of 100 l / P.E. it is necessary to pump out the tank 3-4 times a year.

P.E.= population equivalent; Ø= diameter; H= height; HI= inlet pipe height; HO= outlet pipe height; Ø I/O= inlet/outlet pipe diameter.

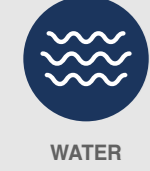
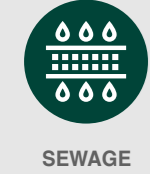

TWO-CHAMBER BIOLOGICAL SEPTIC TANKS

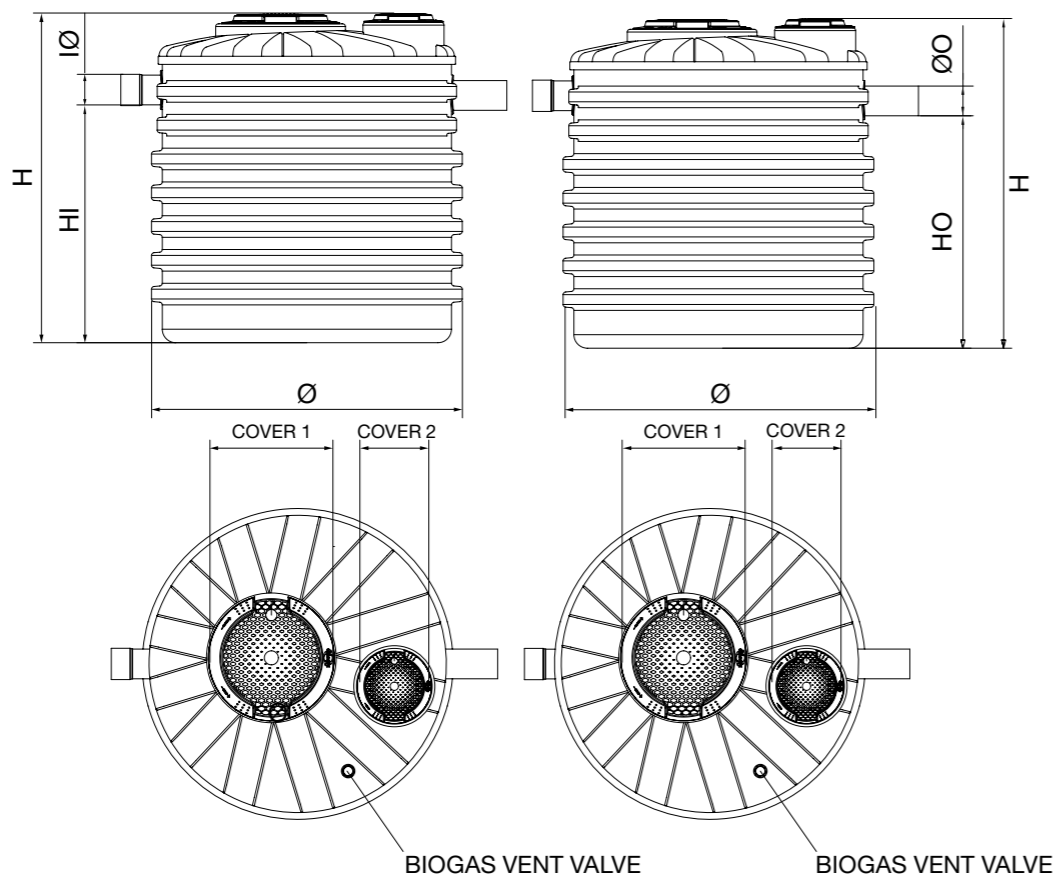

TWO-CHAMBER BIOLOGICAL SEPTIC TANKS

Item	Mod.	Length mm	Width mm	Ø mm	H mm	HI mm	HO mm	Ø I/O mm	Cover 1	Cover 2	Extension 1 (optional)	Extension 2 (optional)	Useful Volume l	P.E.
SEB500X2		-	-	790	800	635	315	110	CC400	CC130C	PP45	-	542	4
XSEB500X2		-	-	950	900	720	700	110	CC400	CC130C	PP45	-	926	6
XSEB700X2		-	-	1150	923	630	610	110	CC400	CC200	PP45	PP30	1132	8
XSEB900X2		-	-	1150	1048	750	730	110	CC400	CC200	PP45	PP30	1400	10
XSEB1000X2		-	-	1150	1221	933	913	110	CC400	CC200	PP45	PP30	1776	14
NSEB1200X2		1900	708	-	1630	1250	1230	110	CC300	CC300	PP35	PP35	2400	18
XSEB1250X2		-	-	1050	1478	1175	1155	110	CC400	CC200	PP45	PP30	2180	18
XSEB1500X2		-	-	1150	1779	1465	1445	110	CC400	CC300	PP45	PP35	2768	22
new XSEB1750X2		-	-	1350	1672	1285	1265	110	CC400	CC300	PP45	PP35	3290	24
NSEB1700X2		1900	708	-	2140	1760	1740	110	CC300	CC300	PP35	PP35	3550	26
NSEB2100X2		-	-	1350	1975	1540	1520	110	CC400	CC300	PP45	PP35	3900	30
NSEB2600X2		-	-	1710	1450	1000	980	125	CC400	CC300	PP45	PP35	4122	32
NSEB3200X2		-	-	1710	1725	1240	1220	125	CC400	CC300	PP45	PP35	5050	40
NSEB3800X2		-	-	1710	1955	1525	1505	125	CC400	CC300	PP45	PP35	6350	48
NSEB4600X2		-	-	1710	2225	1745	1725	125	CC400	CC300	PP45	PP35	7670	60
NSEB5400X2		-	-	1950	2250	1700	1680	125	CC400	CC400	PP45	PP45	9156	72
NSEB6400X2		-	-	1950	2530	2000	1980	125	CC400	CC400	PP45	PP45	10586	84
NSEB7000X2		-	-	2250	2367	1850	1830	160	CC400	CC400	PP45	PP45	13868	110
NSEB9000X2		-	-	2250	2625	2070	2050	160	CC400	CC400	PP45	PP45	15646	140

MODULAR TWO-CHAMBER BIOLOGICAL SEPTIC TANKS

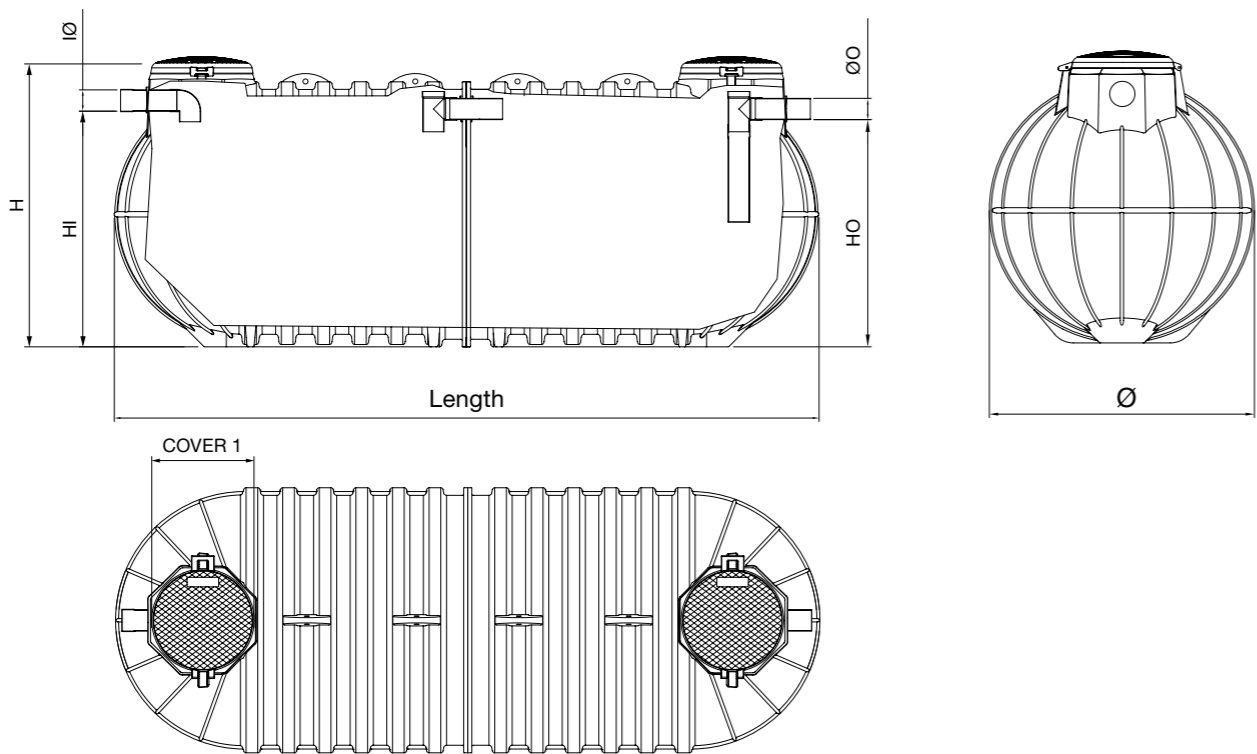

MODULAR TWO-CHAMBER BIOLOGICAL SEPTIC TANKS

Item	Mod.	Length mm	Ø mm	H mm	HI mm	HO mm	Ø I/O mm	Covers	Extension	Section 1 volume l	Section 2 volume l	Overall useful volume l	P.E.
NTSEB2000	nanotank	2350	1150	1320	960	940	125	TAP800	PP77	910	910	1820	15
NTSEB3000	nanotank	3420	1150	1320	960	940	125	TAP800	PP77	1820	910	2730	22
NTSEB4000	nanotank	4500	1150	1320	960	940	125	TAP800	PP77	1820	1820	3640	30
NTSEB5000	nanotank	5570	1150	1320	960	940	125	TAP800	PP77	2730	1820	4550	40
NTSEB6000	nanotank	6650	1150	1320	960	940	125	TAP800	PP77	2730	2730	5460	45
MTSEB6000	minitank	3870	1550	1710	1400	1380	160	TAP800	PP77	2900	2900	5800	55
MTSEB9000	minitank	5520	1550	1710	1400	1380	160	TAP800	PP77	5800	2900	8700	85
MTSEB12000	minitank	7180	1550	1710	1400	1380	160	TAP800	PP77	5800	5800	11600	105
ITSEB15000	infinitant	5620	2100	2200	1870	1850	160	TAP800	PP77	7000	7000	14000	140
ITSEB20000	infinitant	7270	2100	2200	1850	1830	200	TAP800	PP77	12000	7000	19000	180
ITSEB25000	infinitant	8940	2100	2200	1850	1830	200	TAP800	PP77	12000	12000	24000	230
ITSEB30000	infinitant	10140	2100	2200	1850	1830	200	TAP800	PP77	14000	14000	28000	270
ITSEB36000	infinitant	12400	2100	2200	1850	1830	200	TAP800	PP77	21000	14000	35000	330
ITSEB40000	infinitant	13460	2100	2200	1850	1830	200	TAP800	PP77	19000	19000	38000	370

P.E.= population equivalent; Ø= diameter; H= height; HI= inlet pipe height; HO= outlet pipe height; Ø I/O= inlet/outlet pipe diameter.

THREE-CHAMBER BIOLOGICAL SEPTIC TANKS

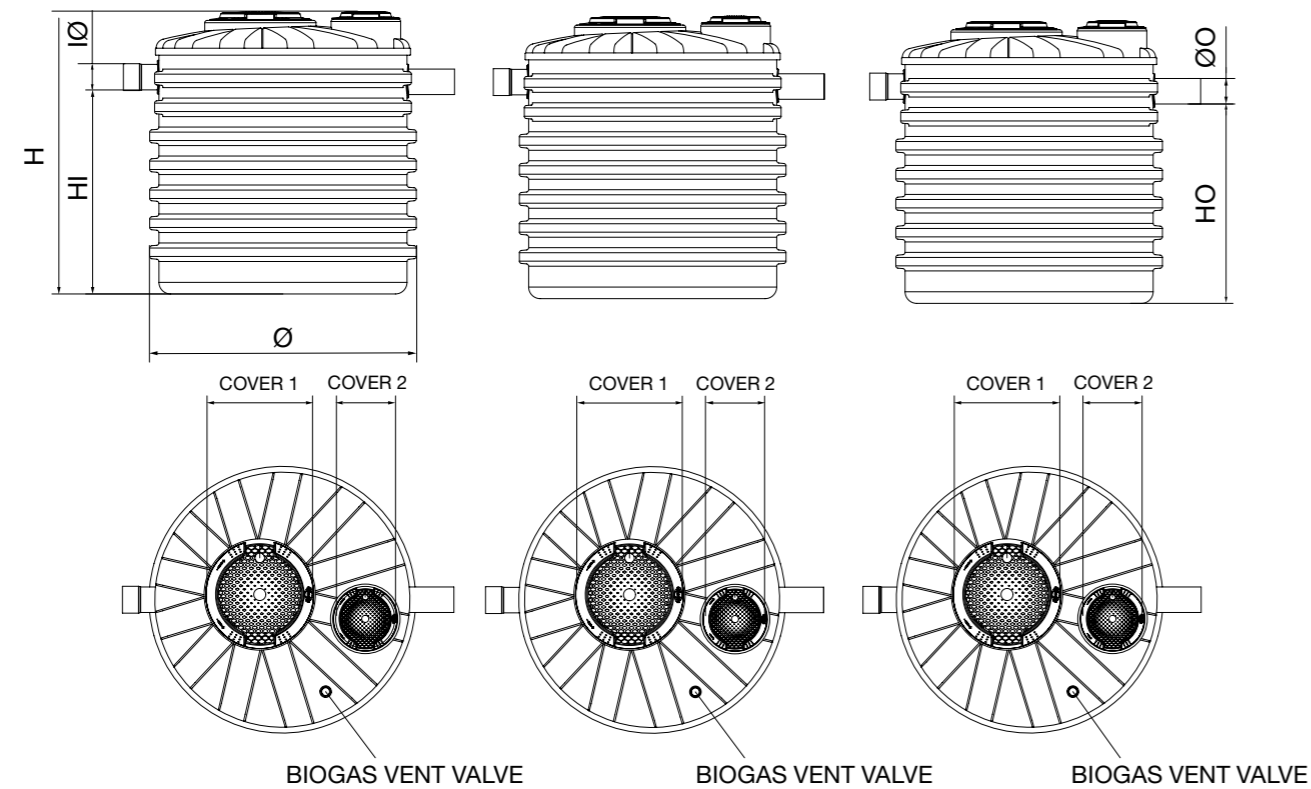

MODULAR THREE-CHAMBER BIOLOGICAL SEPTIC TANKS

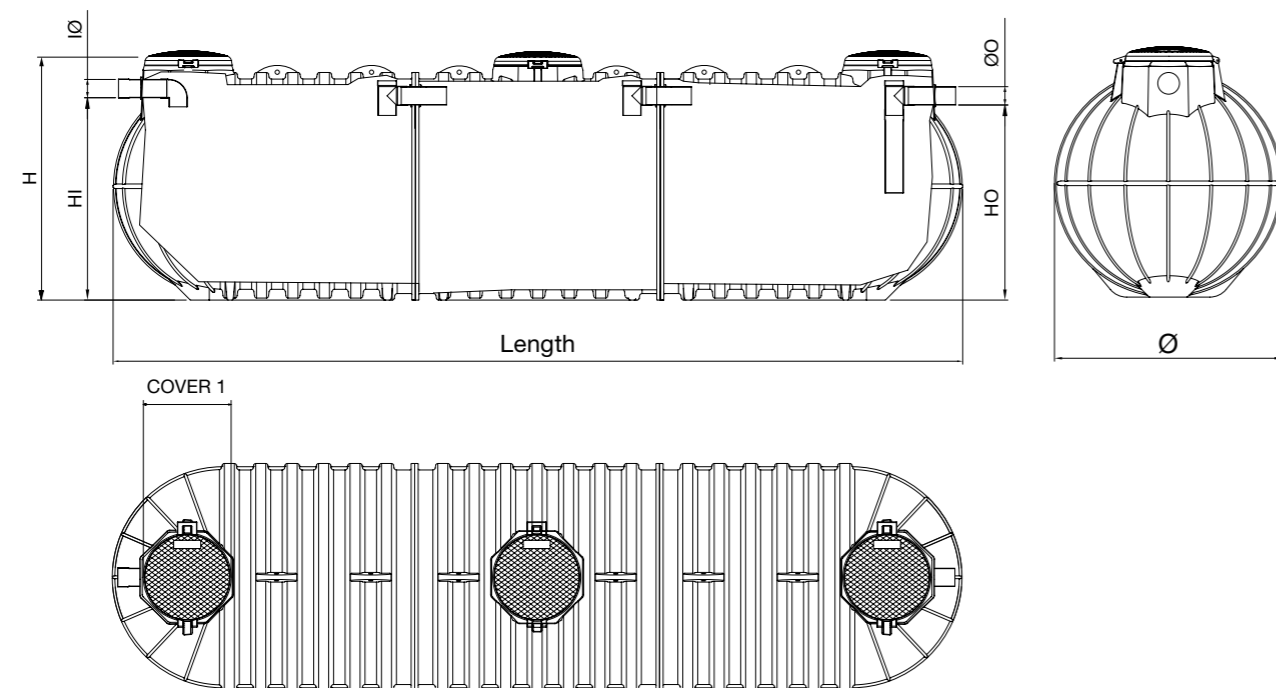

THREE-CHAMBER BIOLOGICAL SEPTIC TANKS

Item	Mod.	Length mm	Width mm	Ø mm	H mm	HI mm	HO mm	Ø I/O mm	Cover 1	Cover 2	Extension 1 (optional)	Extension 2 (optional)	Useful volume l	P.E.
XSET400X3		-	-	790	800	635	615	110	CC400	CC130C	PP45	-	813	6
XSET500X3		-	-	950	900	720	700	110	CC400	CC130C	PP45	-	1389	9
XSET700X3		-	-	1150	923	630	610	110	CC400	CC200	PP45	PP30	1698	12
XSET900X3		-	-	1150	1048	750	730	110	CC400	CC200	PP45	PP30	2100	15
XSET1000X3		-	-	1150	1221	933	913	110	CC400	CC200	PP45	PP30	2664	21
NSET1200X3		1900	708	-	1630	1250	1230	110	CC300	CC300	PP35	PP35	3600	27
XSET1250X3		-	-	1150	1478	1175	1155	110	CC400	CC200	PP45	PP30	3270	27
XSET1500X3		-	-	1150	1779	1465	1445	110	CC400	CC300	PP45	PP35	4152	33
new XSET1750X3		-	-	1350	1672	1285	1265	110	CC400	CC300	PP45	PP35	4935	36
NSET1700X3		1900	708	-	2140	1760	1740	110	CC300	CC300	PP35	PP35	5325	39
NSET2100X3		-	-	1350	1975	1540	1520	110	CC400	CC300	PP45	PP35	5550	45
NSET2600X3		-	-	1710	1450	1000	980	125	CC400	CC300	PP45	PP35	6183	48
NSET3200X3		-	-	1710	1725	1240	1220	125	CC400	CC300	PP45	PP35	7575	60
NSET3800X3		-	-	1710	1955	1525	1505	125	CC400	CC300	PP45	PP35	9525	72
NSET4600X3		-	-	1710	2225	1745	1725	125	CC400	CC300	PP45	PP35	11505	90
NSET5400X3		-	-	1950	2250	1700	1680	125	CC400	CC400	PP45	PP45	13734	108
NSET6400X3		-	-	1950	2530	2000	1980	125	CC400	CC400	PP45	PP45	15879	126
NSET7000X3		-	-	2250	2367	1850	1830	160	CC400	CC400	PP45	PP45	20802	165
NSET9000X3		-	-	2250	2625	2070	2050	160	CC400	CC400	PP45	PP45	23619	210

MODULAR THREE-CHAMBER BIOLOGICAL SEPTIC TANKS

Item	Mod.	Length mm	Ø mm	H mm	HI mm	HO mm	Ø I/O mm	Covers	Extension	Section 1 volume l	Section 2 volume l	Section 3 volume l	Overall useful volume l	P.E.
NTSET3000	nanotank	3420	1150	1320	960	940	125	TAP800	PP77	910	910	910	2730	22
NTSET4000	nanotank	4500	1150	1320	960	940	125	TAP800	PP77	1820	910	910	3640	30
NTSET5000	nanotank	5570	1150	1320	960	940	125	TAP800	PP77	1820	1820	910	4550	40
NTSET6000	nanotank	6650	1150	1320	960	940	125	TAP800	PP77	1820	1820	1820	5460	45
MTSET9000	minitank	5520	1550	1710	1400	1380	160	TAP800	PP77	2900	2900	2900	8700	85
MTSET12000	minitank	7180	1550	1710	1400	1380	160	TAP800	PP77	5800	2900	2900	11600	105
MTSET15000	minitank	8840	1550	1710	1400	1380	160	TAP800	PP77	5800	5800	2900	14500	140
MTSET18000	minitank	10510	1550	1710	1400	1380	160	TAP800	PP77	5800	5800	5800	17400	170
ITSET20000	infinite tank	7270	2100	2200	1850	1830	200	TAP800	PP77	7000	7000	5000	19000	180
ITSET28000	infinite tank	9530	2100	2200	1850	1830	200	TAP800	PP77	12000	7000	5000	24000	230
ITSET30000	infinite tank	10140	2100	2200	1850	1830	200	TAP800	PP77	14000	7000	7000	28000	270
ITSET36000	infinite tank	12400	2100	2200	1850	1830	200	TAP800	PP77	14000	14000	7000	35000	330
ITSET40000	infinite tank	13460	2100	2200	1850	1830	200	TAP800	PP77	12000	14000	12000	38000	370

P.E.= population equivalent; Ø= diameter; H= height; HI= inlet pipe height; HO= outlet pipe height; Ø I/O= inlet/outlet pipe diameter



SEPTIC TANK WITH PRE-FILTER



CE
UNI EN 12566-1

Septic tank with pre-filter for the primary and secondary treatment of domestic sewage or similar wastewater, made of polyethylene (PE) and manufactured by an ISO 9001:2008 certified company.

The tank is designed for underground installation and includes: PVC inlet pipe with watertight gasket and 90° elbow for flow deceleration and distribution, internal basket filter containing high-surface-area black isotactic polypropylene (PP) elements, perforated PVC outlet pipe with watertight gasket, biogas vent valve, and PP cover for inspection, maintenance, and flushing. Optional extensions for the inspection cover.

Item	Mod.	Ø mm	H mm	HI mm	HO mm	Ø I/O mm	Covers	Extension	Useful volume l	P.E.
XSEAN400	Exagon	790	800	635	615	110	CC400-CC130C	PP45	271	1
XSEAN500	Exagon	950	900	720	700	110	CC400-CC130C	PP45	463	2
XSEAN700	Exagon	1150	923	630	610	110	CC400-CC200	PP45-PP30	566	4
XSEAN900	Exagon	1150	1048	750	730	110	CC400-CC200	PP45-PP30	700	5
XSEAN1000	Exagon	1150	1221	933	913	110	CC400-CC200	PP45-PP30	888	7
XSEAN1250	Exagon	1150	1478	1175	1155	110	CC400-CC200	PP45-PP30	1090	9
XSEAN1500	Exagon	1150	1779	1465	1445	110	CC400-CC300	PP45-PP35	1384	11
XSEAN1750	Exagon	1350	1672	1285	1265	110	CC400-CC300	PP45-PP35	1645	12
SEAN2100	Corrugated	1350	1975	1540	1520	110	CC400-CC300	PP45-PP35	1950	15
SEAN2600	Corrugated	1710	1450	1000	980	125	CC400-CC300	PP45-PP35	2061	16
SEAN3200	Corrugated	1710	1725	1240	1220	125	CC400-CC300	PP45-PP35	2525	20
SEAN3800	Corrugated	1710	1955	1525	1505	125	CC400-CC300	PP45-PP35	3175	24
SEAN4600	Corrugated	1710	2225	1745	1725	125	CC400-CC300	PP45-PP35	3835	30
SEAN5400	Corrugated	1950	2225	1700	1680	125	CC400-CC400	PP45-PP45	4578	40
SEAN6400	Corrugated	1950	2530	2000	1980	125	CC400-CC400	PP45-PP45	5293	50
SEAN7000	Corrugated	2250	2367	1850	1830	160	CC400-CC400	PP45-PP45	6934	65
SEAN9000	Corrugated	2250	2625	2070	2050	160	CC400-CC400	PP45-PP45	7823	66-80

P.E.= population equivalent; Ø= diameter; H= height; HI= inlet pipe height; HO= outlet pipe height; Ø I/O= inlet/outlet pipe diameter.

INSTALLATION DIAGRAM

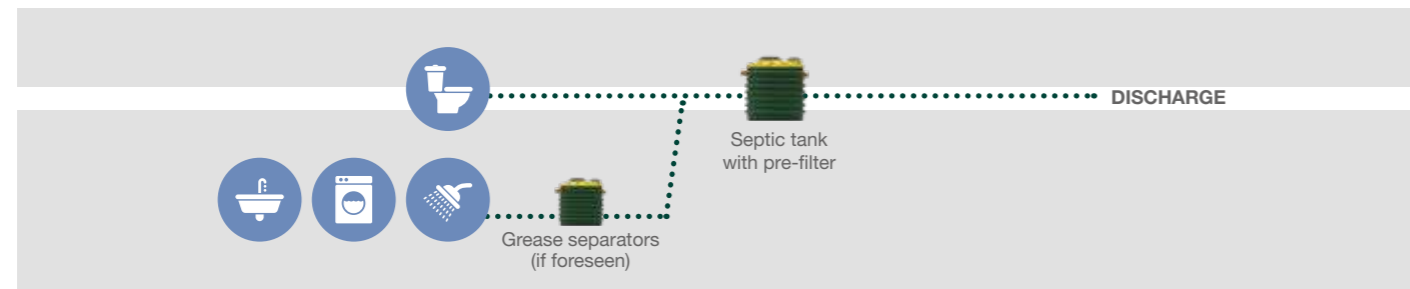

HORIZONTAL SEPTIC TANK WITH PRE-FILTER



CE
UNI EN 12566-1

Septic tank with pre-filter for the primary and secondary treatment of domestic sewage or similar wastewater, made of polyethylene (PE) and manufactured by an ISO 9001:2008 certified company.

The tank is designed for underground installation and includes: PVC inlet pipe with watertight gasket and 90° elbow for flow deceleration and distribution, internal basket filter containing high-surface-area black isotactic polypropylene (PP) elements, perforated PVC outlet pipe with watertight gasket, biogas vent valve, and PP cover for inspection, maintenance, and flushing. Optional extensions for the inspection cover.

Item	Ø mm	Length mm	H mm	HI mm	HO mm	Ø I/O mm	Cover	Extensions	Useful volume l	P.E.
NSEAN2000	1150	2350	1320	960	940	125	TAP800	PP77	2000	12-15
NSEAN3000	1150	3420	1320	960	940	125	TAP800	PP77	3000	16-22
NSEAN4000	1150	4500	1320	960	940	125	TAP800	PP77	4000	23-30
NSEAN5000	1150	5570	1320	960	940	125	TAP800	PP77	5000	31-45
NSEAN6000	1150	6650	1320	960	940	125	TAP800	PP77	6000	46-52
MSEAN6000	1150	3870	1710	1400	1380	125	TAP800	PP77	6000	46-52
MSEAN9000	1150	5520	1710	1400	1380	125	TAP800	PP77	9000	53-85
MSEAN12000	1150	7180	1710	1400	1380	125	TAP800	PP77	12000	86-110

P.E.= population equivalent; Ø= diameter; H= height; HI= inlet pipe height; HO= outlet pipe height; Ø I/O= inlet/outlet pipe diameter.

INSTALLATION DIAGRAM

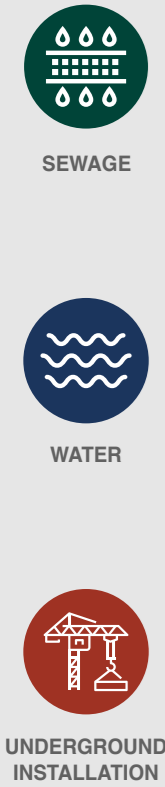
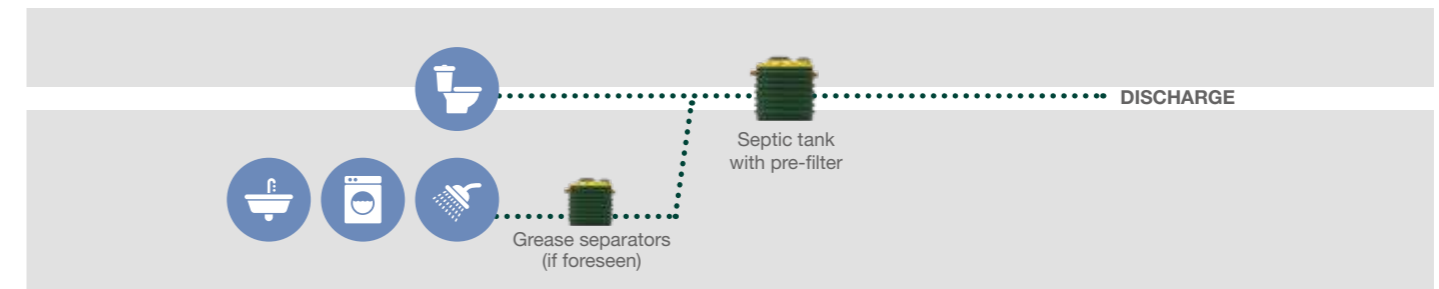

MONOBLOC SEPTIC TANK WITH PRE-FILTER MODEL "EXAGON"

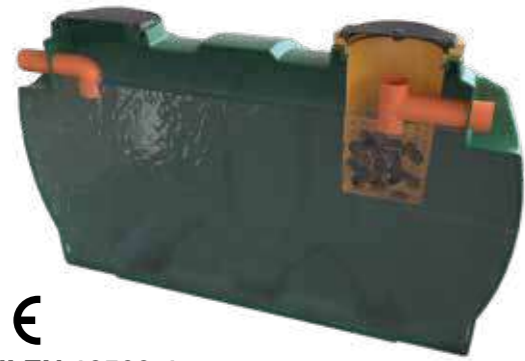

CE
UNI EN 12566-1

Item	Width mm	Length mm	H mm	HI mm	HO mm	Ø I/O mm	Cover	Extensions	Useful volume l	P.E.
XCSE2000PF	1220	2350	1220	1025	1023	110	CC400	PP45	2060	16
XCSE3000PF	1450	2450	1450	1210	1190	110	CC400	PP45	3020	16-22

P.E.= population equivalent; Ø= diameter; H= height; HI= inlet pipe height; HO= outlet pipe height; Ø I/O= inlet/outlet pipe diameter.

INSTALLATION DIAGRAM

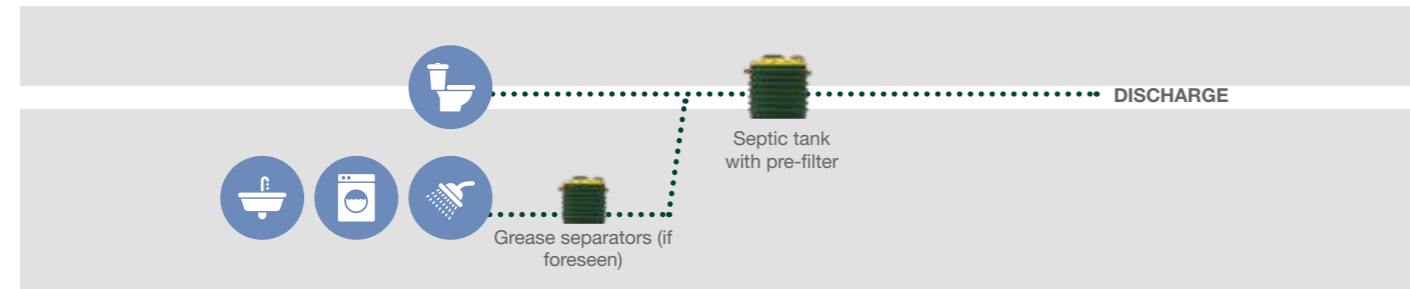

WATERTIGHT SEPTIC TANK



TECHNICAL CHARACTERISTICS

Watertight septic tanks are a reliable method for storing and retaining wastewater without the need for a drainage system. They are passive, stable, simple, and economical treatment systems, primarily used in small communities or areas where a wastewater removal system is not available. Unlike conventional septic tanks, watertight septic tanks do not have an outlet pipe; therefore, the wastewater is stored in a controlled manner until the tank requires emptying.

The tank's internal structure forces the wastewater to pass through the contained fluid mass, promoting sedimentation of heavier solids and separation of substances with a specific gravity lower than that of water. An anaerobic fermentation process is also initiated, contributing to the solubilization and transformation of some suspended solids into dissolved and colloidal liquids. This allows for further treatment of the stored wastewater within the watertight tank, even though the system does not allow for continuous discharge.

Once stored, the effluent must be managed in compliance with local regulations regarding disposal or subsequent treatment.

USE

Storage and primary treatment of sewage from toilets, without direct discharge, requiring the tank to be emptied upon reaching capacity.

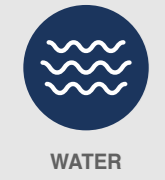
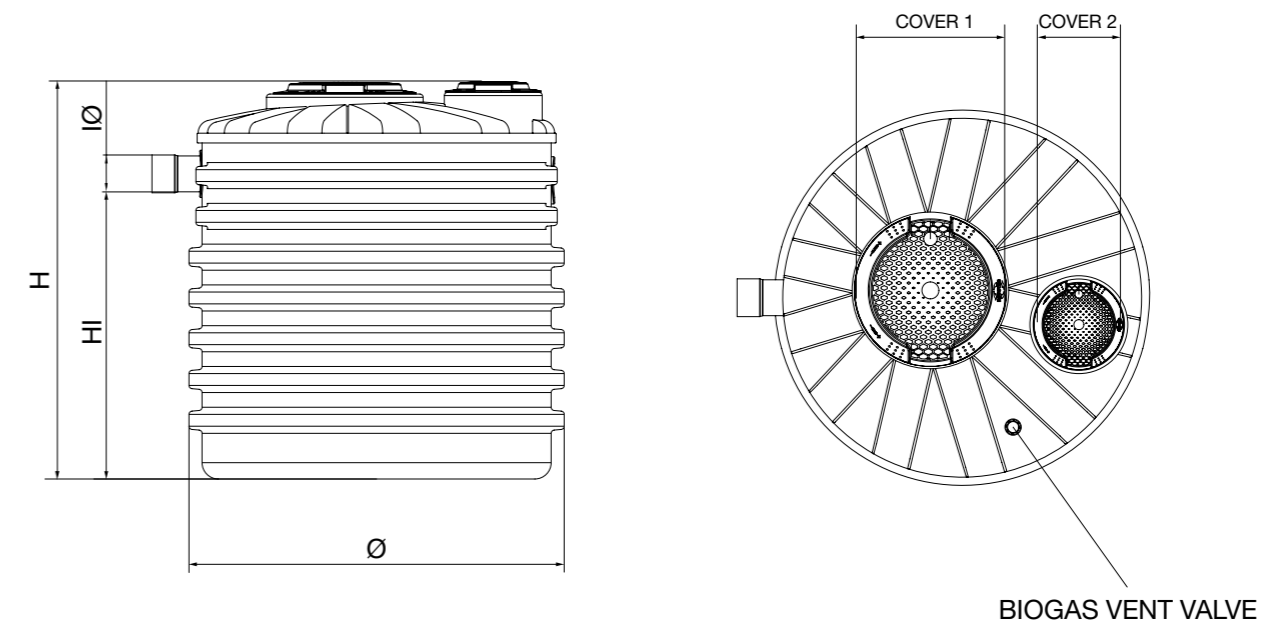



SEWAGE



WATER



UNDERGROUND INSTALLATION



Item	Mod.	Length mm	Width mm	Ø mm	H mm	I Ø mm	Cover 1	Cover 2	Extension 1 (optional)	Extension 2 (optional)	Useful volume l	P.E.
SE500ES		-	-	790	790	110	CC400	CC130	PP45	-	305	2
XSE700ES		-	-	1150	923	110	CC400	CC130C	PP45	-	463	3
XSE1000ES		-	-	1150	1048	110	CC400	CC200	PP45	PP30	888	7
NSE1200ES		1900	708	-	1630	110	CC300	CC300	PP35	PP35	1200	9
XSE1250ES		-	-	1150	1478	110	CC400	CC200	PP45	PP30	1090	9
XSE1500ES		-	-	1150	1779	110	CC400	CC300	PP45	PP35	1384	11
new XSE1750ES		-	-	1350	1672	110	CC400	CC300	PP45	PP35	1645	12
NSE1700ES		1900	708	-	2140	110	CC300	CC300	PP3	PP35	1775	13
NSE2100ES		-	-	1350	1975	110	CC400	CC300	PP45	PP35	1950	15
NSE2600ES		-	-	1710	1450	125	CC400	CC300	PP45	PP35	2061	16
NSE3200ES		-	-	1710	1725	125	CC400	CC300	PP45	PP35	2525	20
NSE3800ES		-	-	1710	1955	125	CC400	CC300	PP45	PP35	3175	24
NSE4600ES		-	-	1710	2225	125	CC400	CC300	PP45	PP35	3835	30
NSE5400ES		-	-	1950	2250	125	CC400	CC300	PP45	PP45	4578	36
NSE6400ES		-	-	1950	2530	125	CC400	CC300	PP45	PP45	5293	42
NSE7000ES		-	-	2250	2367	160	CC400	CC400	PP45	PP45	6934	55
NSE9000ES		-	-	2250	2625	160	CC400	CC400	PP45	PP45	7823	70
NSE10700ES		2780	2430	-	2625	160	TAP800	.	PP77	-	10100	100
ITSE11000ES		4420	-	2100	2200	160	TAP800	-	PP77	-	10135	100
ITSE13000ES		5010	-	2100	2200	160	TAP800	-	PP77	-	12105	120
ITSE15000ES		5620	-	2100	2200	160	TAP800	-	PP77	-	14150	140
ITSE18000ES		6680	-	2100	2200	160	TAP800	-	PP77	-	16900	165
ITSE20000ES		7270	-	2100	2200	200	TAP800	-	PP77	-	18610	185
ITSE22000ES		7880	-	2100	2200	200	TAP800	-	PP77	-	20700	200
ITSE25000ES		8940	-	2100	2200	200	TAP800	-	PP77	-	22800	225
ITSE28000ES		9530	-	2100	2200	200	TAP800	-	PP77	-	25200	250
ITSE30000ES		10140	-	2100	2200	250	TAP800	-	PP77	-	27250	270
ITSE33000ES		11200	-	2100	2200	250	TAP800	-	PP77	-	29540	290
ITSE35000ES		11790	-	2100	2200	250	TAP800	-	PP77	-	31710	310
ITSE36000ES		12400	-	2100	2200	250	TAP800	-	PP77	-	33800	330
ITSE40000ES		13460	-	2100	2200	250	TAP800	-	PP77	-	36180	360

P.E.= population equivalent; Ø= diameter; H= height; I Ø= inlet/outlet pipe diameter.

NOTES

ACTIVATED SLUDGE

FIND OUT MORE



LOW-LOAD ACTIVATED SLUDGE PLANTS



SEWAGE



WATER



UNDERGROUND INSTALLATION

1 OXYGENATION AREA

Area in which the effluent is mixed and oxygenated, thanks to micro-bubble air diffuser plates, powered by an external blower/compressor. This develops aerobic bacteria that transform the biodegradable compounds into CO₂, organic nitrogen into ammonia and ammonia into nitrates.

2 SEDIMENTATION AREA

Stilling area in which the residual sludge sediments and returns once again to the oxygenation section.

3 FINAL DISINFECTION

Housing, on the outlet pipe, into which a slow release chlorine tablet is inserted (tablet not included). In this way the effluent is disinfected before being discharged (when required).

4 BLOWER

Included in the supply.

5 DIFFUSER PLATE

Included in the supply.



CE
UNI 12566-3

SPECIFICATIONS

CHARACTERISTICS

Activated sludge plants are secondary treatment systems that make use of the action of the bacterial colonies that, remaining in suspension in the sewage, consume the biodegradable organic material, using it as a nutrient to obtain the necessary energy and the material required for the synthesis of new cells. In this manner, increasingly stable compounds are formed leading to the total degradation of the organic load. Very high concentrations of aerobic type bacteria are developed inside activated sludge plants, sufficient, that is, to absorb the dissolved oxygen in the water in order to consume the biodegradable material. To guarantee the concentration of oxygen necessary for the development of the biological reaction, an aeration system is adopted consisting of submerged diffusers which, from the bottom of the tank, disperse a flow of fine air bubbles. This also guarantees sufficient mixing to keep the high concentrations of solids present in the tank in suspension.

USE

Secondary treatment of domestic sewage

REFERENCE STANDARDS

UNI EN 12566-3.

SEWAGE TREATMENT EFFICIENCY

The wastewater treatment system made up of a grease separator, an Imhoff biological tank and an activated sludge plant (installed as shown in the diagram at page 52) ensures that the concentrations of the final effluent are:

≤160 mg/l
COD

≤40 mg/l
BOD₅

≤80 mg/l
SS

These parameters are respected if the inlet wastewater have the following characteristics (typical concentrations of domestic sewage):

≤600 mg/l
COD

≤300 mg/l
BOD₅

≤400 mg/l
SS

INSTALLATION DIAGRAM

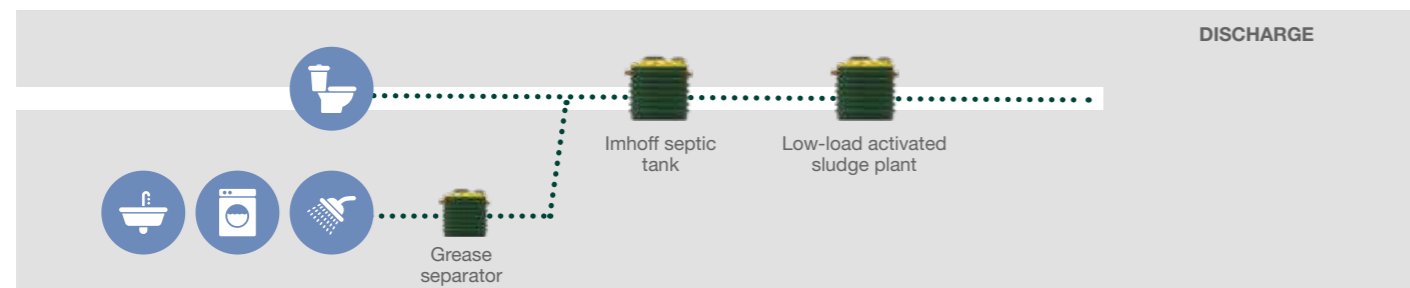

TOTAL OXIDATION ACTIVATED SLUDGE PLANTS

[FIND OUT MORE](#)

1 OXYGENATION AREA

Area in which the effluent is mixed and oxygenated, thanks to micro-bubble air diffuser plates, powered by an external blower/compressor. This develops aerobic bacteria that transform the biodegradable compounds into CO₂, organic nitrogen into ammonia and ammonia into nitrates.

2 FINAL DISINFECTION

Housing, on the outlet pipe, into which a slow release chlorine tablet is inserted (tablet not included). In this way the effluent is disinfected before being discharged (when required).

3 BLOWER

Included in the supply.

4 DIFFUSER PLATE

Included in the supply.



CE
UNI 12566-3

CHARACTERISTICS

Total oxidation activated sludge plants are primary (degreased) domestic sewage treatment systems that make use of the action of the bacterial colonies that, remaining in suspension in the effluent, consume the biodegradable organic material, using it as a nutrient to obtain the necessary energy and the material required for the synthesis of new cells. In this manner, increasingly stable compounds are formed leading to the total degradation of the organic load. Very high concentrations of aerobic type bacteria are developed inside activated sludge plants, sufficient, that is, to absorb the dissolved oxygen in the water in order to consume the biodegradable material. To guarantee the concentration of oxygen necessary for the development of the biological reaction, an aeration system is adopted consisting of submerged diffusers which, from the bottom of the tank, disperse a flow of fine air bubbles. This also guarantees sufficient mixing to keep the high concentrations of solids present in the tank in suspension.

USE

Primary treatment of degreased domestic sewage.

REFERENCE STANDARDS

UNI 12566-3.

SEWAGE TREATMENT EFFICIENCY

The wastewater treatment system made up of a grease separator and a total oxidation activated sludge plant (installed as shown in the diagram at page 56) ensures that the concentrations of the final effluent are:

≤160 mg/l
COD

≤40 mg/l
BOD₅

≤80 mg/l
SS

These parameters are respected if the inlet wastewater have the following characteristics (typical concentrations of domestic sewage):

≤600 mg/l
COD

≤300 mg/l
BOD₅

≤400 mg/l
SS

INSTALLATION DIAGRAM

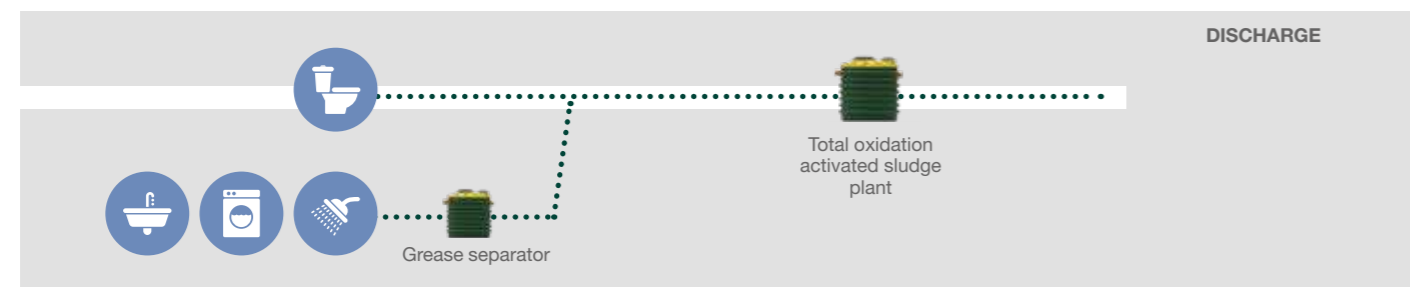

TOTAL OXIDATION ACTIVATED SLUDGE PLANTS

Item	Mod.	Length mm	Width mm	Ø mm	H mm	HI mm	HO mm	Ø I/O mm	Cover 1	Cover 2	Extension 1 (optional)	Extension 2 (optional)	Aerated Vol. l	Blower Mod.	Diffuser plates No.	P.E.
XIFAT700		-	-	1150	923	630	610	110	CC400	CC200	PP45	PP30	566	HP40	1	1
XIFAT1000		-	-	1150	1221	933	913	110	CC400	CC200	PP45	PP30	888	HP40	1	2
XIFAT1250		-	-	1150	1478	1175	1155	110	CC400	CC200	PP45	PP30	1090	HP40	1	3
XIFAT1500		-	-	1150	1779	1465	1445	110	CC400	CC300	PP45	PP35	1384	HP40	1	4
NIFAT2100		-	-	1350	1975	1540	1520	110	CC400	CC300	PP45	PP35	1950	HP60	2	5
NIFAT2600		-	-	1710	1450	1000	980	125	CC400	CC300	PP45	PP35	2061	HP80	2	6
NIFAT3200		-	-	1710	1725	1240	1220	125	CC400	CC300	PP45	PP35	2525	HP80	2	8
NIFAT3800		-	-	1710	1955	1490	1470	125	CC400	CC300	PP45	PP35	3104	HP80	2	10
NIFAT4600		-	-	1710	2225	1710	1690	125	CC400	CC300	PP45	PP35	3594	HP80	2	12
NIFAT5400		-	-	1950	2250	1660	1640	125	CC400	CC400	PP45	PP45	4578	HP80	2	15
NIFAT6400		-	-	1950	2530	1970	1950	125	CC400	CC400	PP45	PP45	5293	HP80	2	20
NIFAT7000		-	-	2250	2367	1850	1830	125	CC400	CC400	PP45	PP45	6934	HP150	2	25
NIFAT9000		-	-	2250	2625	2070	2050	125	CC400	CC400	PP45	PP45	7823	HP150	2	30
ITIFAT11000		4420	-	2100	2200	1870	1850	160	TAP800	-	PP77	-	10135	HP302SF	8	36
ITIFAT13000		5010	-	2100	2200	1870	1850	160	TAP800	-	PP77	-	12105	HP402SF	10	44
ITIFAT15000		5620	-	2100	2200	1870	1850	160	TAP800	-	PP77	-	14150	HP402SF	12	50
ITIFAT18000		6680	-	2100	2200	1870	1850	160	TAP800	-	PP77	-	16962	HP402SF	14	60
ITIFAT20000		7270	-	2100	2200	1870	1850	160	TAP800	-	PP77	-	18610	HP402SF	16	68
ITIFAT22000		7880	-	2100	2200	1870	1850	160	TAP800	-	PP77	-	20700	HP402SF	18	75
ITIFAT25000		8940	-	2100	2200	1870	1850	160	TAP800	-	PP77	-	22985	HP402SF	20	85
ITIFAT28000		9530	-	2100	2200	1870	1850	160	TAP800	-	PP77	-	25270	HP402SF	22	92
ITIFAT30000		10140	-	2100	2200	1870	1850	160	TAP800	-	PP77	-	27250	HP502SF	24	100
ITIFAT33000		11200	-	2100	2200	1870	1850	160	TAP800	-	PP77	-	29630	HP502SF	26	110
ITIFAT35000		11790	-	2100	2200	1870	1850	160	TAP800	-	PP77	-	31710	HP502SF	28	120
ITIFAT36000		12400	-	2100	2200	1870	1850	160	TAP800	-	PP77	-	33800	HP502SF	30	130
ITIFAT40000		13460	-	2100	2200	1870	1850	160	TAP800	-	PP77	-	36290	HP502SF	32	140

P.E.= population equivalent; Ø= diameter; H= height; HI= inlet pipe height; HO= outlet pipe height; Ø I/O= inlet/outlet pipe diameter.

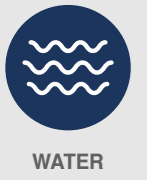

TRICKLE FILTERS

FIND OUT MORE

ANAEROBIC TRICKLE FILTER



SEWAGE



WATER



UNDERGROUND INSTALLATION

- 1 DISTRIBUTION PIPE**
Perforated pipe for even distribution of the effluent onto the surface of the filter.
- 2 FILTER MEDIA**
Plastic bulk fill material with a large surface area that acts as a support on which the anaerobic bacteria responsible for treating the effluent can develop.
- 3 COLLECTION PIPE**
Pipe to draw off the treated effluent from the bottom and send it to the outlet.



CE
UNI 12566-3

SPECIFICATIONS

TECHNICAL CHARACTERISTICS

A trickle filter is a biological reactor, inside which the micro-organisms that purify the effluent develop on the surface of special bulk fill material (filter media). The uniform distribution of the effluent through the filter guarantees maximum contact between the organic material to purify and the biological film covering the spheres making up the fill material. More specifically, the bacteria that grow and develop inside the anaerobic trickle filter consume the organic load in the effluent in the absence of dissolved oxygen.

USE

Secondary treatment of domestic sewage.

REFERENCE STANDARDS

UNI 12566-3.

SEWAGE TREATMENT EFFICIENCY

The wastewater treatment system made up of a grease separator, an Imhoff biological tank and an anaerobic trickle filter (installed as shown in the diagram at page 58) ensures that the concentrations of the final effluent are:

≤160 mg/l COD ≤40 mg/l BOD₅ ≤80 mg/l SS

These parameters are respected if the inlet wastewater have the following characteristics (typical concentrations of domestic sewage):

≤600 mg/l COD ≤300 mg/l BOD₅ ≤400 mg/l SS

INSTALLATION DIAGRAM

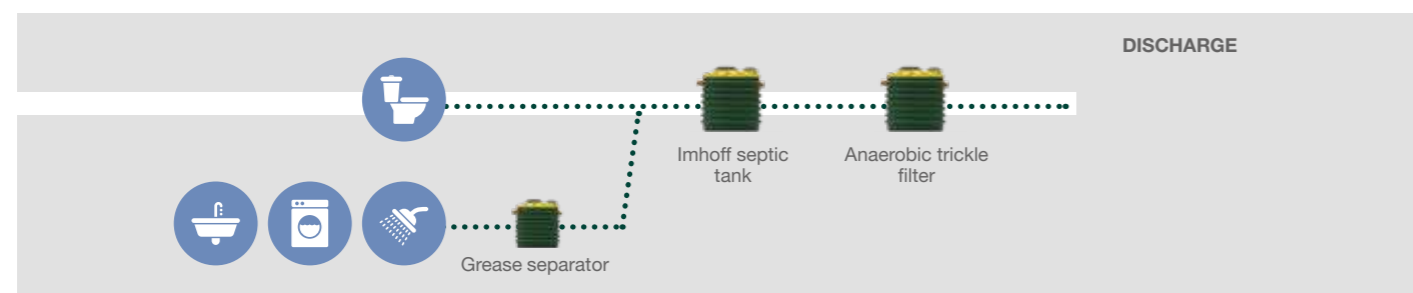

ANAEROBIC TRICKLE FILTERS

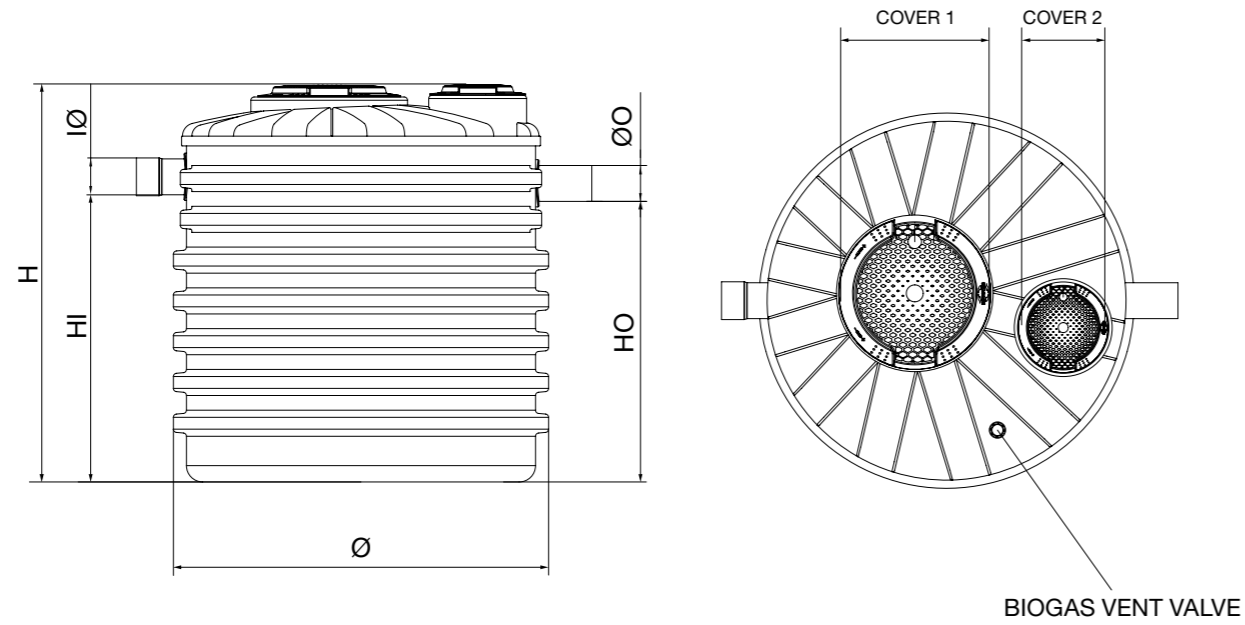

MODULAR ANAEROBIC TRICKLE FILTERS

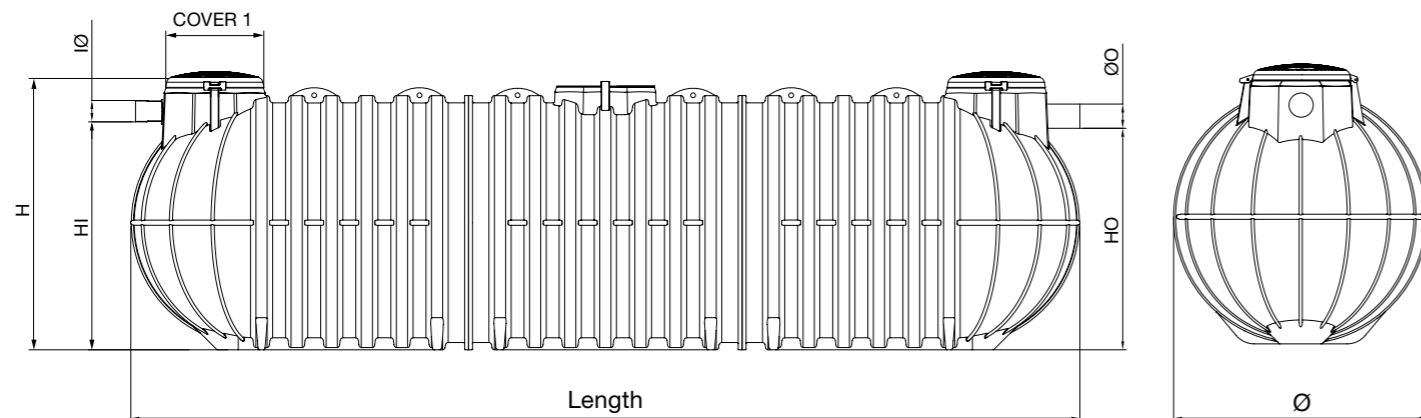

ANAEROBIC TRICKLE FILTER

Item	Mod.	Length mm	Width mm	Ø mm	H mm	HI mm	HO mm	Ø I/O mm	Cover 1	Cover 2	Extension 1 (optional)	Extension 2 (optional)	Filter Surface m ²	Filter Volume m ³	P.E.
XAN400		-	-	790	800	635	615	110	CC400	CC130C	PP45	-	0.48	0.25	1
XAN500		-	-	950	900	720	700	110	CC400	CC130C	PP45	-	0.7	0.42	2
XAN700		-	-	1150	923	630	610	110	CC400	CC200	PP45	PP30	1.03	0.53	3
XAN900		-	-	1150	1048	750	730	110	CC400	CC200	PP45	PP30	1.3	0.65	5
XAN1000		-	-	1150	1221	933	913	110	CC400	CC200	PP45	PP30	1.03	0.84	6
NAN1200		1900	708	/	1630	1250	1230	110	CC300	CC300	PP35	PP35	1.35	1.2	7
XAN1250		-	-	1150	1478	1175	1155	110	CC400	CC200	PP45	PP30	1.3	1.09	7
XAN1500		-	-	1150	1779	1465	1445	110	CC400	CC300	PP45	PP35	1.3	1.39	9
NAN1700		1900	708	/	2140	1760	1740	110	CC300	CC300	PP35	PP35	1.35	1.77	10
new XAN1750		-	-	1350	1672	1285	1265	110	CC400	CC300	PP45	PP35	1.43	1.67	11
NAN2600		-	-	1710	1450	1000	980	125	CC400	CC300	PP45	PP35	2.3	2.06	14
NAN3200		-	-	1710	1725	1240	1220	125	CC400	CC300	PP45	PP35	2.3	2.52	20
NAN3800		-	-	1710	1955	1490	1470	125	CC400	CC300	PP45	PP35	2.3	3.1	23
NAN4600		-	-	1710	2225	1710	1690	160	CC400	CC300	PP45	PP35	2.3	3.8	27
NAN5400		-	-	1950	2250	1660	1640	160	CC400	CC400	PP45	PP45	2.9	4.75	32
NAN6400		-	-	1950	2530	1970	1950	160	CC400	CC400	PP45	PP45	2.9	5.07	36
NAN7000		-	-	2250	2367	1850	1830	160	CC400	CC400	PP45	PP45	3.98	6.93	45
NAN9000		-	-	2250	2625	2070	2050	160	CC400	CC400	PP45	PP45	3.98	7.82	55
ITAN11000		4420	-	2100	2200	1830	1800	160	TAP800	/	PP77	-	8.1	10.13	70
NAN10700		2780	2430	/	2660	2170	2130	160	TAP800	/	PP77	-	6.75	10	75
ITAN13000		5010	-	2100	2200	1830	1800	160	TAP800	/	PP77	-	9.2	12.1	85
ITAN15000		5620	-	2100	2200	1830	1800	160	TAP800	/	PP77	-	10.2	14.15	100
ITAN18000		6680	-	2100	2200	1830	1800	160	TAP800	/	PP77	-	12.4	16.96	120
ITAN20000		7270	-	2100	2200	1830	1800	160	TAP800	/	PP77	-	13.6	18.61	130
ITAN22000		7880	-	2100	2200	1830	1800	160	TAP800	/	PP77	-	14.9	20.07	140
ITAN25000		8940	-	2100	2200	1830	1800	160	TAP800	/	PP77	-	16.8	22.98	160
ITAN28000		9530	-	2100	2200	1810	1780	200	TAP800	/	PP77	-	18	25.27	180
ITAN30000		10140	-	2100	2200	1810	1780	200	TAP800	/	PP77	-	19.16	27.25	200
ITAN33000		11200	-	2100	2200	1810	1780	200	TAP800	/	PP77	-	21.2	29.53	215
ITAN35000		11790	-	2100	2200	1810	1780	200	TAP800	/	PP77	-	22.4	34.71	230
ITAN36000		12400	-	2100	2200	1810	1780	200	TAP800	/	PP77	-	23.67	33.08	240
ITAN40000		13460	-	2100	2200	1810	1780	200	TAP800	/	PP77	-	25.6	36.29	260

P.E.= population equivalent; Ø= diameter; H= height; HI= inlet pipe height; HO= outlet pipe height; Ø I/O= inlet/outlet pipe diameter.

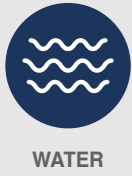

AEROBIC TRICKLE FILTER

FIND OUT MORE

- 1 DISTRIBUTION PIPE**
Perforated pipe for even distribution of the effluent onto the surface of the filter.
- 2 FILTER MEDIA**
Plastic bulk fill material with a large surface area that acts as a support on which the anaerobic bacteria responsible for treating the effluent can develop.
- 3 COLLECTION PIPE**
Pipe to draw off the treated effluent from the bottom and send it to the outlet.
- 4 VENT STACK**
Piping to be routed outdoors to allow oxygenation of the filter media.



CE
UNI EN 12566-3

SPECIFICATIONS

TECHNICAL CHARACTERISTICS

A trickle filter is a biological reactor, inside which the micro-organisms that purify the effluent develop on the surface of special bulk fill material (filter media). The uniform distribution of the effluent through the filter guarantees maximum contact between the organic material to purify and the biological film covering the spheres making up the fill material. Specifically, the microbial flora that colonizes and develops within the aerobic percolating filter metabolizes the organic load contained in the wastewater in the presence of oxygen, which is continuously supplied into the tank via the aeration pipeline.

USE

Secondary treatment of domestic sewage.

REFERENCE STANDARDS

UNI 12566-3.

SEWAGE TREATMENT EFFICIENCY

The wastewater treatment system made up of a grease separator, an Imhoff biological tank and an aerobic trickle filter with top outlet MBBR (installed as shown in the diagram at page 62) ensures that the concentrations of the final effluent are:

≤160 mg/l
COD

≤40 mg/l
BOD₅

≤80 mg/l
SS

These parameters are respected if the inlet wastewater have the following characteristics (typical concentrations of domestic sewage):

≤600 mg/l
COD

≤300 mg/l
BOD₅

≤400 mg/l
SS

INSTALLATION DIAGRAM

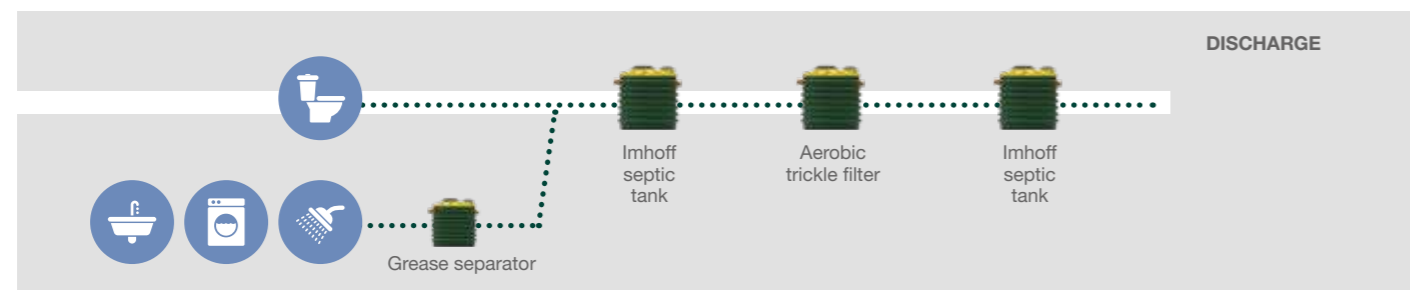

AEROBIC TRICKLE FILTERS

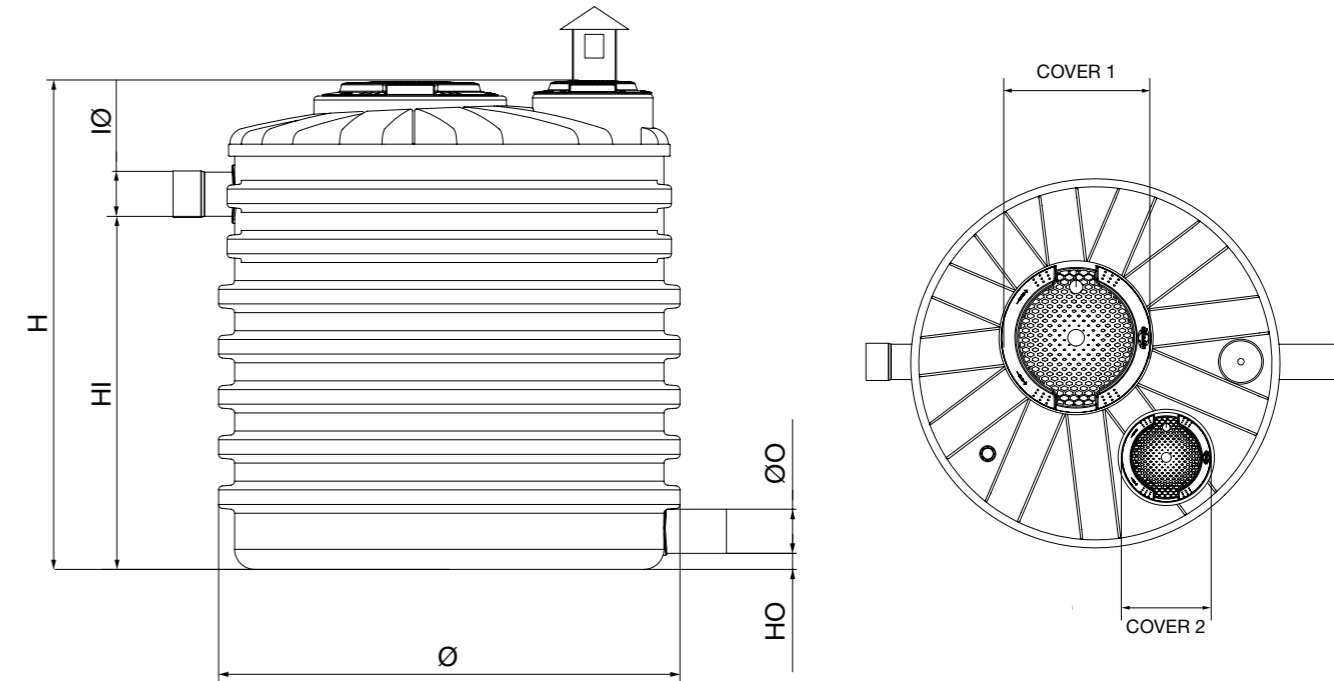

MODULAR AEROBIC TRICKLE FILTERS

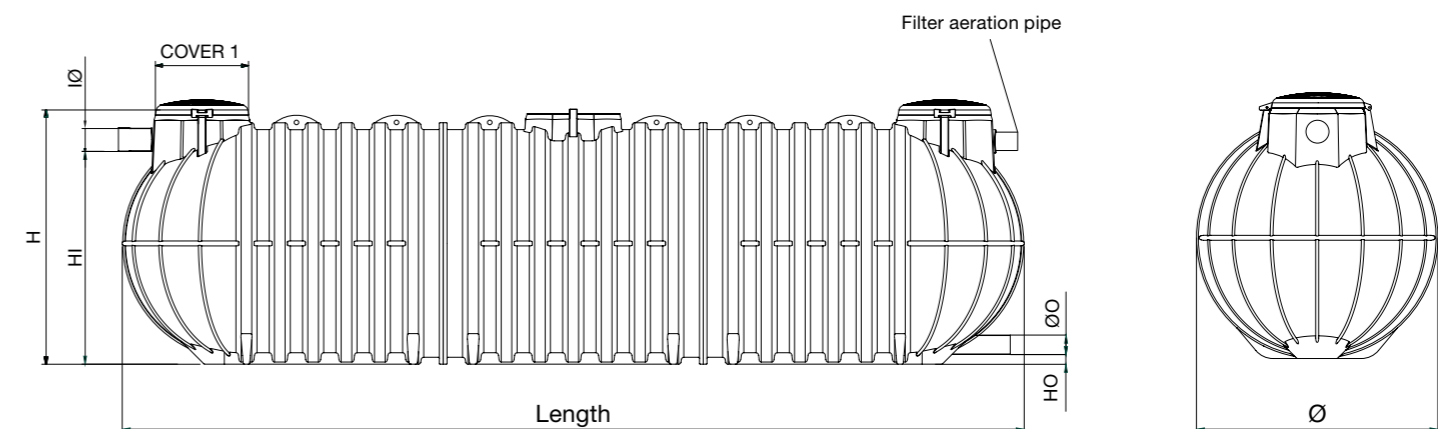

SEWAGE



WATER



UNDERGROUND INSTALLATION



AEROBIC TRICKLE FILTER

Item	Mod.	Length mm	Width mm	Ø mm	H mm	HI mm	HO mm	Ø I/O mm	Cover 1	Cover 2	Extension 1 (optional)	Extension 2 (optional)	Filter Surface m ²	Filter Volume m ³	P.E.
XAR500		-	-	950	900	720	40	110	CC400	CC130C	PP45	-	0.7	0.43	2
XAR700		-	-	1150	923	630	40	110	CC400	CC200	PP45	PP30	1.03	0.54	3
XAR900		-	-	1150	1048	750	40	110	CC400	CC200	PP45	PP30	1.03	0.66	5
XAR1000		-	-	1150	1221	933	40	110	CC400	CC200	PP45	PP30	1.03	0.85	6
XAR1250		-	-	1150	1478	1175	40	110	CC400	CC200	PP45	PP30	1.03	1.10	8
XAR1500		-	-	1150	1779	1465	40	110	CC400	CC300	PP45	PP35	1.03	1.40	9
new XAR1750		-	-	1350	1672	1285	40	110	CC400	CC300	PP45	PP35	1.43	1.68	11
NAR2600		-	-	1710	1450	1000	40	125	CC400	CC300	PP45	PP35	2.30	2.06	14
NAR3200		-	-	1710	1725	1240	40	125	CC400	CC300	PP45	PP35	2.30	2.52	20
NAR3800		-	-	1710	1955	1490	40	125	CC400	CC300	PP45	PP35	2.30	3.10	23
NAR4600		-	-	1710	2225	1710	40	125	CC400	CC300	PP45	PP35	2.30	3.80	27
NAR5400		-	-	1950	2250	1660	40	125	CC400	CC400	PP45	PP45	2.90	4.75	32
NAR6400		-	-	1950	2530	1970	40	125	CC400	CC400	PP45	PP45	2.90	5.07	36
NAR7000		-	-	2250	2367	1850	40	125	CC400	CC400	PP45	PP45	3.98	6.93	45
NAR9000		-	-	2250	2625	2070	40	125	CC400	CC400	PP45	PP45	3.98	7.82	55
NAR10700		2780	2430	-	2660	2170	40	160	TAP800	-	PP77	-	6.75	10.00	75
ITAR11000		4420	-	2100	2200	1830	130	160	TAP800	-	PP77	-	8.10	10.13	70
ITAR13000		5010	-	2100	2200	1830	130	160	TAP800	-	PP77	-	9.20	12.10	85
ITAR15000		5620	-	2100	2200	1830	130	160	TAP800	-	PP77	-	10.20	14.15	100
ITAR18000		6680	-	2100	2200	1830	130	160	TAP800	-	PP77	-	12.40	16.96	120
ITAR20000		7270	-	2100	2200	1830	130	160	TAP800	-	PP77	-	13.60	18.61	130
ITAR22000		7880	-	2100	2200	1830	130	160	TAP800	-	PP77	-	14.90	20.07	140
ITAR25000		8940	-	2100	2200	1830	130	160	TAP800	-	PP77	-	16.80	22.98	160
ITAR28000		9530	-	2100	2200	1810	130	200	TAP800	-	PP77	-	18.00	25.27	180
ITAR30000		10140	-	2100	2200	1810	130	200	TAP800	-	PP77	-	19.16	27.25	200
ITAR33000		11200	-	2100	2200	1810	130	200	TAP800	-	PP77	-	21.20	29.63	215
ITAR35000		11790	-	2100	2200	1810	130	200	TAP800	-	PP77	-	22.40	31.71	230
ITAR36000		12400	-	2100	2200	1810	130	200	TAP800	-	PP77	-	23.67	33.08	240
ITAR40000		13460	-	2100	2200	1810	130	200	TAP800	-	PP77	-	25.60	36.29	260

LIFT STATION TO PUMP WATER LEAVING THE AEROBIC TRICKLE FILTER

SPECIFICATIONS

TECHNICAL CHARACTERISTICS

Narrow vertical cylinder tank for underground installation, in high-density polyethylene (HDPE) fitted with PVC inlet pipe (Ø 125 mm) with N.B.R. rubber seal, submerged electric pump with vortex impeller for sewage connected to a delivery pipe in polyethylene (Ø 50 mm).

The pump is fitted with an automatic start/stop float switch.

USE

To pump the treated waste water leaving aerobic trickle filters. Essential to bring the discharge line up to ground level, in the absence of an adequate difference in level.

Item	Ø mm	H mm	HI* mm	OH mm	IØ / OØ mm	Inspection cover mm	Installed pump	HP	kW	V	H	µF	Head m	Flow rate l/min.
NSOLMG2300	500	2300	2100	125-50	400	Energy1	0.4	0.3	230	2.2	8	6-1	10-140	
NSOLMG2700	500	2700	-	2500	125-50	400	Energy1	0.4	0.3	230	2.2	8	6-1	10-140
NSOLMG3000	500	3000	-	2800	125-50	400	Energy1	0.4	0.3	230	2.2	8	6-1	10-140

[*] To be agreed when ordering

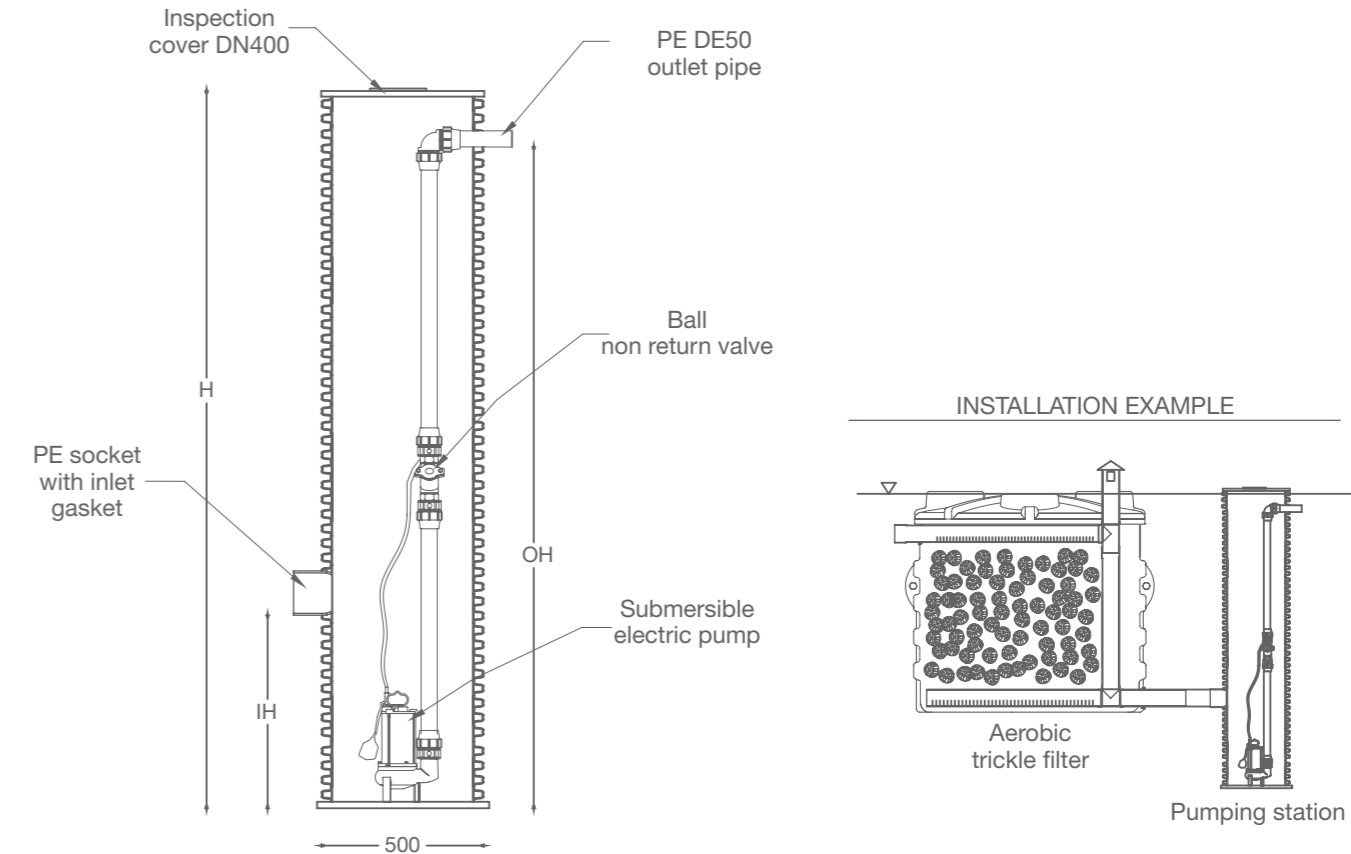

AEROBIC TRICKLE FILTER TOP OUTLET WITH BLOWER (MBBR)

[FIND OUT MORE](#)

- 1 DISTRIBUTION PIPE**
Perforated pipe for even distribution of the effluent onto the surface of the filter.
- 2 FILTER MEDIA**
Plastic bulk fill material with a large surface area that acts as a support on which the aerobic bacteria responsible for treating the effluent can develop.
- 3 COLLECTION PIPE**
Pipe to draw off the treated effluent from the bottom and send it to the outlet.
- 4 COMPRESSOR BLOWER**
To pump the air inside the tank (included).
- 5 DIFFUSER PLATES**
For distribution of the air micro-bubbles (included).



SPECIFICATIONS

TECHNICAL CHARACTERISTICS

A trickle filter is a biological reactor, inside which the micro-organisms that purify the effluent develop on the surface of special bulk fill material (filter media). The uniform distribution of the effluent through the filter guarantees maximum contact between the organic material to purify and the biological film covering the spheres making up the filter material. More specifically, the bacteria that grows and develops inside the aerobic trickle filter with top outlet consumes the organic load in the effluent in the presence of oxygen, continually entering the tank through the external compressor and distributed by the diffuser plates.

USE

Secondary treatment of domestic sewage.

REFERENCE STANDARDS

UNI 12566-3

SEWAGE TREATMENT EFFICIENCY

The wastewater treatment systems made up of a grease separator, an Imhoff biological tank and an aerobic trickle filter treatment (installed as shown in the diagram at page 66) ensures that the concentrations of the final effluent are:

≤100 mg/l
COD

≤20 mg/l
BOD₅

≤25 mg/l
SS

These parameters are respected if the inlet wastewater have the following characteristics (typical concentrations of domestic sewage):

≤600 mg/l
COD

≤300 mg/l
BOD₅

≤400 mg/l
SS

INSTALLATION DIAGRAM

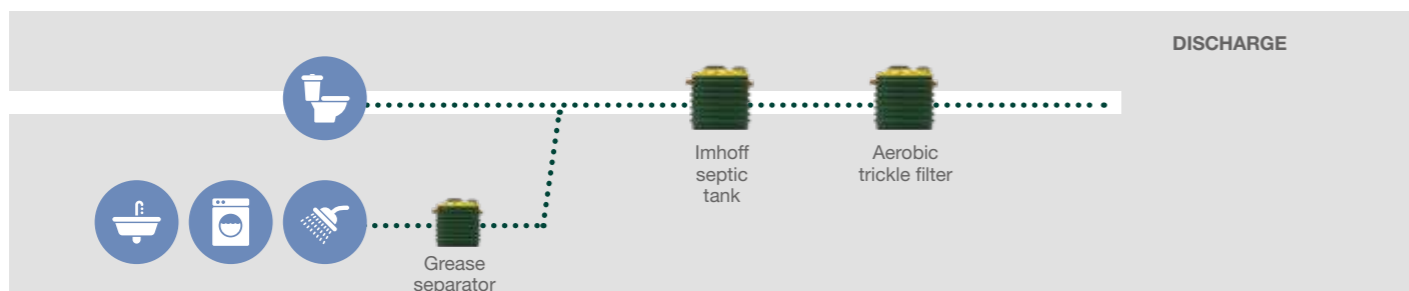

TOP OUTLET AEROBIC TRICKLE FILTERS

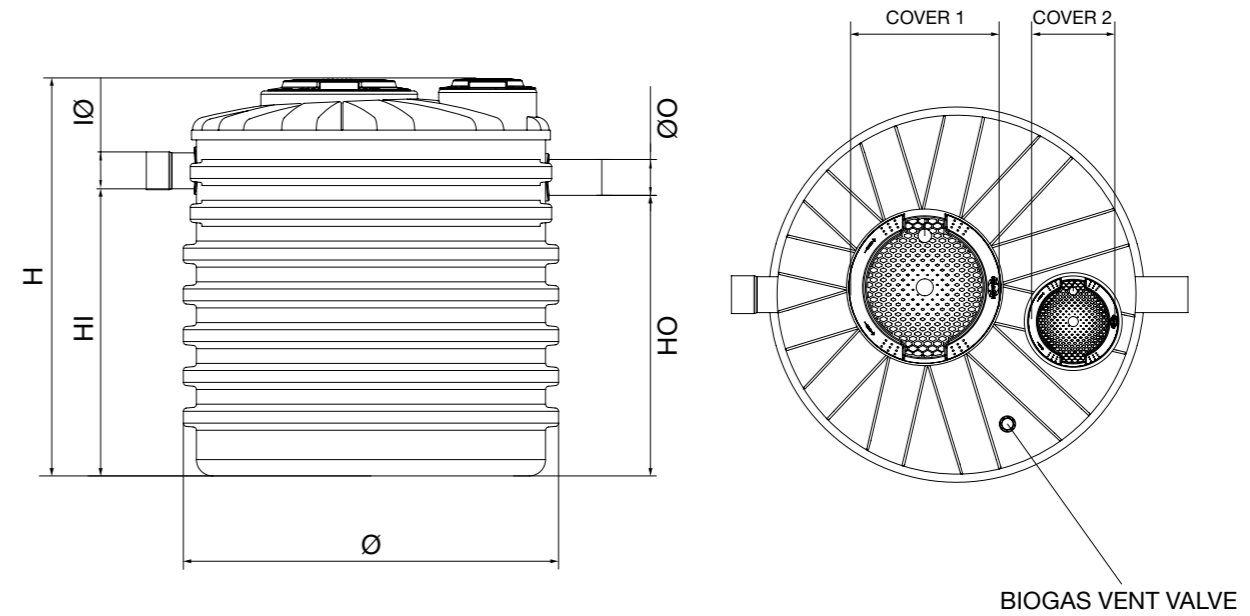

TOP OUTLET AEROBIC TRICKLE FILTERS (MODULAR TANK)

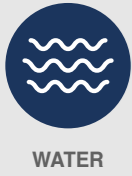
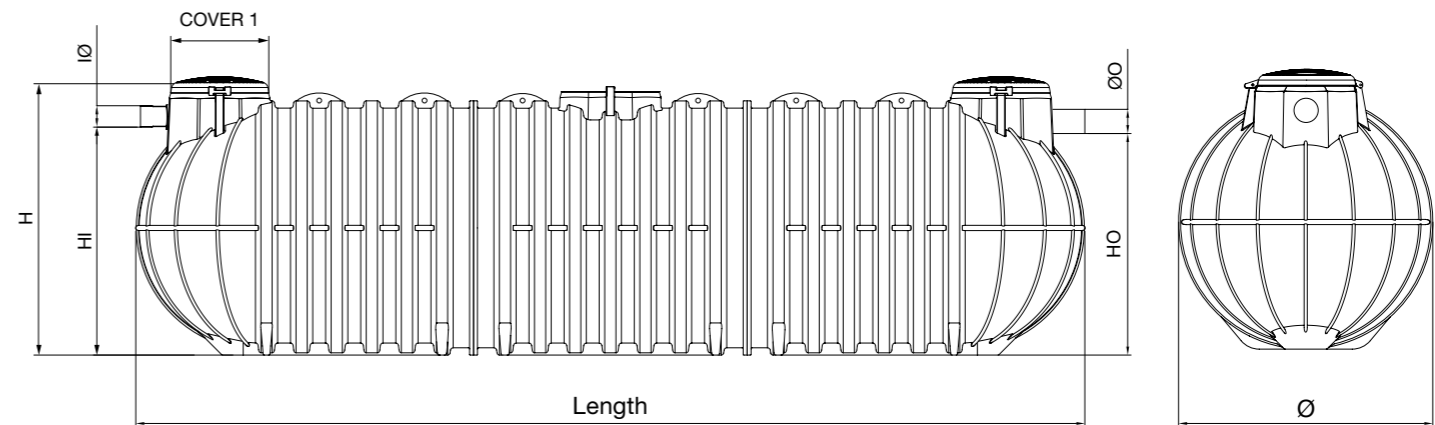

AEROBIC TRICKLE FILTER

TOP OUTLET WITH BLOWER (MBBR)

Item	Mod.	Length mm	Width mm	Ø mm	H mm	HI mm	HO mm	Ø I/O mm	Cover 1	Cover 2	Extension 1 (optional)	Extension 2 (optional)	Blower	Filter Surface m ²	Filter Volume m ³	P.E.
XARA500		-	-	950	900	720	700	110	CC400	CC130C	PP45	-	HP40	0.70	0.43	2
XARA700		-	-	1150	923	630	610	110	CC400	CC200	PP45	PP30	HP40	1.03	0.54	3
XARA900		-	-	1150	1048	750	730	110	CC400	CC200	PP45	PP30	HP40	1.03	0.66	5
XARA1000		-	-	1150	1221	933	913	110	CC400	CC200	PP45	PP30	HP40	1.03	0.85	6
NARA1200		1900	708	-	1630	1250	1230	110	CC300	CC300	PP35	PP35	HP40	1.35	1.20	7
XARA1250		-	-	1150	1478	1175	1155	110	CC400	CC200	PP45	PP30	HP40	1.03	1,10	7
NARA1700		1900	708	-	2140	1760	1740	110	CC300	CC300	PP35	PP35	HP40	1.35	1.77	10
XARA1500		-	-	1150	1779	1465	1445	110	CC400	CC300	PP45	PP35	HP40	1.03	1.40	10
new XARA1750		-	-	1350	1672	1285	1265	110	CC400	CC300	PP45	PP35	HP40	1.43	1.68	11
NARA2600		-	-	1710	1450	1000	980	125	CC400	CC300	PP45	PP35	HP60	2.30	2.06	16
NARA3200		-	-	1710	1725	1240	1220	125	CC400	CC300	PP45	PP35	HP60	2.30	2.52	20
NARA3800		-	-	1710	1955	1490	1470	125	CC400	CC300	PP45	PP35	HP60	2.30	3.10	23
NARA4600		-	-	1710	2225	1710	1690	125	CC400	CC300	PP45	PP35	HP60	2.30	3.80	28
NARA5400		-	-	1950	2250	1660	1640	125	CC400	CC400	PP45	PP45	HP60	2.90	4.75	32
NARA6400		-	-	1950	2530	1970	1950	125	CC400	CC400	PP45	PP45	HP60	2.90	5.07	38
NARA5700		2420	1920	-	2100	1690	1670	125	TAP800	-	PP77	-	HP80	3.78	5.60	42
NARA7000		-	-	2250	2367	1850	1830	125	CC400	CC400	PP45	PP45	HP80	3.98	6.93	50
NARA9000		-	-	2250	2625	2070	2050	125	CC400	CC400	PP45	PP45	HP80	3.98	7.82	56
NARA10700		2780	2430	-	2660	2170	2130	160	TAP800	-	PP77	-	HP80	6.75	10.00	80
ITARA13000		5010	-	2100	2200	1830	1800	160	TAP800	-	PP77	-	HP402SF	9.20	12.30	90
ITARA15000		5620	-	2100	2200	1830	1800	160	TAP800	-	PP77	-	HP402SF	10.20	14.15	110
ITARA18000		6680	-	2100	2200	1830	1800	160	TAP800	-	PP77	-	HP402SF	12.40	16.60	130
ITARA20000		7270	-	2100	2200	1830	1800	160	TAP800	-	PP77	-	HP402SF	13.60	18.22	140
ITARA22000		7880	-	2100	2200	1830	1800	160	TAP800	-	PP77	-	HP402SF	14.90	20.07	150
ITARA25000		8940	-	2100	2200	1830	1800	160	TAP800	-	PP77	-	HP402SF	16.80	22.51	175
ITARA28000		9530	-	2100	2200	1810	1780	200	TAP800	-	PP77	-	HP402SF	18.00	24.12	190
ITARA30000		10140	-	2100	2200	1810	1780	200	TAP800	-	PP77	-	HP502SF	19.16	27.25	210
ITARA33000		11200	-	2100	2200	1810	1780	200	TAP800	-	PP77	-	HP502SF	21.20	28.55	225
ITARA35000		11790	-	2100	2200	1810	1780	200	TAP800	-	PP77	-	HP502SF	22.40	30.10	240
ITARA36000		12400	-	2100	2200	1810	1780	200	TAP800	-	PP77	-	HP502SF	23.67	33.08	250
ITARA40000		13460	-	2100	2200	1810	1780	200	TAP800	-	PP77	-	HP502SF	25.60	34.30	275

P.E.= population equivalent; Ø= diameter; H= height; HI= inlet pipe height; HO= outlet pipe height; Ø I/O= inlet/outlet pipe diameter.

NOTES



SEWAGE



WATER



UNDERGROUND INSTALLATION



SECONDARY TREATMENT PLANT WITH SLUDGE RECIRCULATION

[FIND OUT MORE](#)



HIGH EFFICIENCY SECONDARY WITH SLUDGE RECIRCULATION

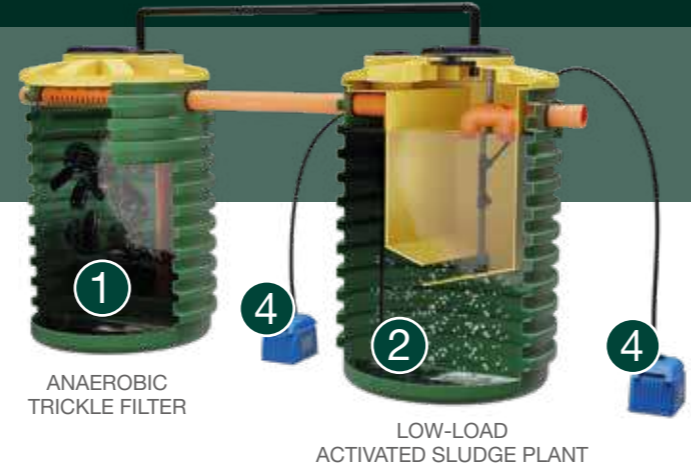

- 1 FILTER MEDIA**
Plastic bulk fill material with a large surface area that acts as a support on which the anaerobic bacteria responsible for treating the effluent can develop.
- 2 OXYGENATION AREA**
Area in which the effluent is mixed and oxygenated, thanks to micro-bubble air diffuser plates, powered by an external blower/compressor. This develops aerobic bacteria that transform the biodegradable compounds into CO₂, organic nitrogen into ammonia and ammonia into nitrates.
- 3 FINAL DISINFECTION AND SEDIMENTATION AREA**
Stilling area in which the residual sludge sediments and returns once again to the oxygenation section. A housing is present on the outlet pipe, in which to insert a slow release chlorine tablet. In this way the effluent is disinfected before being discharged.
- 4 BLOWER-COMPRESSOR**
For forced blowing of oxygen into the activated sludge plant (included).

1 ANAEROBIC TRICKLE FILTER
2 LOW-LOAD ACTIVATED SLUDGE PLANT
4

CE
UNI EN 12566-3

INSTALLATION DIAGRAM

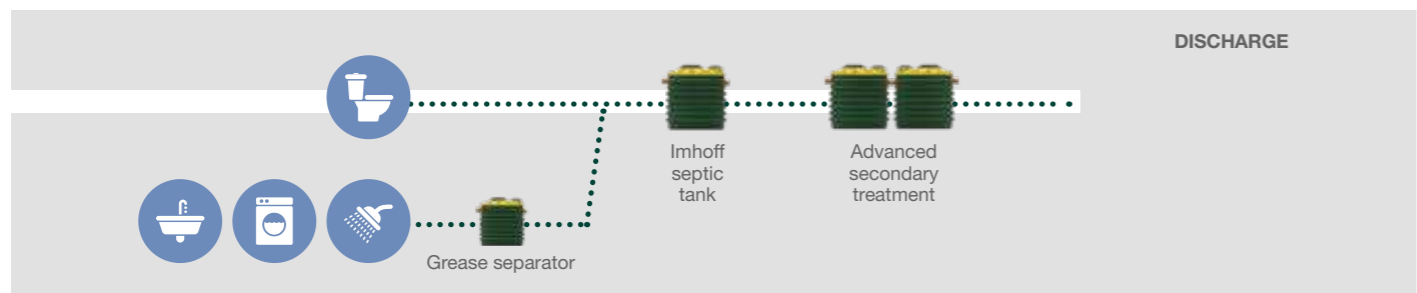

SPECIFICATIONS

TECHNICAL CHARACTERISTICS

Secondary treatments consisting of an anaerobic trickle filter and an activated sludge plant allow almost 100 % removal of the organic load and suspended solids with a very high reduction in the nitrogen load and phosphorous load found in domestic sewage. In this way, the waste water discharged respects the limits indicated in table 4 of attachment 5 to Legislative Decree 152/2006 for discharge to land. The trickle filter is a biological reactor in which the micro-organisms, under anaerobic conditions, make use of the biodegradable substance contained in the effluent. These micro-organisms develop on the surface of special bulk fill material in polypropylene, specifically designed to maximise the contact surface area between the micro-organisms and the effluent. Activated sludge plants are systems in which the bacterial flora develops in colonies that remain in suspension in the effluent and consume the remaining biodegradable material. The process is fully aerobic and the oxygen necessary for the development of the bacteria is supplied by submersed diffusers that emit a flow of fine bubbles of air from the bottom of the tank. This also guarantees continuous effluent mixing.

USE
Advanced secondary treatment of domestic sewage.

REFERENCE STANDARDS
UNI 12566-3.

SEWAGE TREATMENT EFFICIENCY

The wastewater treatment systems made up of a grease separator, an Imhoff biological tank and a high efficiency secondary treatment (installed as shown in the diagram at page 70) ensures that the concentrations of the final effluent are:

≤100 mg/l COD	≤20 mg/l BOD ₅	≤25 mg/l SS
------------------	------------------------------	----------------

These parameters are respected if the inlet wastewater have the following characteristics (typical concentrations of domestic sewage):

≤600 mg/l COD	≤300 mg/l BOD ₅	≤400 mg/l SS
------------------	-------------------------------	-----------------

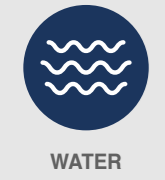

DEPURBLOK ONE-PIECE TREATMENT PLANTS

FIND OUT MORE

IFABLOK

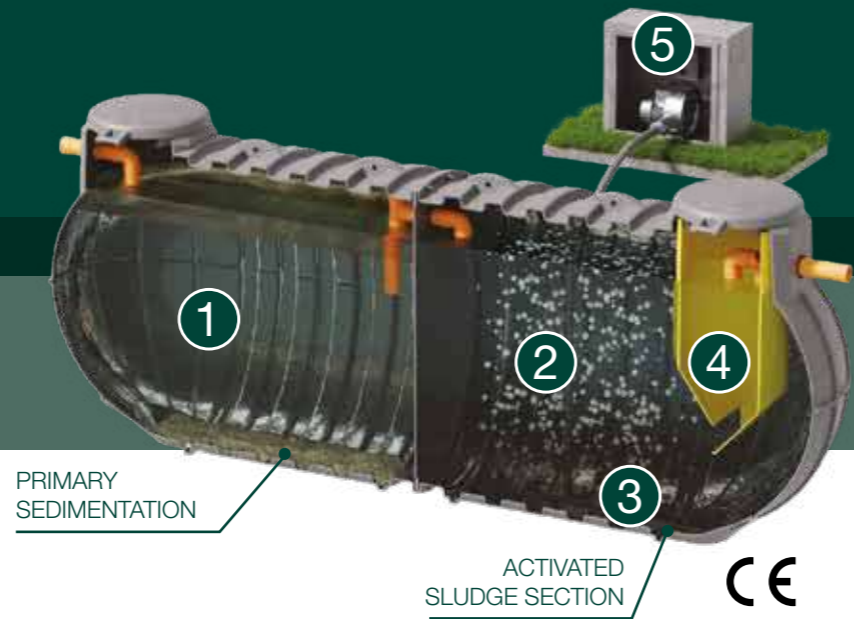

CE
UNI 12566-3

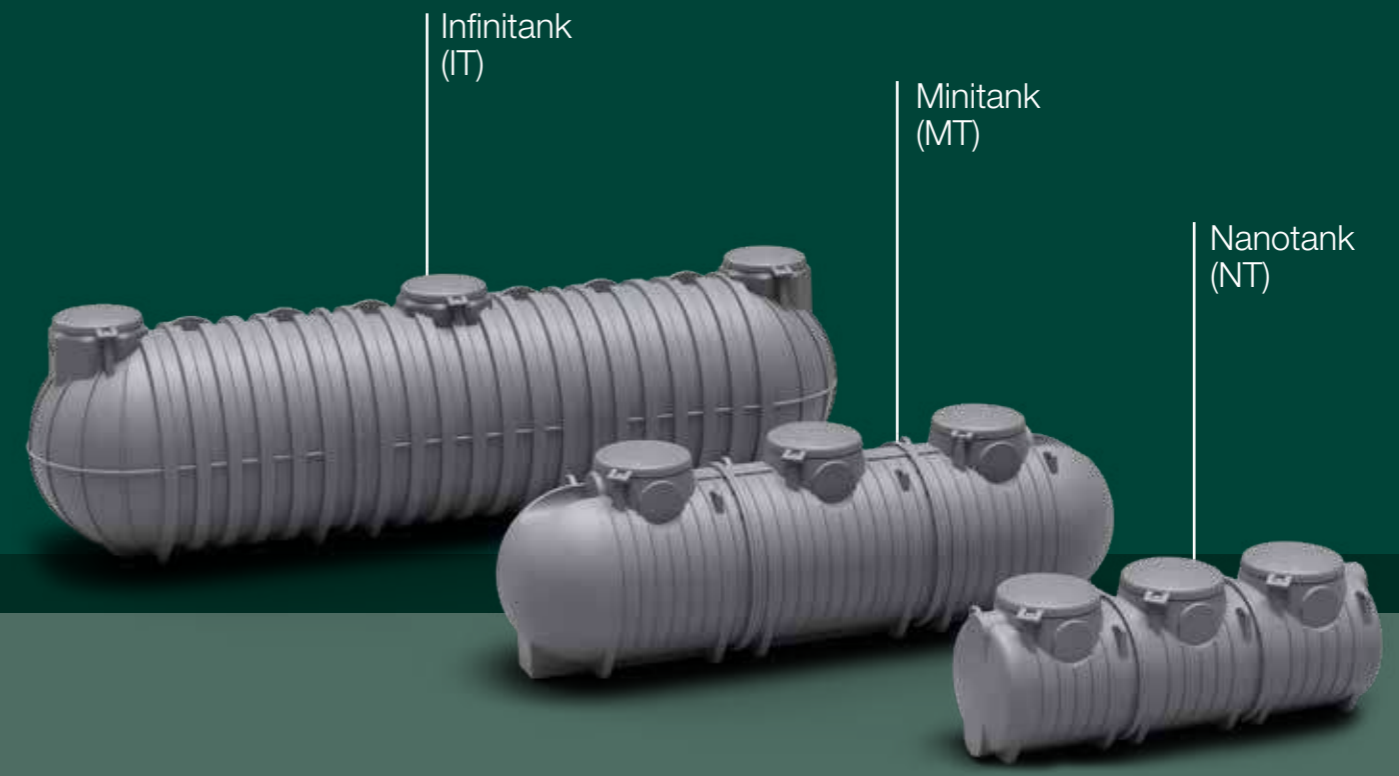

1 SEDIMENTATION AND SLUDGE DIGESTION SECTION

Stilling zone where the effluent solids settle and accumulate at the bottom of the tank. The bacterial flora transforms the putrescible component of the sludge into inert sludge, carbon dioxide and water.

2 OXIDATION SECTION

Zone into which air is blown to move and oxygenate the effluent. This is where the aerobic bacterial flora that oxidises the residual organic component and nitrogen is developed.

3 DIFFUSERS

In microbored rubber for uniform distribution of the air in the oxygenation section.

4 FINAL SEDIMENTATION

Stilling zone in which any residual sludge decants and is gravity fed to the oxidation area (only present in INFINITANK models).

5 BLOWERS - COMPRESSORS

To blow air to the oxygenation section diffusers.

INSTALLATION DIAGRAM

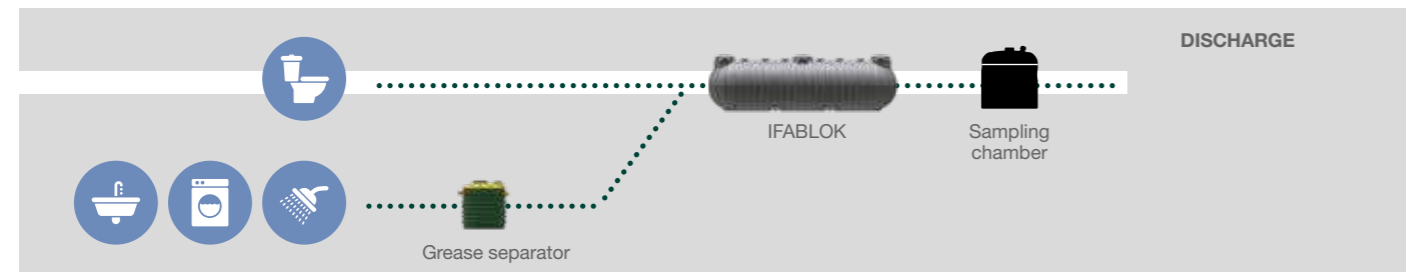

SPECIFICATIONS

TECHNICAL CHARACTERISTICS

The IFABLOK one-piece treatment plant consists of primary sedimentation and anaerobic sludge digestion in a biological tank and subsequent secondary activated sludge aerobic digestion. IFABLOK is a system that makes use of the action of the aerobic bacterial colonies which, remaining in suspension in the sewage, consume the biodegradable organic material, using it as a nutrient to obtain the necessary energy and the material required for the synthesis of new cells. An aeration system is used to guarantee the concentration of oxygen necessary to develop the biological reactions. This system consists of submerged diffusers which, from the bottom of the tank, disperse a flow of fine air bubbles. This also guarantees sufficient mixing to keep the high concentrations of solids present in the tank in suspension.

USE

Primary and secondary treatment of domestic sewage and similar.

REFERENCE STANDARDS

UNI 12566-3.



SEWAGE TREATMENT EFFICIENCY

The IFABLOK one-piece treatment plant (installed as shown in the diagram at page 74) ensures that the concentrations of the final effluent are:

≤160 mg/l
COD

≤40 mg/l
BOD₅

≤80 mg/l
SS

These parameters are respected if the inlet wastewater have the following characteristics (typical concentrations of domestic sewage):

≤600 mg/l
COD

≤300 mg/l
BOD₅

≤400 mg/l
SS

IFABLOK

NANOTANK MODEL

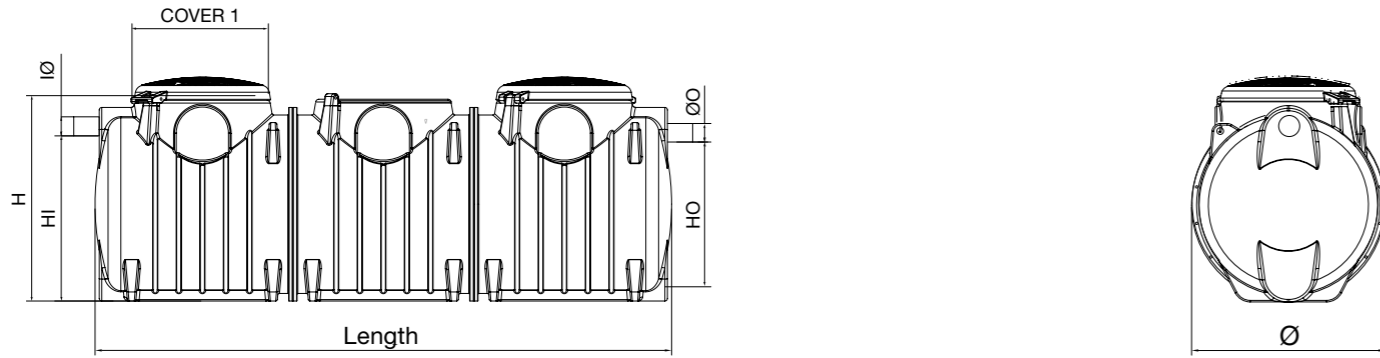

MINITANK MODEL

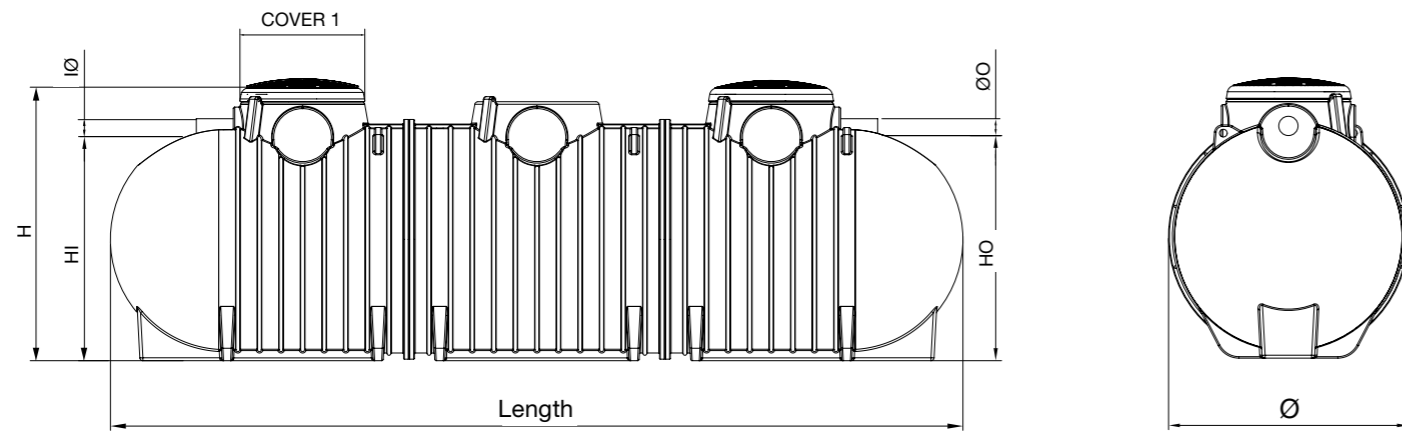

INFINITANK MODEL

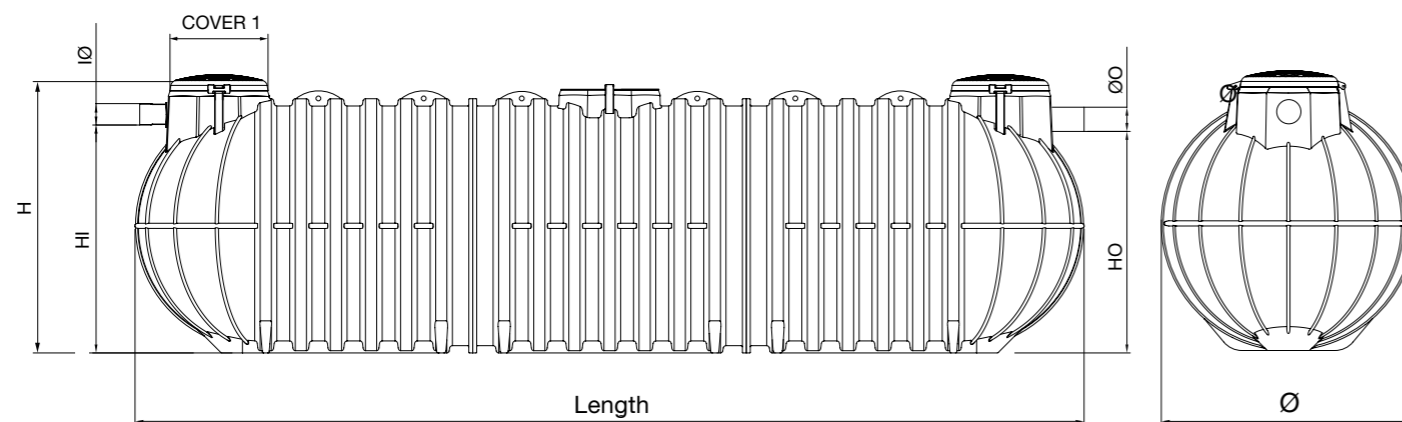

IFABLOK

Item	Model	Length mm	Ø mm	H mm	HI mm	HO mm	Ø I/O mm	Covers	Extension 1 (optional)	Sed. vol. l	Oxidation Vol. l	Blower	P.E.
NTSEIFA2000	nanotank	2350	1150	1329	960	940	125	TAP700	PP77	910	910	HP60	6
NTSEIFA3000	nanotank	3425	1150	1329	960	940	125	TAP700	PP77	910	1820	HP80	10
NTSEIFA4000	nanotank	4500	1150	1329	960	940	125	TAP700	PP77	1820	1820	HP80	13
NTSEIFA5000	nanotank	5575	1150	1329	960	940	125	TAP700	PP77	1820	2730	HP150	16
MTSEIFA6000	minitank	3870	1550	1710	1420	1400	125	TAP800	PP77	2780	2780	HP200	20
MTSEIFA9000	minitank	5520	1550	1710	1420	1400	125	TAP800	PP77	2780	5560	HP302SF	30
ITSEIFA11000	infinitant	4420	2100	2200	1870	1850	160	TAP800	PP77	5000	5000	HP302SF	35
MTSEIFA12000	minitank	7180	1550	1710	1420	1400	125	TAP800	PP77	5560	5560	HP302SF	40
ITSEIFA13000	infinitant	5010	2100	2200	1870	1850	160	TAP800	PP77	5000	7000	HP302SF	45
ITSEIFA15000	infinitant	5620	2100	2200	1870	1850	160	TAP800	PP77	7000	7000	HP302SF	50
ITSEIFA18000	infinitant	6680	2100	2200	1870	1850	160	TAP800	PP77	5000	12000	HP402SF	58
ITSEIFA20000	infinitant	7270	2100	2200	1870	1850	160	TAP800	PP77	7000	12000	HP402SF	65
ITSEIFA22000	infinitant	7880	2100	2200	1870	1850	160	TAP800	PP77	7000	14000	HP402SF	72
ITSEIFA25000	infinitant	8940	2100	2200	1870	1850	160	TAP800	PP77	12000	12000	HP402SF	80
ITSEIFA28000	infinitant	9530	2100	2200	1870	1850	160	TAP800	PP77	12000	14000	HP402SF	90
ITSEIFA30000	infinitant	10140	2100	2200	1870	1850	160	TAP800	PP77	14000	14000	HP402SF	95
ITSEIFA33000	infinitant	11200	2100	2200	1870	1850	160	TAP800	PP77	12000	19000	HP402SF	100
ITSEIFA35000	infinitant	11790	2100	2200	1870	1850	160	TAP800	PP77	12000	21000	HP402SF	110
ITSEIFA36000	infinitant	12400	2100	2200	1870	1850	160	TAP800	PP77	14000	21000	HP402SF	122
ITSEIFA40000	infinitant	13460	2100	2200	1870	1850	160	TAP800	PP77	19000	19000	HP402SF	132

P.E.= population equivalent; Ø= diameter; H= height; HI= inlet pipe height; HO= outlet pipe height; Ø I/O= inlet/outlet pipe diameter.

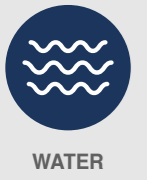

DEPURBLOK ONE-PIECE TREATMENT PLANTS

FIND OUT MORE



SEWAGE



WATER



UNDERGROUND INSTALLATION



PRIMARY SEDIMENTATION

SECTION WITH ANAEROBIC TRICKLE FILTER

CE
UNI 12566-3

1 SEDIMENTATION AND SLUDGE DIGESTION SECTION

Stilling area in which the solid part of the effluent sediments and accumulates on the bottom. This is where a bacterial flora develops that transforms the putrescible material in the sludge into inert sludge, carbon dioxide and water.

2 DISTRIBUTION PIPE

Perforated pipe for even distribution of the effluent onto the surface of the filter.

3 FILTER MEDIA

Plastic bulk fill material with a large surface area that acts as a support on which the anaerobic bacteria responsible for treating the effluent can develop.

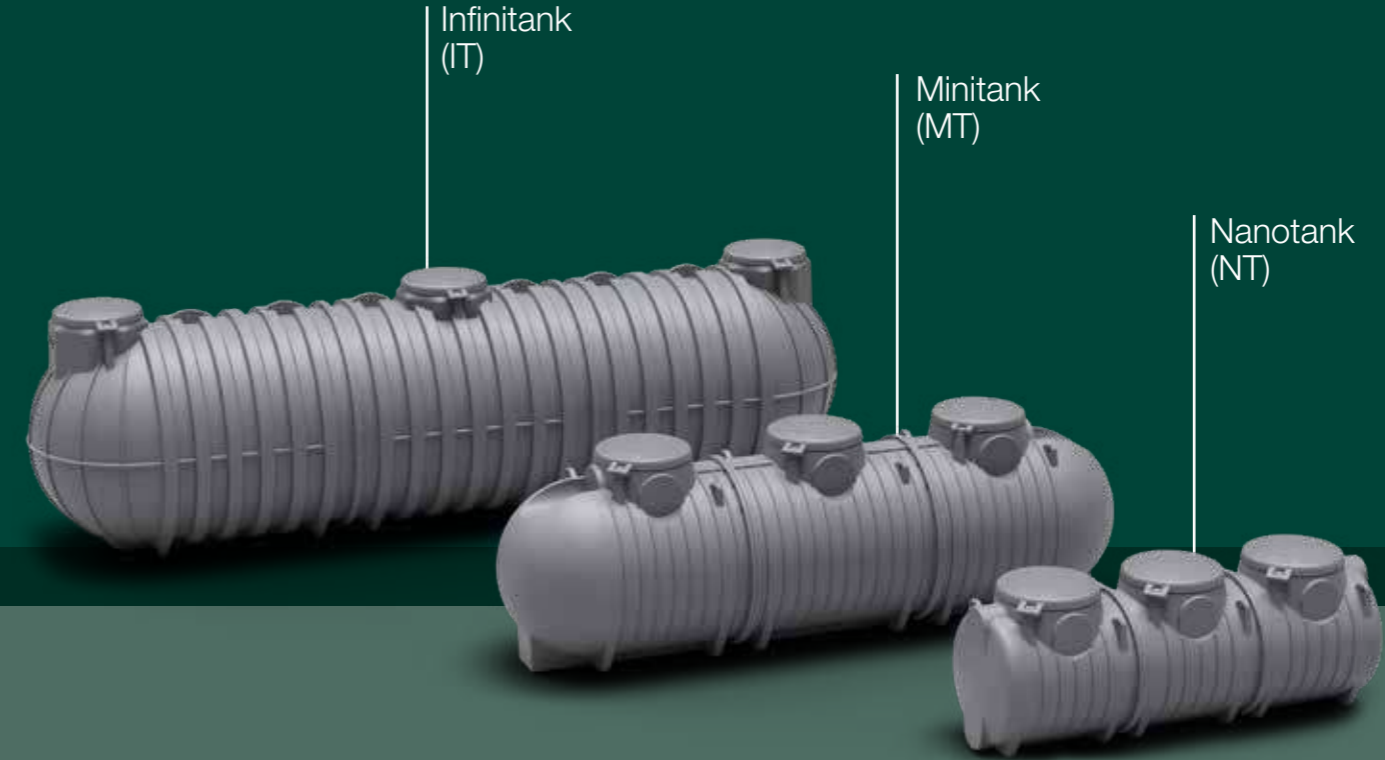

Infinitank (IT)

Minitank (MT)

Nanotank (NT)

GREASE SEPARATORS
IMHOFF BIOLOGICAL TANKS
ABOVE-GROUND TANKS
BIOLOGICAL SEPTIC TANKS
ACTIVATED SLUDGE PLANT
ABOVE-GROUND MODULAR FIREFIGHTING TANKS
ACCESSORIES
TRICKLE FILTERS
SECONDARY TREATMENT PLANT
UNDERGROUND TANKS
CONSTRUCTION SITE EQUIPMENT
DEPURBLOK
DEPURBLOK
DEPURBLOK
RAINWATER HARVESTING AND RE-USE SYSTEMS
OIL DISPOSAL UNIT
STORMWATER MANAGEMENT
CAR WASH PLANTS
CHAMBERS
LIFT STATIONS
CHAMBERS
TECHNICAL SECTION
NON-STANDARD SOLUTIONS

SPECIFICATIONS

TECHNICAL CHARACTERISTICS

The ANABLOK one-piece treatment plant consists of primary sedimentation and anaerobic sludge digestion in a biological tank and subsequent secondary treatment through an anaerobic trickle filter.

ANABLOK is a biological reactor, inside which the micro-organisms that purify the effluent develop on the surface of special scattered bulk fill material (filter media). The uniform distribution of the effluent through the filter guarantees maximum contact between the organic material to purify and the biological film covering the spheres making up the fill material. The filter media is manufactured in polypropylene and is designed to provide a large surface area available for bacterial micro-organisms to take root. This solution minimises the risk of clogging the bed.

USE

Primary and secondary treatment of domestic sewage and similar.

REFERENCE STANDARDS

UNI 12566-3.

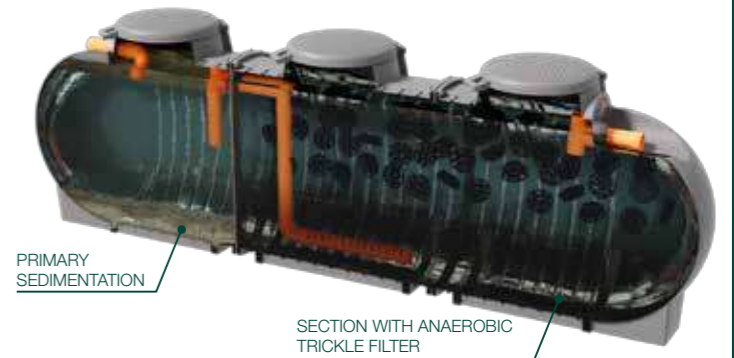

PRIMARY SEDIMENTATION

SECTION WITH ANAEROBIC TRICKLE FILTER

SEWAGE TREATMENT EFFICIENCY

The ANABLOK one-piece treatment plant (installed as shown in the diagram at page 78) ensures that the concentrations of the final effluent are:

≤160 mg/l
COD

≤40 mg/l
BOD₅

≤80 mg/l
SS

These parameters are respected if the inlet wastewater have the following characteristics (typical concentrations of domestic sewage):

≤600 mg/l
COD

≤300 mg/l
BOD₅

≤400 mg/l
SS

INSTALLATION DIAGRAM

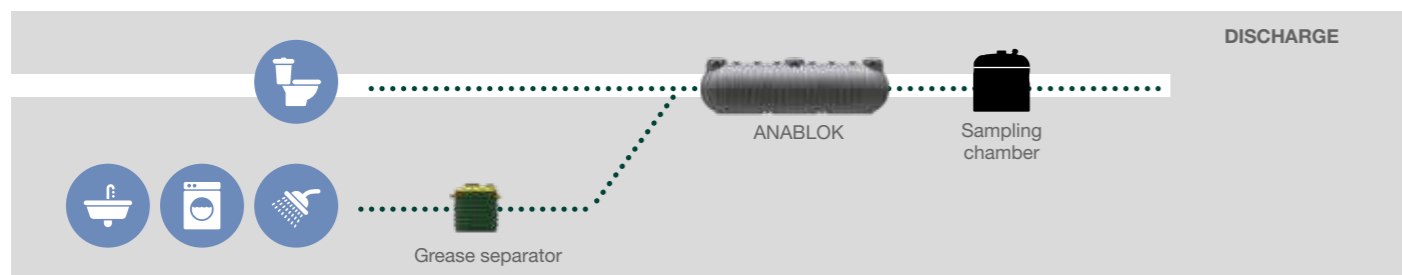

ANABLOK

NANOTANK MODEL

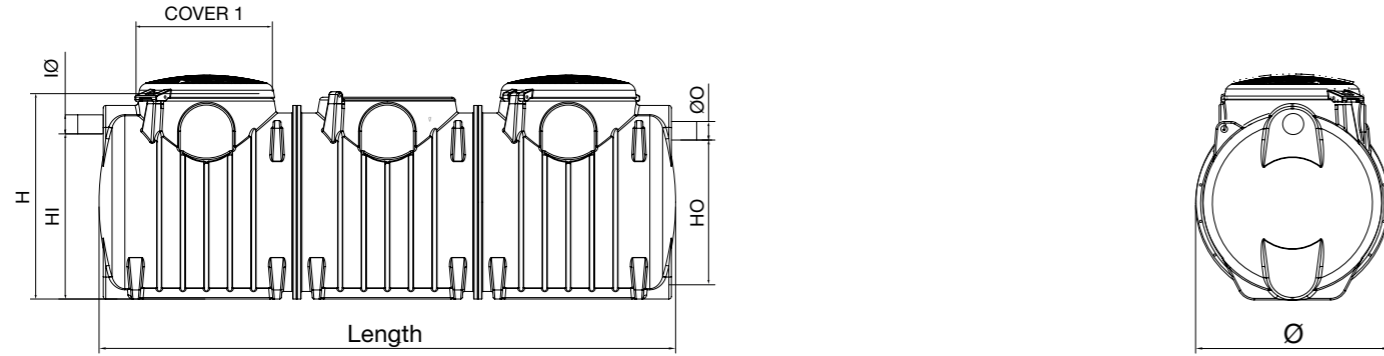

MINITANK MODEL

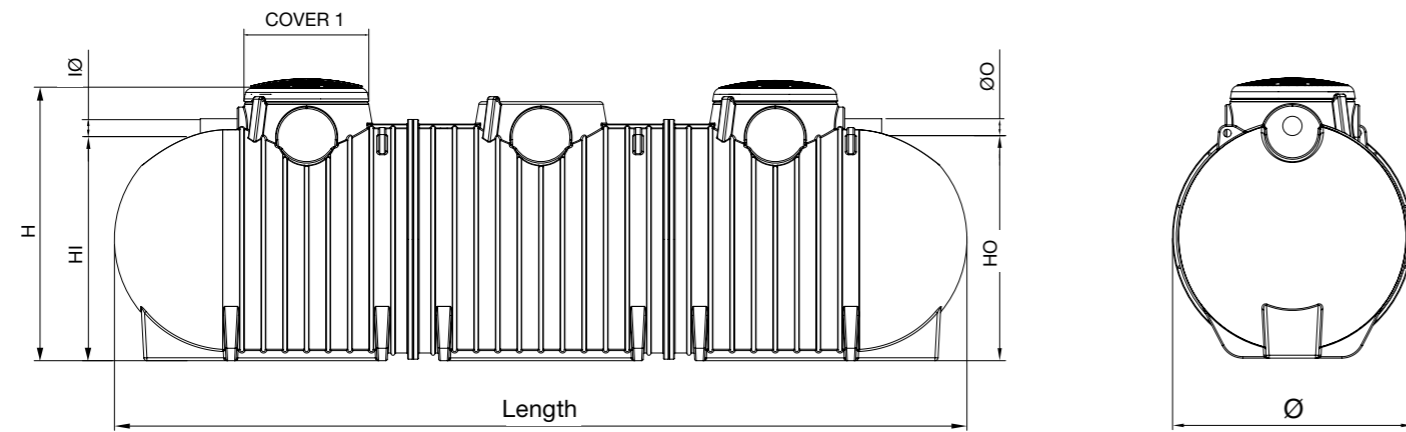

INFINITANK MODEL

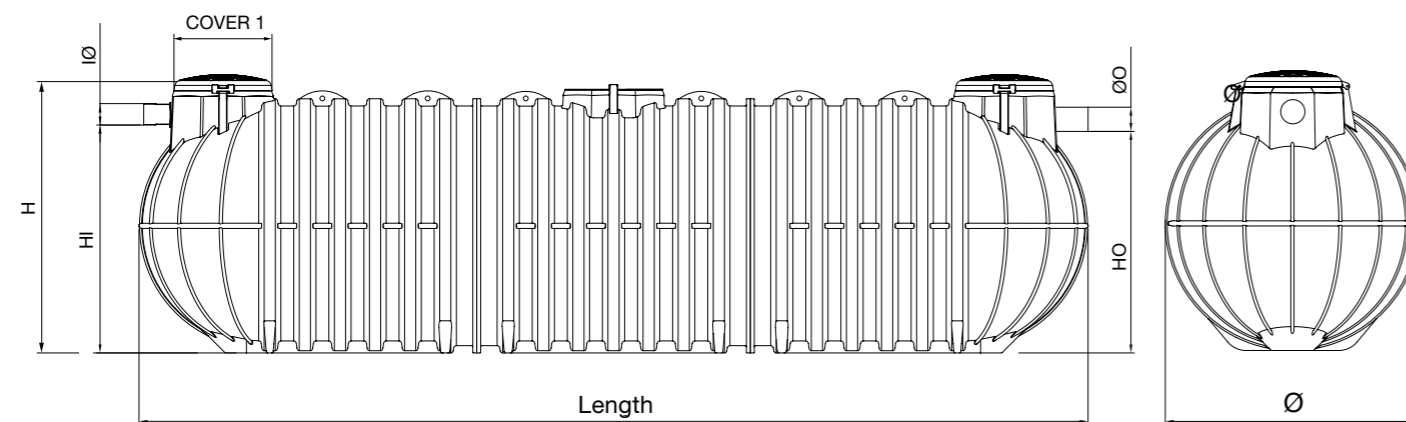

ANABLOK

Item	Model	Length mm	Ø mm	H mm	HI mm	HO mm	Ø I/O mm	Covers	Extension 1 (optional)	Sed. vol. l	Filtration Vol. l	Filter Surface sq.m.	P.E.
NTSEAN2000	nanotank	2350	1150	1329	960	940	125	TAP700	PP77	910	910	1.4	6
NTSEAN3000	nanotank	3425	1150	1329	960	940	125	TAP700	PP77	910	1820	2.8	10
NTSEAN4000	nanotank	4500	1150	1329	960	940	125	TAP700	PP77	1820	1820	2.8	13
NTSEAN5000	nanotank	5575	1150	1329	960	940	125	TAP700	PP77	1820	2730	4.2	16
MTSEAN6000	minitank	3870	1550	1710	1420	1400	125	TAP800	PP77	2780	2780	2.6	20
MTSEAN9000	minitank	5520	1550	1710	1420	1400	125	TAP800	PP77	2780	5560	5.2	30
ITSEAN11000	infinitank	4420	2100	2200	1870	1850	160	TAP800	PP77	5000	5000	4.2	35
MTSEAN12000	minitank	7180	1550	1710	1420	1400	125	TAP800	PP77	5560	5560	5.2	40
ITSEAN13000	infinitank	5010	2100	2200	1870	1850	160	TAP800	PP77	5000	7000	5.2	45
ITSEAN15000	infinitank	5620	2100	2200	1870	1850	160	TAP800	PP77	7000	7000	5.1	50
ITSEAN18000	infinitank	6680	2100	2200	1870	1850	160	TAP800	PP77	5000	12000	9.3	58
ITSEAN20000	infinitank	7270	2100	2200	1870	1850	160	TAP800	PP77	7000	12000	9.3	65
ITSEAN22000	infinitank	7880	2100	2200	1870	1850	160	TAP800	PP77	7000	14000	10.2	72
ITSEAN25000	infinitank	8940	2100	2200	1870	1850	160	TAP800	PP77	12000	12000	9.3	80
ITSEAN28000	infinitank	9530	2100	2200	1870	1850	160	TAP800	PP77	12000	14000	10.2	90
ITSEAN30000	infinitank	10140	2100	2200	1870	1850	160	TAP800	PP77	14000	14000	10.2	95
ITSEAN33000	infinitank	11200	2100	2200	1870	1850	160	TAP800	PP77	12000	19000	14.4	100
ITSEAN35000	infinitank	11790	2100	2200	1870	1850	160	TAP800	PP77	12000	21000	15.3	110
ITSEAN36000	infinitank	12400	2100	2200	1870	1850	160	TAP800	PP77	14000	21000	15.3	122
ITSEAN40000	infinitank	13460	2100	2200	1870	1850	160	TAP800	PP77	19000	19000	14.4	132

P.E.= population equivalent; Ø= diameter; H= height; HI= inlet pipe height; HO= outlet pipe height; Ø I/O = inlet/outlet pipe diameter.



DEPURBLOK ONE-PIECE TREATMENT PLANTS

FIND OUT MORE

BIOBLOK

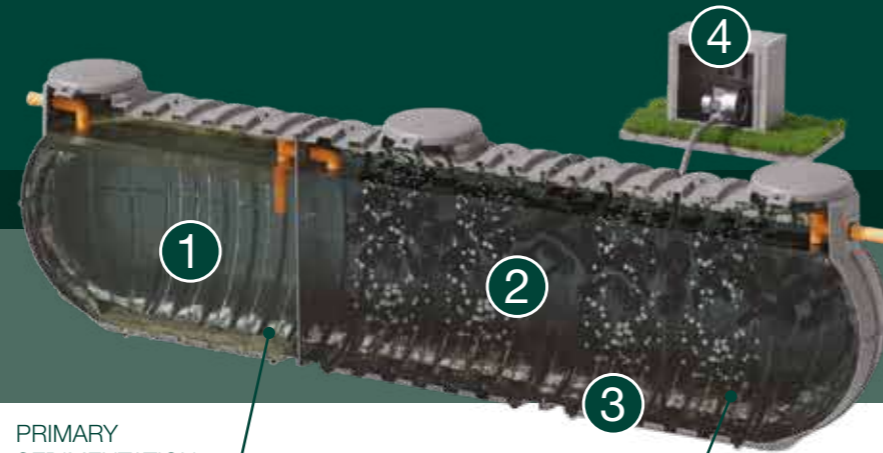

1 PRIMARY SEDIMENTATION

2 SECTION WITH AERATED TRICKLE FILTER (MBBR)

CE
UNI 12566-3

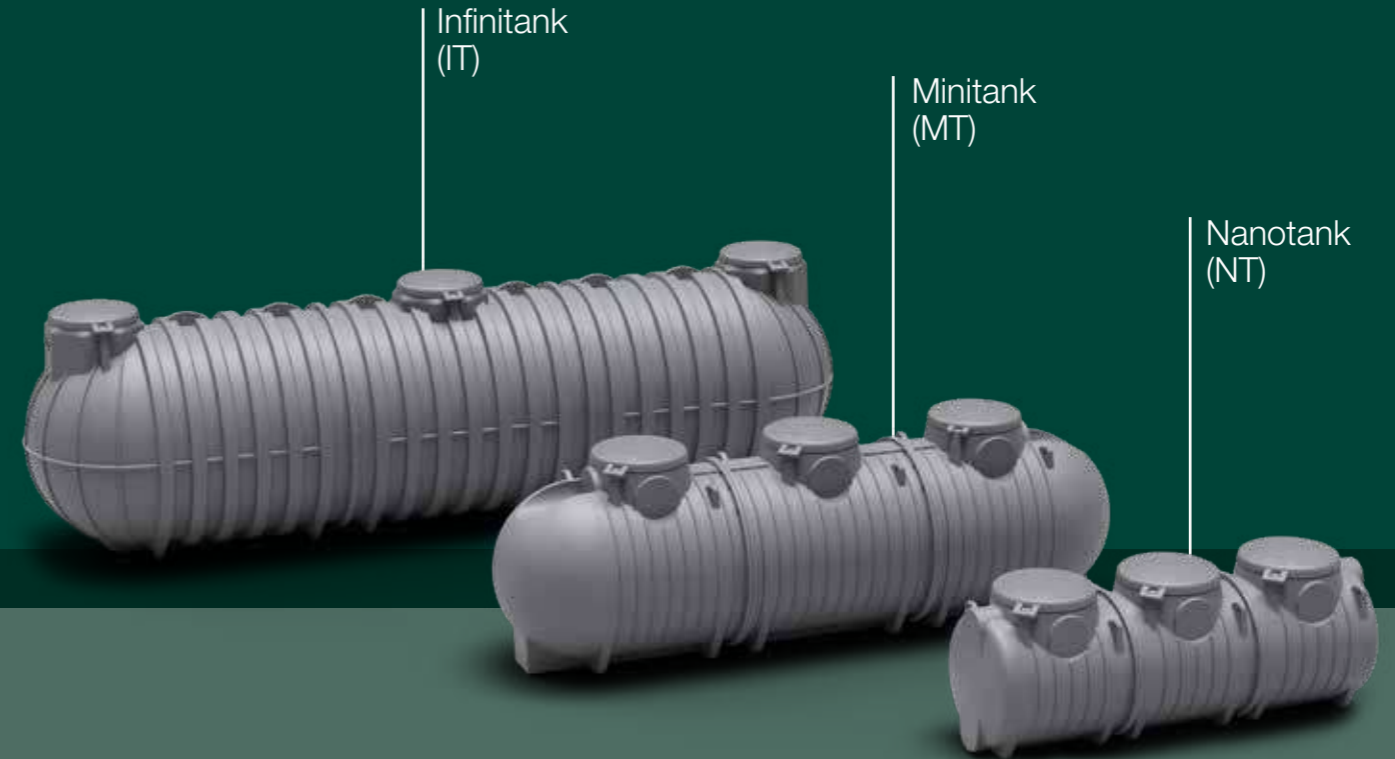

Infinitank (IT)

Minitank (MT)

Nanotank (NT)

- 1 SEDIMENTATION AND SLUDGE DIGESTION SECTION**
Stilling zone where the effluent solids settle and accumulate at the bottom of the tank. The bacterial flora transforms the putrescible component of the sludge into inert sludge, carbon dioxide and water.
- 2 FILTER MEDIA**
Plastic bulk fill material with a large surface area that acts as a support on which the aerobic bacteria responsible for treating the effluent can develop.
- 3 DIFFUSERS**
In microbored rubber for uniform distribution of the air in the oxygenation section.
- 4 BLOWERS - COMPRESSORS**
To blow air to the oxygenation section diffusers.

INSTALLATION DIAGRAM

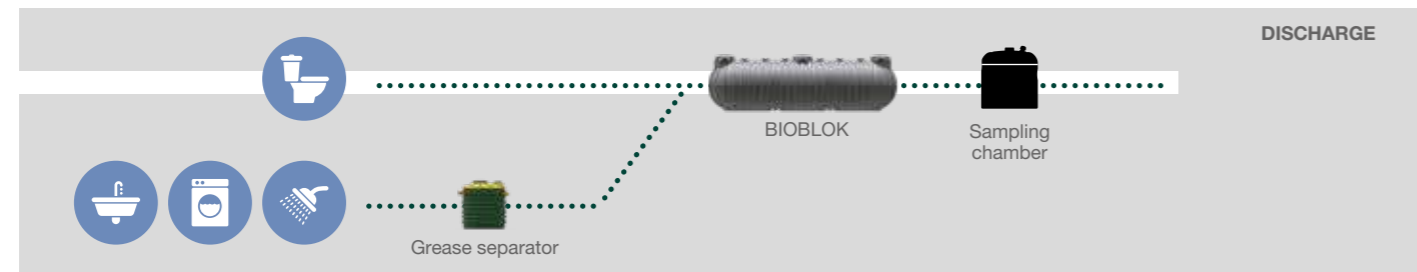

SPECIFICATIONS

TECHNICAL CHARACTERISTICS

The BIOBLOK one-piece treatment plant consists of primary sedimentation and anaerobic sludge digestion in a biological tank and subsequent secondary adhered biomass aerobic digestion. BIOBLOK is a biological reactor, inside which the micro-organisms that purify the effluent develop on the surface of special scattered bulk fill material (filter media). The uniform distribution of the effluent through the filter guarantees maximum contact between the organic material to purify and the biological film covering the spheres making up the fill material. More specifically, the bacteria that grow and develop inside the top outlet aerobic trickle filter consume the organic load in the effluent in the presence of oxygen. The oxygen enters the tank continuously through the external compressor and is distributed by the diffuser plates.

USE

Primary and secondary treatment of domestic sewage and similar.

REFERENCE STANDARDS

UNI 12566-3.

SEWAGE TREATMENT EFFICIENCY

The BIOBLOK one-piece treatment plant (installed as shown in the diagram at page 82) ensures that the concentrations of the final effluent are:

≤160 mg/l COD ≤40 mg/l BOD₅ ≤80 mg/l SS

But also ensures these final concentration according to the number of PE indicated in PE T4 column of the table at page __

≤100 mg/l COD ≤20 mg/l BOD₅ ≤25 mg/l SS

All these parameters are respected if the inlet wastewater have the following characteristics (typical concentrations of domestic sewage):

≤600 mg/l COD ≤300 mg/l BOD₅ ≤400 mg/l SS

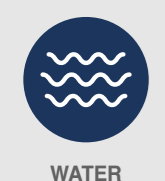

BIOBLOK

NANOTANK MODEL

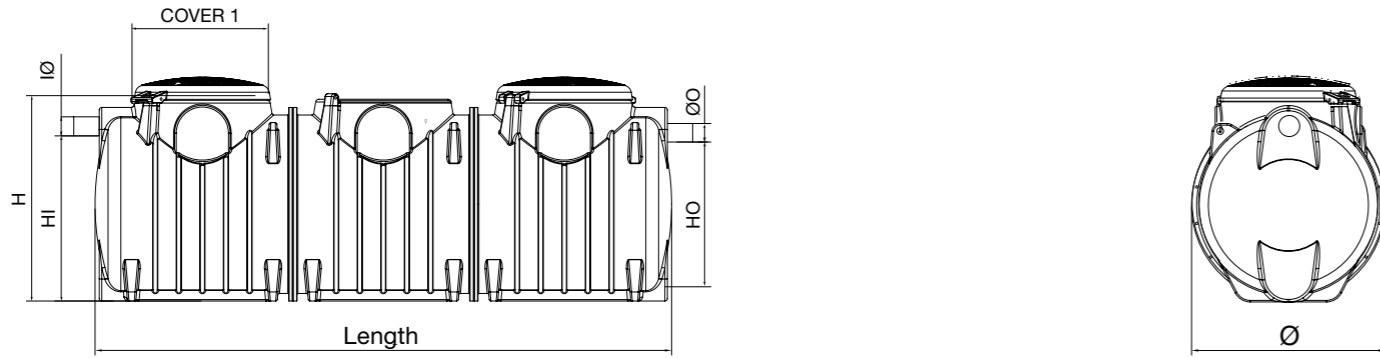

MINITANK MODEL

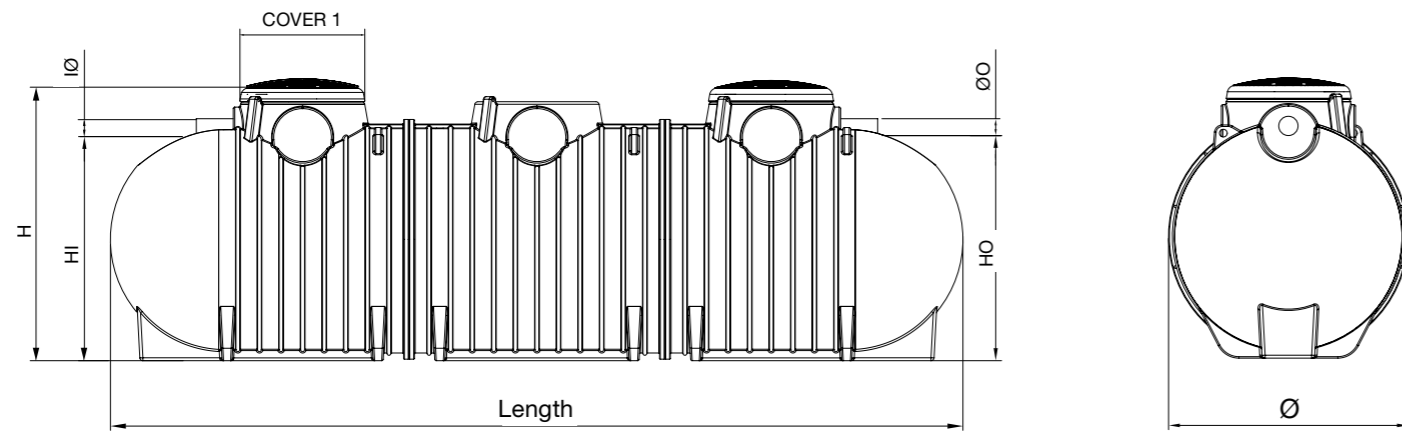

INFINITANK MODEL

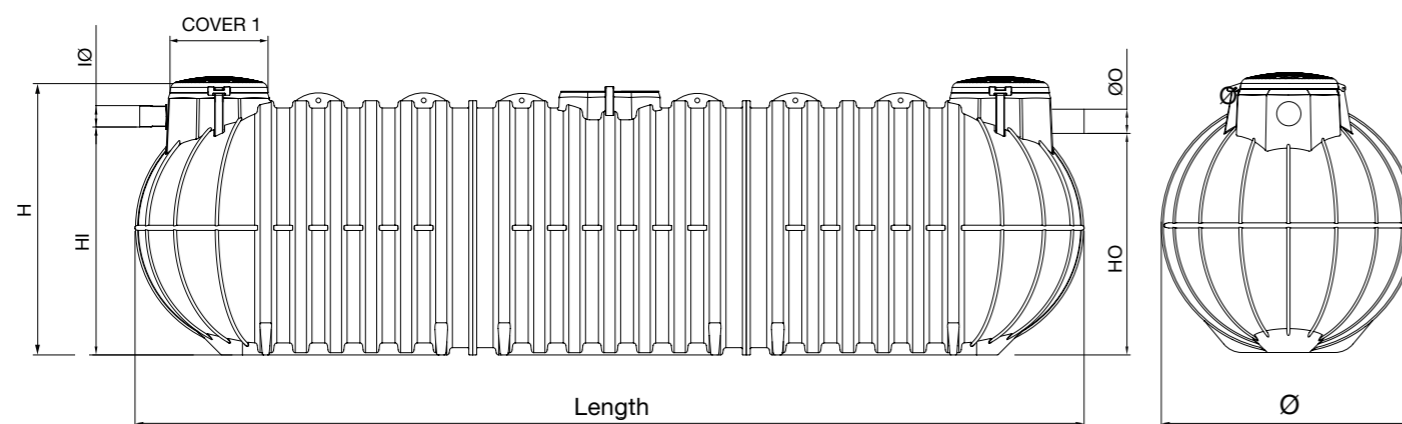

BIOBLOK

Item	Model	Length mm	Ø mm	H mm	HI mm	HO mm	Ø I/O mm	Covers	Extension 1 (optional)	Sed. vol. l	Filtration Vol. l	Blower	P.E.
NTSEARA2000	nanotank	2350	1150	1329	960	940	125	TAP700	PP77	910	910	HP60	6
NTSEARA3000	nanotank	3425	1150	1329	960	940	125	TAP700	PP77	910	1820	HP80	10
NTSEARA4000	nanotank	4500	1150	1329	960	940	125	TAP700	PP77	1820	1820	HP80	14
NTSEARA5000	nanotank	5575	1150	1329	960	940	125	TAP700	PP77	1820	2730	HP150	18
MTSEARA6000	minitank	3870	1550	1710	1420	1400	125	TAP800	PP77	2780	2780	HP200	24
MTSEARA9000	minitank	5520	1550	1710	1420	1400	125	TAP800	PP77	2780	5560	HP302SF	35
ITSEARA11000	infitank	4420	2100	2200	1870	1850	160	TAP800	PP77	5000	5000	HP302SF	40
MTSEARA12000	minitank	7180	1550	1710	1420	1400	125	TAP800	PP77	5560	5560	HP302SF	48
ITSEARA13000	infitank	5010	2100	2200	1870	1850	160	TAP800	PP77	5000	7000	HP302SF	50
ITSEARA15000	infitank	5620	2100	2200	1870	1850	160	TAP800	PP77	7000	7000	HP302SF	58
ITSEARA18000	infitank	6680	2100	2200	1870	1850	160	TAP800	PP77	5000	12000	HP402SF	65
ITSEARA20000	infitank	7270	2100	2200	1870	1850	160	TAP800	PP77	7000	12000	HP402SF	75
ITSEARA22000	infitank	7880	2100	2200	1870	1850	160	TAP800	PP77	7000	14000	HP402SF	80
ITSEARA25000	infitank	8940	2100	2200	1870	1850	160	TAP800	PP77	12000	12000	HP402SF	90
ITSEARA28000	infitank	9530	2100	2200	1870	1850	160	TAP800	PP77	12000	14000	HP402SF	100
ITSEARA30000	infitank	10140	2100	2200	1870	1850	160	TAP800	PP77	14000	14000	HP402SF	110
ITSEARA33000	infitank	11200	2100	2200	1870	1850	160	TAP800	PP77	12000	19000	HP402SF	122
ITSEARA35000	infitank	11790	2100	2200	1870	1850	160	TAP800	PP77	12000	21000	HP402SF	132
ITSEARA36000	infitank	12400	2100	2200	1870	1850	160	TAP800	PP77	14000	21000	HP402SF	140
ITSEARA40000	infitank	13460	2100	2200	1870	1850	160	TAP800	PP77	19000	19000	HP402SF	150

P.E.= population equivalent; Ø= diameter; H= height; HI= inlet pipe height; HO= outlet pipe height; Ø I/O = inlet/outlet pipe diameter.

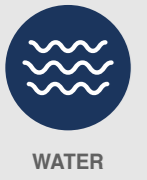

DEPURO



SEWAGE



WATER



UNDERGROUND INSTALLATION



Over the years, Rototec S.p.A. has always felt the need to distinguish itself on the Italian and international markets, investing its resources in research and in updating its own production to meet European standards, in order to provide its customers with increasingly high performance and reliable waste water treatment systems that will contribute even more to protecting the land.



To do this, Rototec has created the new DEPURO range of CE marked and UNI EN 12566-3 certified treatment plants.

DEPURO ONE AND DEPURO PLUS are designed, tested and certified under European standard UNI EN 12566:3 (Small waste water treatment systems of up to 50 PT - Part 3: pre-assembled and/or site assembled domestic waste water treatment plants). The tests were carried out at the German PIA GmbH NB 1739 laboratory which issued the certificate for the system in accordance with the European standard.

UNI EN 12566-3, in fact, specifies a series of tests that CAN ONLY be carried out by European accredited and qualified laboratories. In our case, the choice fell on "PIA GmbH – Waste water System Testing and Certification Institute" in Aachen (Germany), NB 1739.

THE DEPURO SYSTEMS WERE SUBJECTED TO THE FOLLOWING TESTS:

TREATMENT EFFICIENCY TEST:

The plants were tested in normal operating conditions for 38 weeks, with samples taken at the inlet and outlet to assess the removal percentages and determine the true efficiency of the treatment. The systems were tested at the PIA laboratory test site.

WATER TIGHTNESS TEST:

Carried out at our works by a PIA qualified technician. All the tanks in the Depuro range and their associated fittings were subjected to a water tightness test. The test has a duration of 30 minutes, during which the absence of leaks of any type is verified.

STRUCTURAL BEHAVIOUR TEST (PIT TEST):

Simulation of an underground installation with a strength test carried out on the plant. The test, lasting for 3 weeks, was carried out at the PIA laboratory test site.

WHY CHOOSE DEPURO?

100% MADE IN ITALY
DEPURO is the first range of certified treatment plants to be manufactured in polyethylene and **made entirely in Italy.**

RESPECT FOR THE ENVIRONMENT
Polyethylene is a **100% recyclable** material

HIGH ON SITE SAFETY
The light weight of the products makes moving and installing them **easier and safer.**

STRENGTH
The tanks have a very strong and durable **one-piece structure.**

OPERATING GUARANTEE
The tests carried out according to the European standard under the control of an accredited laboratory certify **the actual sewage treatment levels** of the system.

CERTIFIED



DEPURO ONE

[FIND OUT MORE](#)



- 1 SEDIMENTATION**
Sedimentation area for incoming solids.
- 2 DIGESTION**
Area into which the treated effluent flows for digestion.
- 3 SLUDGE**
Area in which the biological sludge responsible for purifying the effluent is formed.
- 4 SEDIMENTATION AREA**
Stilling area in which the residual sludge sediments and returns once again to the primary sedimentation tank.
- 5 OXYGENATION AREA**
Area in which the effluent is mixed and oxygenated, thanks to air diffuser plates. This develops aerobic bacteria that transform the biodegradable compounds into CO₂, organic nitrogen into ammonia and ammonia into nitrates.
- 6 PIPE DIFFUSERS**
Micro-bubble air diffusers (included).
- 7 SLUDGE RETURN**
Air-lift system to return the sludge that has settled in the primary sedimentation tank.
- 8 RECIRCULATION BLOWER**
included.
- 9 ELECTRIC PANEL**
serving the blowers. Fitted with timer and an audible/visual alarm (included).
- 10 OXYGENATION BLOWER**
used to blow air into the oxygenation area through the diffusers (included).

TECHNICAL CHARACTERISTICS

DEPURO ONE is a fully biological treatment system for domestic effluent and the like. It consists of two tanks: a primary tank for separation, digestion and sludge accumulation (primary sedimentation tank) and an oxydation tank with recirculation to oxidise the pollutants present in the effluent. Both tanks are made of polyethylene (PE) manufactured using rotational moulding technology.

USE

Primary and secondary treatment of domestic and assimilable sewage.

PRODUCT CERTIFICATION

UNI EN 12566/3: pre- and/or site assembled domestic waste water treatment systems

INSTALLATION DIAGRAM

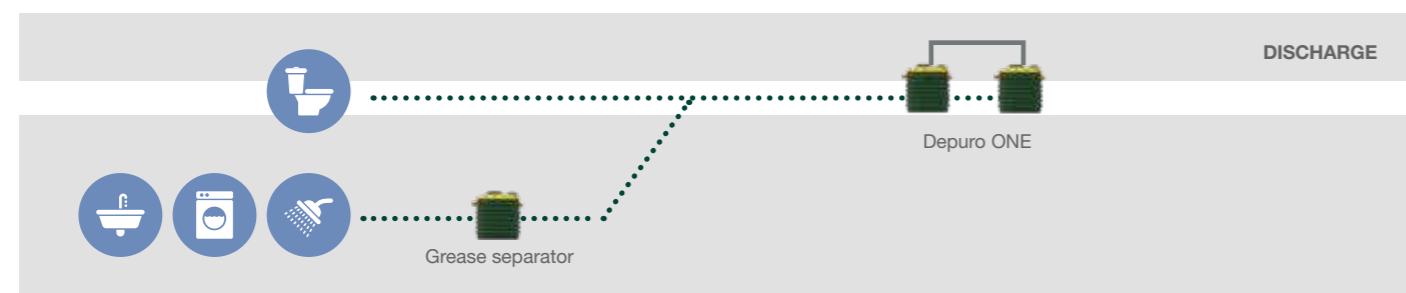

DEPURO ONE

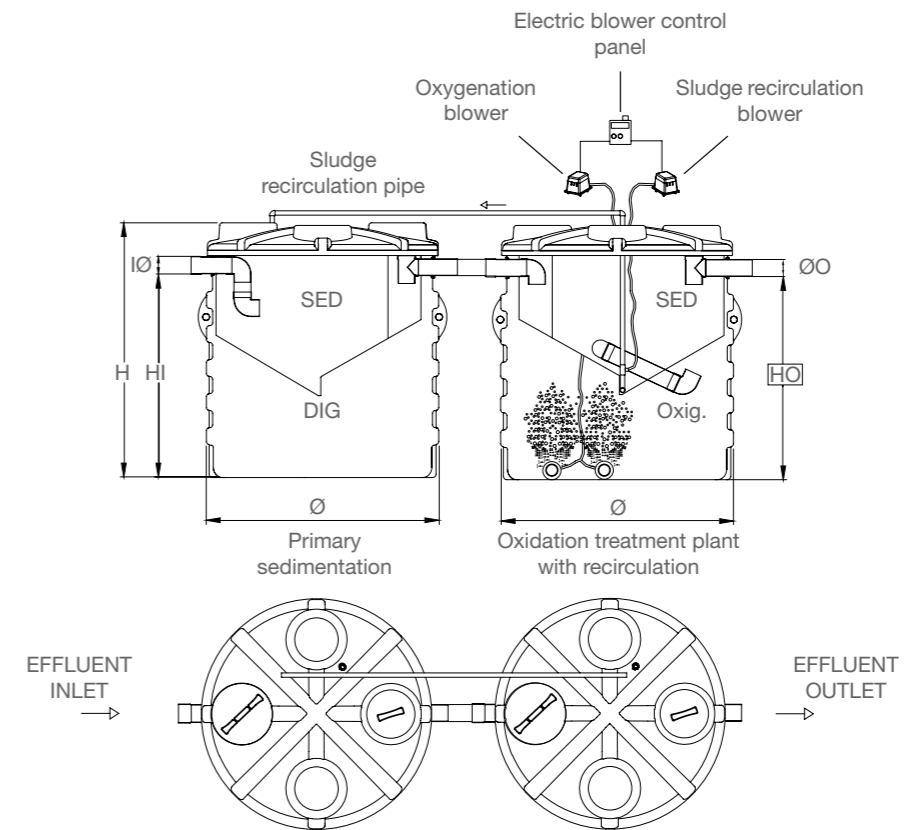

Item	Ø mm	H mm	HI mm	HO mm	Ø I/O mm	TANK 1		TANK 2		Hydraulic load l/d	Organic load gBOD ₅ /d	Blower power W	P.E.
						Sed. vol. l	Dig. Vol. l	Oxid. Vol. l	Final sed. vol. l				
DEPURO02ONE	1150	1221	933	913	110	260	628	628	260	0.4	0.12	60+40	2
DEPURO04ONE	1150	1779	1465	1445	110	384	1000	1000	1384	0.8	0.24	60+40	4
DEPURO07ONE	1710	1450	1000	980	125	629	1432	1432	2061	1.4	0.42	80+40	7
DEPURO10ONE	1710	1625	1240	1220	125	760	1765	1765	2525	2.0	0.6	80+40	10
DEPURO12ONE	1710	1855	1490	1470	125	965	2139	2139	3175	2.4	0.72	80+60	12
DEPURO15ONE	1710	2125	1710	1690	125	1085	2713	2713	3835	3.0	0.9	150+60	15
DEPURO20ONE	1950	2250	1660	1640	160	1210	3137	3137	4578	4.0	1.2	150+60	20
DEPURO25ONE	1950	2530	1970	1950	160	1322	3778	3778	5293	5.0	1.5	150+60	25
DEPURO32ONE	2250	2367	1850	1830	160	1460	5474	5474	6934	6.4	1.92	200+80	32
DEPURO40ONE	2250	2625	2070	2050	160	2020	5803	5803	7823	8.0	2.4	200+80	40

P.E.= population equivalent; Ø= diameter; H= height; HI= inlet pipe height; HO= outlet pipe height; Ø I/O= inlet/outlet pipe diameter; NS= limit flow rate (l/s).

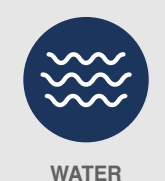

DEPURO PLUS+

[FIND OUT MORE](#)

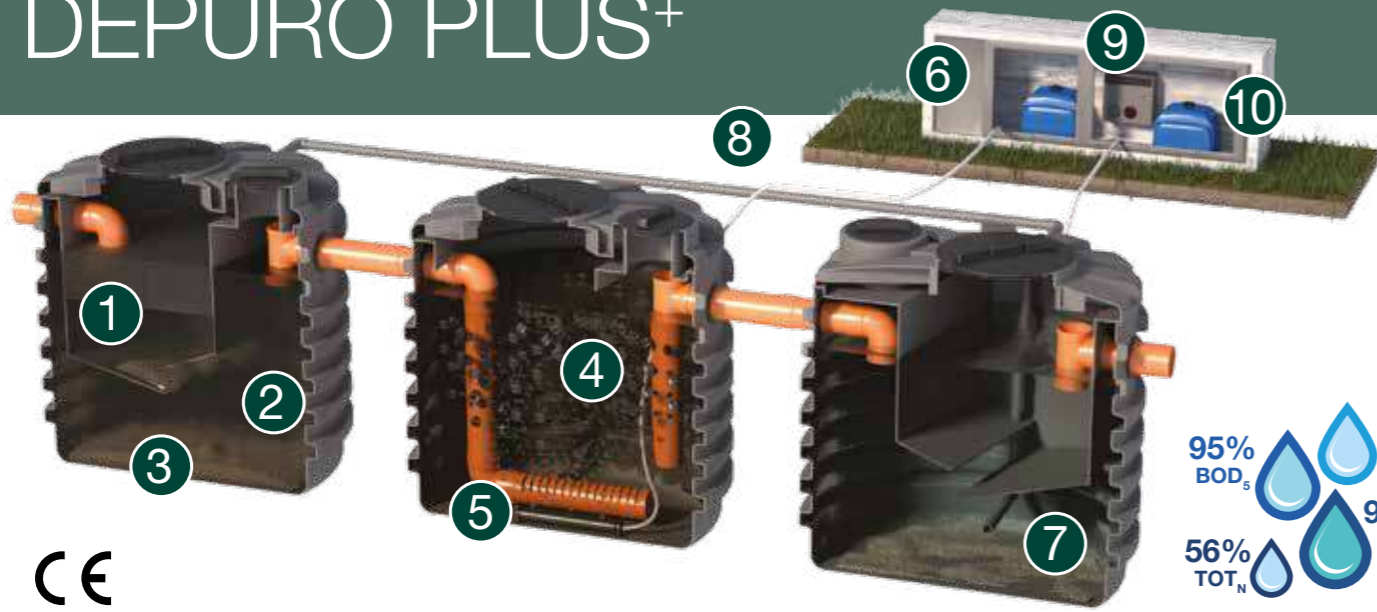

95% BOD₅ 92% COD
56% TOT_N 96% SS
DepuroPLUS treatment efficiency

- 1 SEDIMENTATION**
Sedimentation area for incoming solids.
- 2 DIGESTION**
Area into which the treated effluent flows for digestion.
- 3 SLUDGE**
Area in which the biological sludge responsible for treatment of the effluent is formed.
- 4 FILTER MEDIA**
Plastic filter media with a large surface area (> 450 m²/m³) that act as a support on which the aerobic bacterial that treat the effluent can develop.
- 5 PIPE DIFFUSERS**
micro-bubble air diffusers, included
- 6 OXYGENATION BLOWER**
Used to blow air into the treatment plant through the diffusers. Included.
- 7 FINAL SEDIMENTATION**
Stilling tank in which the surplus sludge sediments and returns once again to the primary sedimentation section.
- 8 SLUDGE RETURN**
Air-lift system to return the sludge that has settled in the primary sedimentation tank.
- 9 ELECTRIC PANEL**
Serving the blowers. Fitted with timer and buzzer/visual alarm (included).
- 10 RECIRCULATION BLOWER**
included.

TECHNICAL CHARACTERISTICS

DEPURO PLUS is a fully biological treatment system for domestic effluent and the like. It consists of three tanks: a primary tank for separation, digestion and sludge accumulation (primary sedimentation tank), an aerated adhered biomass treatment tank to oxidise the pollutants present in the effluent and a final sedimentation tank for the separation of the surplus sludge and the recirculation of it. All the tanks are made of polyethylene (PE) manufactured using rotational moulding technology.

USE

Primary and secondary treatment of domestic and assimilable sewage.

PRODUCT CERTIFICATION

UNI EN 12566/3: pre- and/or site assembled domestic waste water treatment systems.

INSTALLATION DIAGRAM

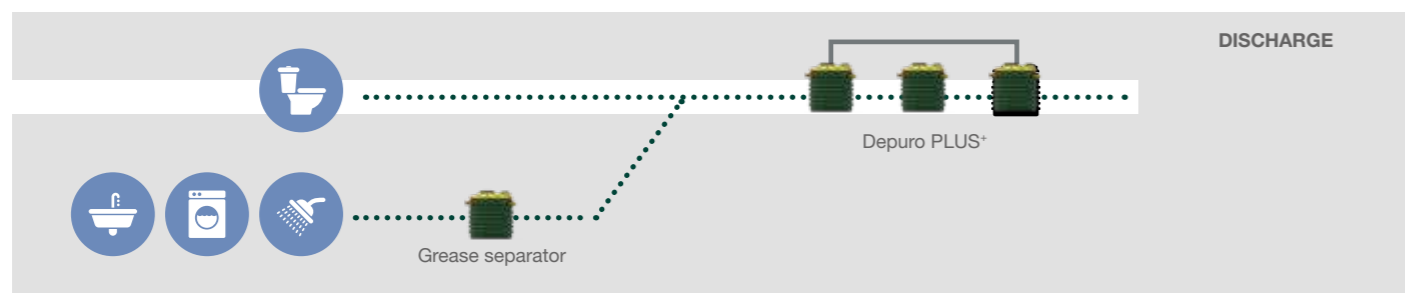

DEPURO PLUS+

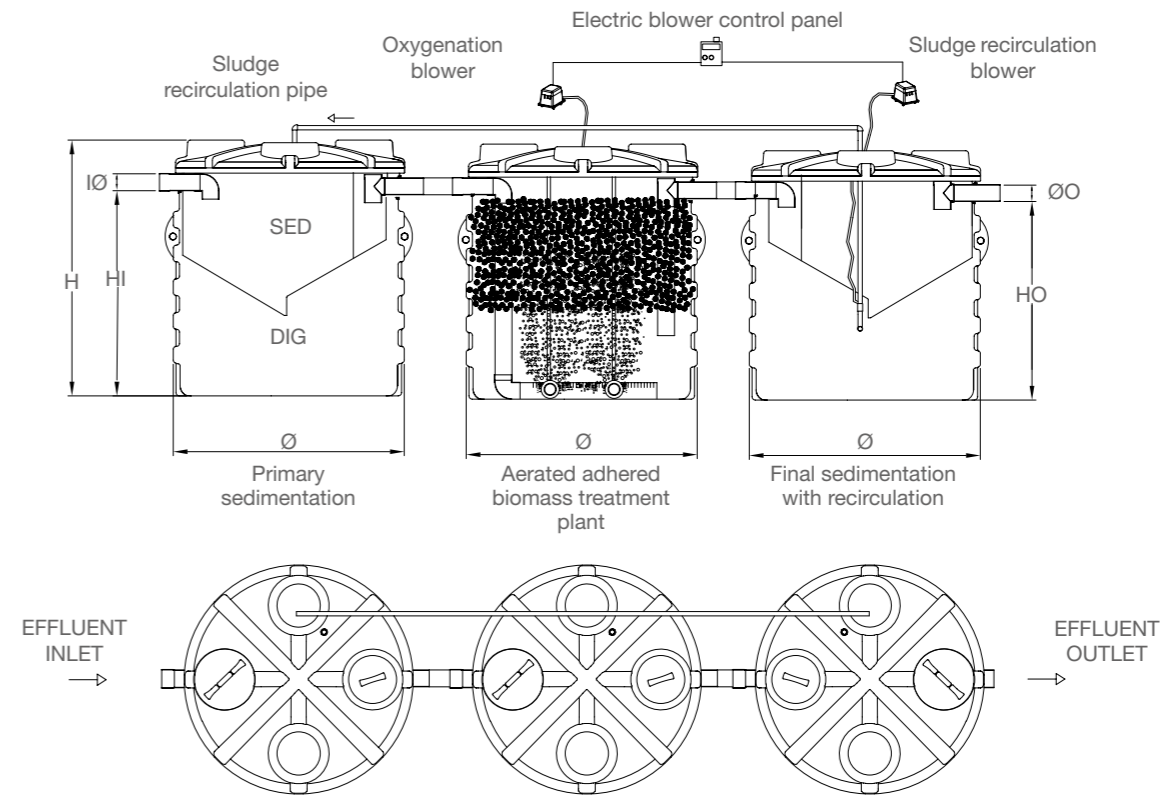

Item	Ø mm	H mm	HI mm	HO mm	Ø I/O mm	TANK 1			TANK 2			TANK 3			Hydraulic load l/d	Organic load gBOD ₅ /d	Blower power W	P.E.
						Sed. vol. l	Dig. Vol. l	Filt. Vol. l	Tot. Vol. l	Sed. vol. l	Dig. Vol. l	Filt. Vol. l	Tot. Vol. l	Sed. vol. l				
DEPURO03PLUS	1150	1221	933	913	110	260	628	628	888	600	180	61+31	3					
DEPURO05PLUS	1150	1779	1465	1445	110	384	1000	1000	1384	1000	300	61+31	5					
DEPURO10PLUS	1710	1350	1000	980	125	629	1432	1432	2061	2000	600	91+31	10					
DEPURO14PLUS	1710	1625	1240	1220	125	760	1765	1765	2525	2800	840	91+31	14					
DEPURO18PLUS	1710	1855	1490	1470	125	965	2139	2139	3175	3600	1080	91+61	18					
DEPURO23PLUS	1710	2125	1710	1690	125	1085	2713	2713	3835	4600	1380	152+61	23					
DEPURO28PLUS	1950	2250	1660	1640	160	1210	3137	3137	4578	5600	1680	152+61	28					
DEPURO35PLUS	1950	2530	1970	1950	160	1322	3778	3778	5293	7000	2100	152+61	35					
DEPURO40PLUS	2250	2367	1850	1830	160	1460	5474	5474	6934	8000	2400	186+91	40					
DEPURO45PLUS	2250	2625	2070	2050	160	2020	5803	5803	7823	9000	2700	186+91	45					

P.E.= population equivalent; Ø= diameter; H= height; HI= inlet pipe height; HO= outlet pipe height; Ø I/O= inlet/outlet pipe diameter; NS= limit flow rate (l/s).

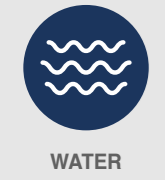



SEWAGE



WATER



UNDERGROUND INSTALLATION



p. 92
**STORMWATER
MANAGEMENT**

p. 128
**PLANTS
FOR CAR WASHES**

- TECHNICAL SECTION
- CHAMBERS
- LIFT STATIONS
- CHAMBERS
- PORTABLE TOILETS
- NON-STANDARD SOLUTIONS
- STORMWATER MANAGEMENT
- CAR WASH PLANTS
- DEPURATION
- DEPURBLOK
- SECONDARY TREATMENT PLANT
- TRICKLE FILTERS
- ACTIVATED SLUDGE PLANT
- BIOLOGICAL SEPTIC TANKS
- IMHOFF BIOLOGICAL TANKS
- GREASE SEPARATORS
- RAINFALL HARVESTING AND RE-USE SYSTEMS
- UNDERGROUND TANKS
- CONSTRUCTION SITE EQUIPMENT
- ACCESSORIES
- UNDERGROUND INSTALLATION

GRIT SEPARATORS

FIND OUT MORE



SEWAGE



WATER



UNDERGROUND INSTALLATION

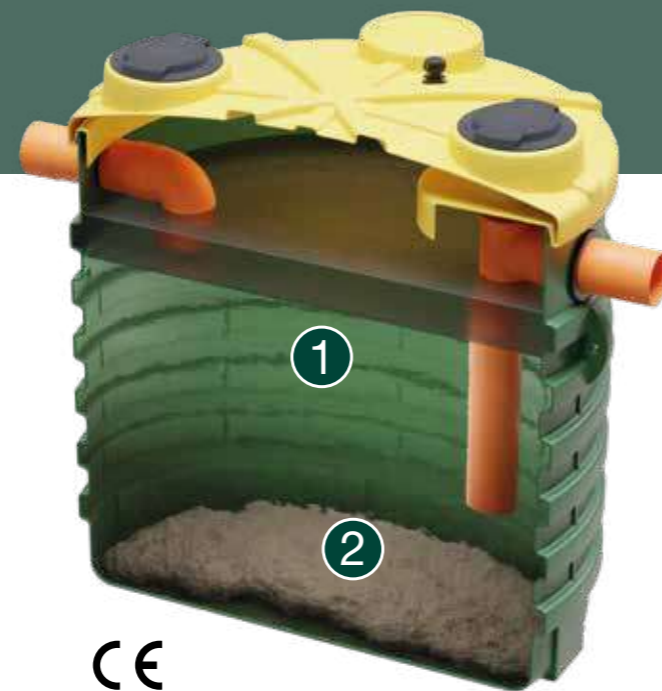

- 1 STILLING ZONE**
Zone through which the separated and treated effluent flows.
- 2 SEDIMENTS**
Area for the temporary accumulation of solids (stones, sand/grit, leaves, twigs, etc...).

CE
UNI EN 858-1



SPECIFICATIONS

TECHNICAL CHARACTERISTICS

Grit removal is a mechanical pretreatment that removes all substances of specific weight higher than water (stones, sand/grit, leaves, etc.) running off from covered and uncovered surfaces (roads, car parks, warehouse hardstandings, etc.) and wash areas. The grit separator is a settling tank in which the velocity of the fluid is reduced, allowing suspended solids to settle and accumulate at the bottom of the tank.

USE

Primary treatment of run-off and rainwater from exposed surfaces, hardstandings, car parks, industrial areas, service stations, etc.

REFERENCE STANDARDS

UNI EN 858-1 / UNI EN 858-2.

INSTALLATION DIAGRAM

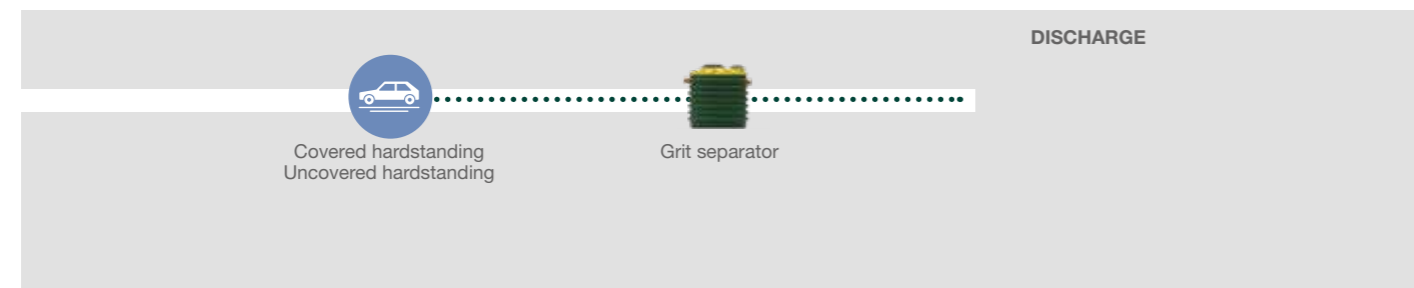

Item	Ø mm	H mm	HI mm	HO mm	Ø I/O mm	Cover 1	Cover 2	Extension 1 (optional)	Extension 2 (optional)	Useful Vol. l	NS l/s	Covered hardstanding m ²	Uncovered hardstanding m ²
XDS1000	1150	1221	870	850	125	CC400	CC200	PP45	PP30	889	3	1350	540
XDS1500	1150	1720	1350	1330	125	CC400	CC200	PP45	PP30	1254	5	2250	900
NDS2100	1350	1975	1530	1510	125	CC400	CC300	PP45	PP35	1932	6	2700	1080
NDS2600	1710	1450	970	950	160	CC400	CC300	PP45	PP35	1986	8	3600	1440
NDS3200	1710	1725	1210	1190	160	CC400	CC300	PP45	PP35	2450	10	4500	1800
NDS3800	1710	1955	1410	1390	200	CC400	CC300	PP45	PP35	3015	15	6750	2700
NDS4600	1710	2225	1670	1650	200	CC400	CC300	PP45	PP35	3675	20	9000	3600
NDS5400	1950	2250	1600	1580	250	CC400	CC400	PP45	PP45	4320	24	10800	4320
NDS6400	1950	2530	1870	1850	250	CC400	CC400	PP45	PP45	5035	28	12600	5040
NDS7000	2250	2367	1720	1700	315	CC400	CC400	PP45	PP45	6399	35	15750	6300
NDS9000	2250	2625	1970	1950	315	CC400	CC400	PP45	PP45	7288	40	18000	7200

Ø= diameter; H= height; HI= inlet pipe height; HO= outlet pipe height; Ø I/O= inlet/outlet pipe diameter; NS= limit flow rate (l/s).

OIL SEPARATORS

[FIND OUT MORE](#)



SEWAGE



WATER



UNDERGROUND INSTALLATION

GRAVITY OIL SEPARATORS

- 1 OIL SEPARATION AND ACCUMULATION AREA**
Stilling area in which floating substances such as oil, grease and any foam are separated from the effluent and accumulate on the surface.
- 2 SEDIMENTATION CHAMBER**
Conical sedimentation chamber that allows the flow to slow down, so that the heavy substances (sand, gravel, pieces of rubber and metal,...) can settle more easily and be carried into the sludge accumulation section beneath.
- 3 HEAVY SEDIMENT ACCUMULATION AREA**
Stilling zone in which heavy substances sediment and accumulate.
- 4 OUTLET PIPE**
It features a pipe that picks up the effluent at approximately the middle of the tank, i.e in the clearest area, so as to avoid the floating and sedimented material from exiting.



CE
UNI EN 858-1



SPECIFICATIONS

TECHNICAL CHARACTERISTICS

Static oil separator tanks are stilling tanks sized for a retention time of at least 15 minutes at maximum discharge flow. These oil separators are defined as class II according to UNI-EN 858-1 and consist of a sedimentation zone in which the lighter liquid (volumetric mass not exceeding 0.85 g/cm³) is separated from the inert materials: sludge, sand/grit and silt. Each model is designed with a light liquid storage capacity. The oil separators are sized according to a defined nominal flow, i.e. the maximum treatable flow according to the project specifications. This value is defined to allow a sufficient retention time of the treated effluent and on the basis of performance trials carried out on water and diesel oil mixes. The sizing of light liquid separators must take into account the nature and flow of the substances to treat, as well as any stormwater flows that could reach the plant, the volumetric mass of the light liquid and the presence of substances that could obstruct the separation, such as, for example, detergents. The design flow is calculated for light liquids of density less than 0.85 g/cm³ (diesel, petrol), in the absence of detergents and for surface run-off only.

USE

Treatment of surface drainage water from covered and open-air hardstandings, car parks, car showrooms, garages, ...

REFERENCE STANDARDS

UNI EN 858-1.

INSTALLATION DIAGRAM

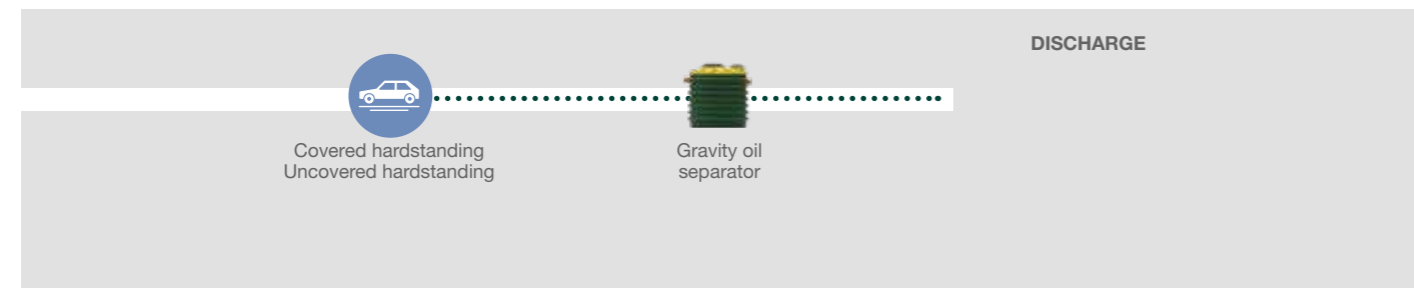

GRAVITY OIL SEPARATORS

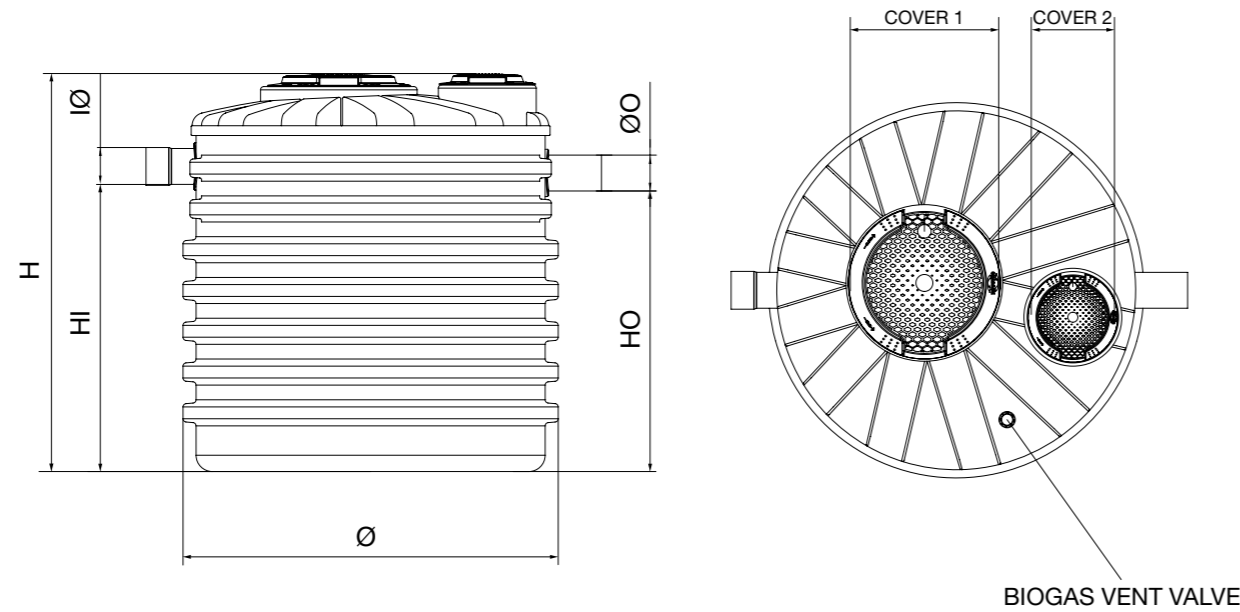

MODULAR GRAVITY OIL SEPARATORS

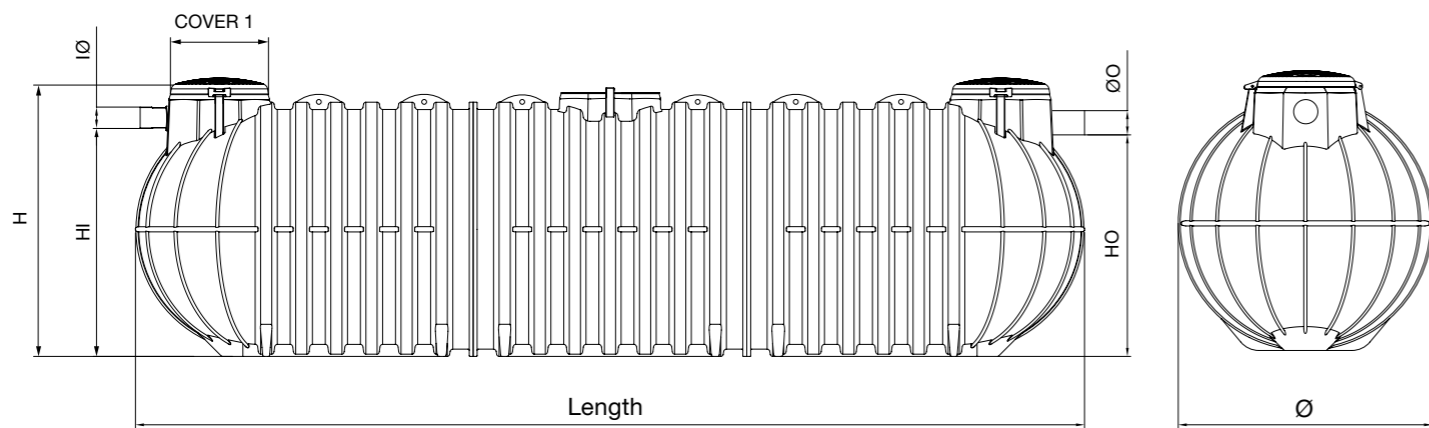

GRAVITY OIL SEPARATORS

Item	Mod.	Length mm	Width mm	Ø mm	H mm	HI mm	HO mm	Ø I/O mm	Useful Vol. l	Oil vol. l	Sed. vol. l	NS	Covered Hardstanding m ²	Covered Hardstanding Car Spaces	Uncovered Hardstanding m ²	Uncovered Hardstanding Car Spaces
NDO150		950	650	-	565	375	345	100	180	35	25	0.3	80	6	30	2
NDO200		1000	635	-	675	490	440	100	205	30	50	0.4	140	8	50	3
NDO300		1100	700	-	775	585	535	100	303	40	80	0.6	220	12	75	4
new NDO400		1150	750	-	890	695	645	100	409	55	110	0.8	290	16	100	5
XDO500		-	-	950	900	720	700	110	463	65	130	0.9	330	18	115	5
new NDO500		1400	900	-	750	560	530	100	510	75	140	1	360	20	125	6
XDO1000		-	-	1150	1221	930	910	110	850	22	62	2	700	40	300	12
XDO1500		-	-	1150	1779	1465	1445	110	1268	34	100	3	1000	55	450	18
new XDO1750		-	-	1350	1672	1285	1265	110	1645	40	115	3	1200	65	550	23
NDO2100		-	-	1350	1975	1540	1520	125	1950	45	130	5.5	1400	75	700	30
NDO2600		-	-	1710	1450	1000	980	125	2061	50	143	7	1700	88	900	40
NDO3200		-	-	1710	1725	1240	1220	125	2525	63	180	8.2	2500	120	1200	52
NDO3800		-	-	1710	1955	1525	1505	160	3175	80	220	9.5	3000	150	1500	60
NDO4600		-	-	1710	2225	1745	1725	160	3835	100	285	12	3850	195	1900	78
NDO5400		-	-	1950	2250	1700	1680	160	4578	120	340	14	4300	220	2100	85
NDO6400		-	-	1950	2530	2000	1980	160	5293	140	395	17	5100	250	2500	105
NDO7000		-	-	2250	2367	1885	1865	200	6934	225	657	20	6400	325	3000	130
NDO9000		-	-	2250	2625	2105	2085	200	7823	258	753	24	8400	430	4000	170
ITDO11000		4420	-	2100	2200	1860	1840	200	10135	340	920	28	10000	500	4800	200
ITDO13000		5010	-	2100	2200	1860	1840	200	12105	405	1090	35	12500	625	6100	260
ITDO15000		5620	-	2100	2200	1860	1840	200	14150	460	1280	40	14500	725	7000	300
ITDO18000		6680	-	2100	2200	1860	1840	200	16962	565	1520	45	16000	800	7800	330
ITDO20000		7270	-	2100	2200	1860	1840	250	18610	625	1700	50	18000	900	8800	375
ITDO22000		7880	-	2100	2200	1840	1820	250	20700	700	1850	56	20000	1000	9500	400
ITDO25000		8940	-	2100	2200	1860	1840	250	22985	770	2070	62	22000	1100	10600	450
ITDO28000		9530	-	2100	2200	1860	1840	250	25270	850	2300	68	23500	1180	11500	485
ITDO30000		10140	-	2100	2200	1840	1820	250	27250	910	2480	72	25000	1250	12000	500
ITDO33000		11200	-	2100	2200	1840	1820	315	29630	980	2650	75	27000	1350	13000	550
ITDO35000		11790	-	2100	2200	1840	1820	315	31710	1050	2830	80	29000	1450	14000	580
ITDO36000		12400	-	2100	2200	1840	1820	315	33800	1200	3050	85	30000	1500	14500	600
ITDO40000		13460	-	2100	2200	1840	1820	315	36290	1320	3260	100	34000	1700	16500	700

Ø= diameter; H= height; HI= inlet pipe height; HO= outlet pipe height; Ø I/O= inlet/outlet pipe diameter; NS= limit flow rate (l/s).



SEWAGE



WATER



UNDERGROUND INSTALLATION



GREASE SEPARATORS

IMHOFF BIOLOGICAL TANKS

BIOLOGICAL TANKS

BIOLOGICAL SEPTIC TANKS

ACTIVATED SLUDGE PLANT

TRICKLE FILTERS

SECONDARY TREATMENT PLANT

DEPURBLOK

DEPURO

STORMWATER MANAGEMENT

CAR WASH PLANTS

CHAMBERS

LIFT STATIONS

CHAMBERS

TECHNICAL SECTION

ABOVE-GROUND TANKS

ABOVE-GROUND MODULAR FIREFIGHTING TANKS

ACCESSORIES

UNDERGROUND TANKS

CONSTRUCTION SITE EQUIPMENT

OIL DISPOSAL UNIT

RAINWATER HARVESTING AND RE-USE SYSTEMS

PORTABLE TOILETS

NON-STANDARD SOLUTIONS

UNDERGROUND INSTALLATION

COALESCING FILTER OIL SEPARATORS

FIND OUT MORE

1 SEPARATION ZONE

Stilling zone in which floating substances such as oil, grease and any foam are separated from the effluent and accumulate on the surface, while the heavy substances (stones, grit, pieces of rubber and metal,...) settle on the bottom of the tank.

2 OIL ACCUMULATION AREA

Oils separated from the effluent accumulate on the surface.

3 HEAVY SEDIMENT ACCUMULATION AREA

The heavy materials separated from the effluent accumulate on the bottom of the tank.

4 COALESCING FILTER

Micro-bubble polyurethane filter inserted into a stainless steel grid, which can be extracted thanks to the presence of a base and guides, also made of stainless steel. The coalescing filter is able to join the fine particles of oil present in the effluent into larger drops big enough to migrate towards the surface, separating from the effluent.



CE
UNI EN 858-1

SPECIFICATIONS

TECHNICAL CHARACTERISTICS

Oil separators with coalescing filters allow improved performance to be obtained in removing light substances. The system makes use of a polyurethane sponge support on which the oil and hydrocarbon particles collect until their dimensions are such that enable them to settle away from the effluent by gravity. This treatment is recommended in the presence of particularly severe limitations on the discharged concentrations of mineral oils and hydrocarbons. It is advisable to install a grit separator upstream of the oil separator in order to prevent solid particles from clogging the filter meshes.

USE

Treatment of surface drainage water from covered and open-air hardstandings, car parks, car showrooms, garages, ...

REFERENCE STANDARDS

UNI EN 858-1.

PRODUCT CERTIFICATION

UNI EN 858-1 Separation systems for light liquids (for example diesel and petrol). Part 1 - Principles of design, performance and product testing, marking and quality control.

INSTALLATION DIAGRAM

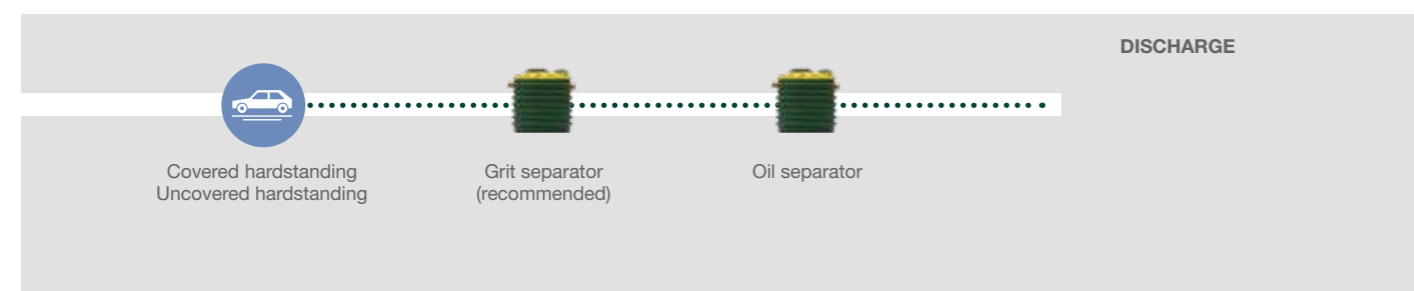

AUTOMATIC FLOAT VALVE ON REQUEST



TECHNICAL CHARACTERISTICS

Float valve in plastic calibrated for light liquids of density > 0.85 g/cm³.

USE

When installed inside coalescing filter oil separators it allows the outlet pipe to be closed automatically when the maximum oil containment level is reached.

Item
KITOTTG

OIL ALARM KIT ON REQUEST

MATERIAL

Type-approved ATEX electric float switch in blow moulded polyethylene providing a perfect seal, visual and audible alarm signal, complete with wall-mounted unit.

FUNCTION

Installed inside an oil separator, the electric float switch has a unique characteristic that enables it to float on the water and not on the hydrocarbons. This allows a signal to be generated when a certain level of oil is reached inside the tank, indicating that cleaning operations need to be carried out.

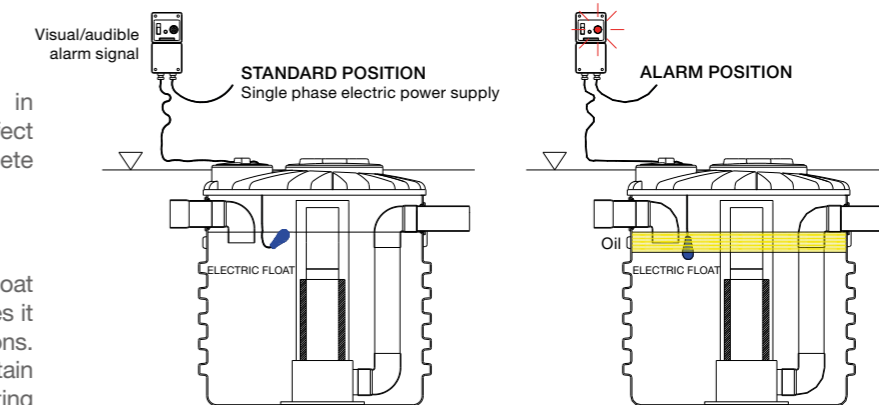

Item
KTAOIL

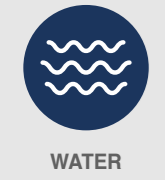

COALESCING FILTER OIL SEPARATORS

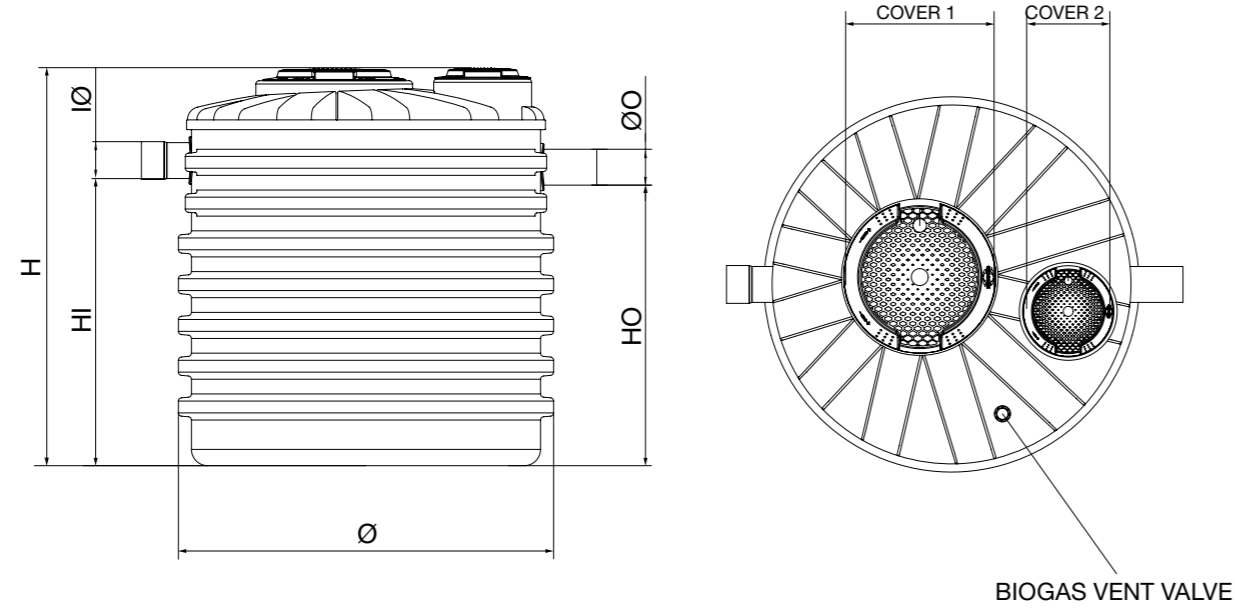

Item	Mod.	Ø mm	H mm	HI mm	HO mm	Ø I/O mm	Useful Vol. l	Oil vol. l	NS	Covered Hardstanding m ²	Covered Hardstanding No. Car Spaces	Uncovered Hardstanding m ²	Uncovered Hardstanding No. Car Spaces
XDOFC1000 1.5 l/s		1150	1220	930	910	125	888	27	1.5	675	54	270	22
XDOFC1500 2 l/s		1150	1779	1460	1440	125	1384	35	2	900	72	360	30
XDOFC1000 3 l/s		1150	1220	930	1440	125	888	53	3	1350	108	540	43
XDOFC1500 4 l/s		1150	1779	1460	1340	125	1384	70	4	1800	144	720	58
NDOFC2100 6 l/s		1350	1975	1540	1520	125	1950	130	6	2700	200	1000	80
NDOFC2600 7.5 l/s		1710	1450	970	950	160	2061	152	7.5	3375	270	1350	110
NDOFC3200 10 l/s		1710	1725	1220	1200	160	2525	176	10	4500	360	1800	147
NDOFC3800 15 l/s		1710	1955	1430	1410	200	3175	225	15	6750	540	2700	220
NDOFC4600 20 l/s		1710	2225	1650	1630	200	3835	300	20	9000	720	3600	294
NDOFC5400 25 l/s		1950	2250	1600	1580	250	4347	375	25	11250	900	4500	367
NDOFC6400 30 l/s		1950	2530	1890	1870	250	5100	450	30	13500	1080	5400	440
NDOFC7000 35 l/s		2250	2367	1720	1700	315	6934	525	35	15750	1260	6300	515
NDOFC7000 40 l/s		2250	2367	1720	1700	315	6934	600	40	18000	1440	7200	588
NDOFC9000 50 l/s		2250	2625	1950	1930	315	7823	750	50	22500	1800	9000	734

Ø= diameter; H= height; HI= inlet pipe height; HO= outlet pipe height; Ø I/O= inlet/outlet pipe diameter; NS= limit flow rate (l/s).

NOTES

HORIZONTAL OIL SEPARATOR WITH COALESCING FILTER

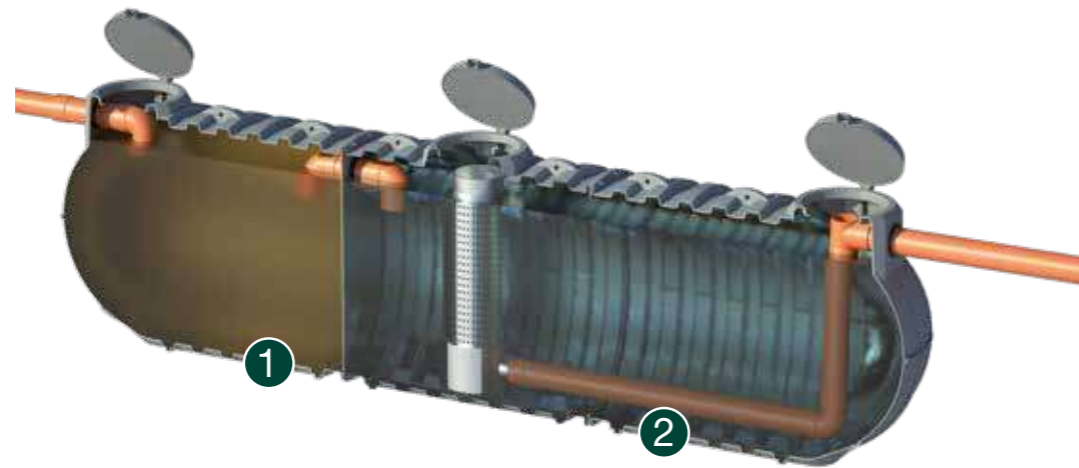

CE
UNI EN 858-1

1 GRIT SEPARATION SECTION

Sedimentation tank on the bottom of which heavy substances (stones, sand, rubber and metal residue, etc.) are deposited. At the same time, light-weight coarser material (drops of oil, hydrocarbons and any foam) accumulate on the surface.

2 OIL SEPARATOR SECTION WITH COALESCING FILTER

Thanks to the coalescing filter made of polyurethane material with fine microbubbles, installed inside a stainless steel cage, which is removable thanks to the presence of a stainless steel base and guides, the fine oil particles present in the waste water are combined into larger drops, separated from the water and directed to the surface.

SPECIFICATIONS

TECHNICAL CHARACTERISTICS

The system is used to treat stormwater run-off from impermeable surfaces up to 27,000 m² used for transit or parking in industrial areas, residential zones and service stations subject to possible pollution from mineral oils, hydrocarbons, sand/grit and inert materials. The stormwater run-off treatment system makes use of the action of a grit and hydrocarbon separator capable of treating flows of up to 150 l/s. Run-off from impermeable transit areas must be carried to the treatment system. The treatment tanks receive the flow appertaining to first 5 mm of rain falling over a 15-minute period. For higher flows, the by-pass is activated, sending the excess water to the stormwater storage tanks. The treatment system consists of a grit separation section and a hydrocarbons separation section with coalescing filter, to guarantee that the waste water leaving the plant have characteristics suited to release into a surface watercourse (Attachment 5, Table 3, Leg. Dec. 152/2006).

The system is effective for the following parameters:

- Sedimentable solids.
- Total hydrocarbons and other light liquids that have not been emulsified of specific weight up to 0.85 g/cm³.
- Unless otherwise specified, the peak flows in m³/h for each model must be less than the limits indicated on the technical data sheet.
- Unless otherwise specified the surface area (m²) of the area to treat for each model must be smaller than or equal to the limits indicated on the technical data sheet.
- For anything not specifically indicated, refer to the design data on the technical data sheet.

USE

Treatment of run-off from open-air courtyards, car parks, roads, service stations, warehouses,...

PRODUCT CERTIFICATION

UNI EN 858-1 Separation systems for light liquids (e.g. oil and petrol). Part 1 - Principles of design, characteristics and product testing, marking and quality control.

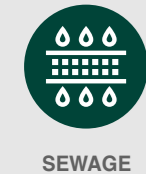

SEWAGE



WATER

UNDERGROUND
INSTALLATION

HORIZONTAL OIL SEPARATOR WITH COALESCING FILTER

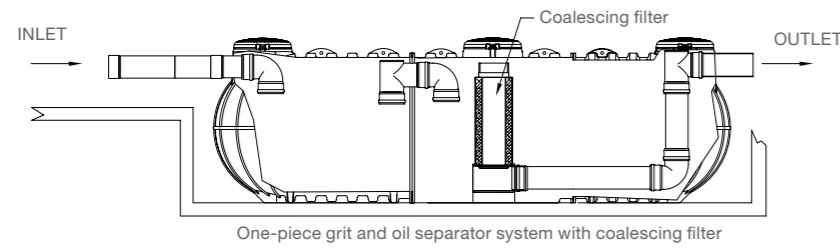

Item	Flow rate l/s	Uncovered surface area m ²	One-piece grit and oil separator				
			L x w x H mm	IØ-ØØ mm	Total useful volume l	Oil collection volume l	Grit collection volume l
ITDSFC20000	60	10800	7270x2100x2200	315-315	18500	800	5500

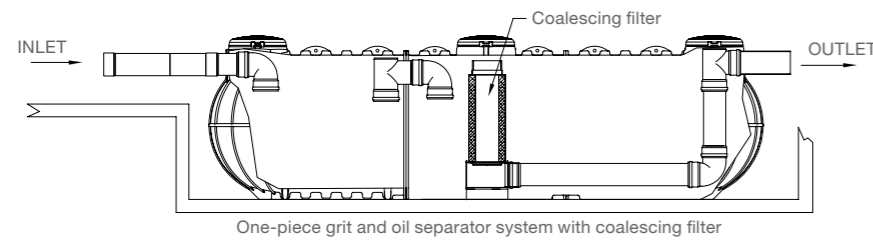

Item	Flow rate l/s	Uncovered surface area m ²	One-piece grit and oil separator				
			L x w x H mm	IØ-ØØ mm	Total useful volume l	Oil collection volume l	Grit collection volume l
ITDSFC22000	65	11500	7880x2100x2200	315-315	20500	1000	6700

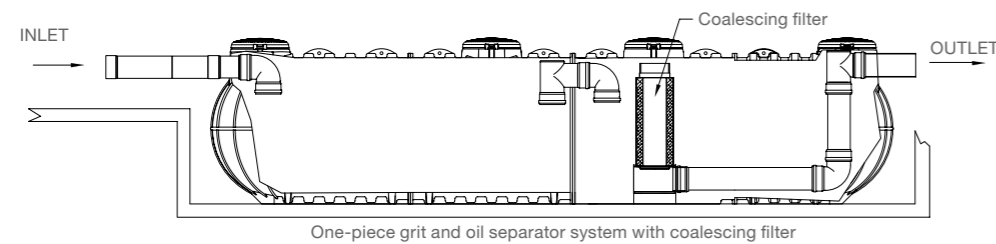

Item	Flow rate l/s	Uncovered surface area m ²	One-piece grit and oil separator				
			L x w x H mm	IØ-ØØ mm	Total useful volume l	Oil collection volume l	Grit collection volume l
ITDSFC28000	80	14400	9530x2100x2200	315-315	25500	1200	7800

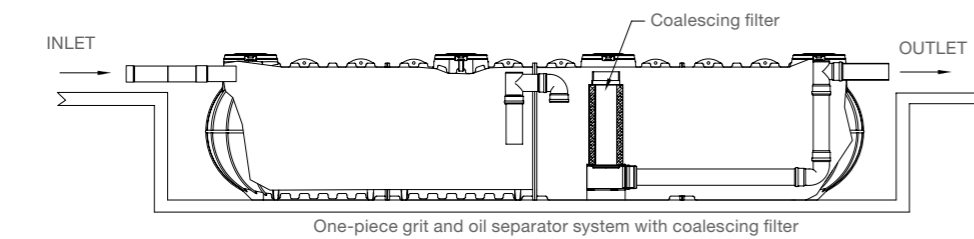

Item	Flow rate l/s	Uncovered surface area m ²	One-piece grit and oil separator				
			L x w x H mm	IØ-ØØ mm	Total useful volume l	Oil collection volume l	Grit collection volume l
ITDSFC30000	85	15300	10140x2100x2200	315-315	27000	13000	8600

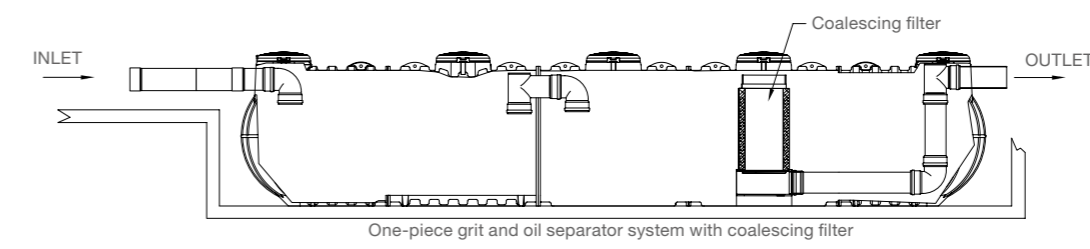

Item	Flow rate l/s	Uncovered surface area m ²	One-piece grit and oil separator				
			L x w x H mm	IØ-ØØ mm	Total useful volume l	Oil collection volume l	Grit collection volume l
ITDSFC33000	90	16200	11200x2100x2200	315-315	29500	1400	9200

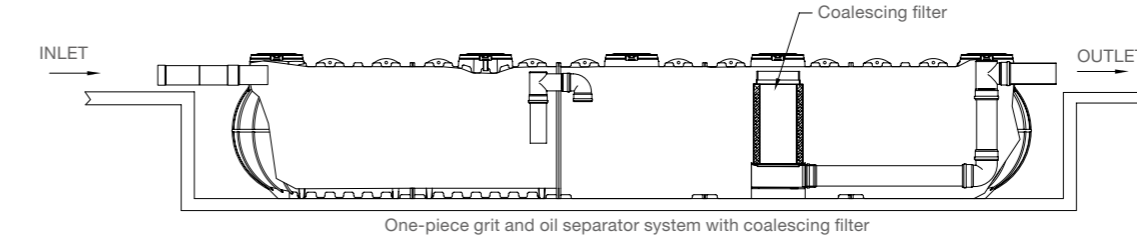

Item	Flow rate l/s	Uncovered surface area m ²	One-piece grit and oil separator				
			L x w x H mm	IØ-ØØ mm	Total useful volume l	Oil collection volume l	Grit collection volume l
ITDSFC36000	100	18000	12400x2100x2200	315-315	33500	1550	10000

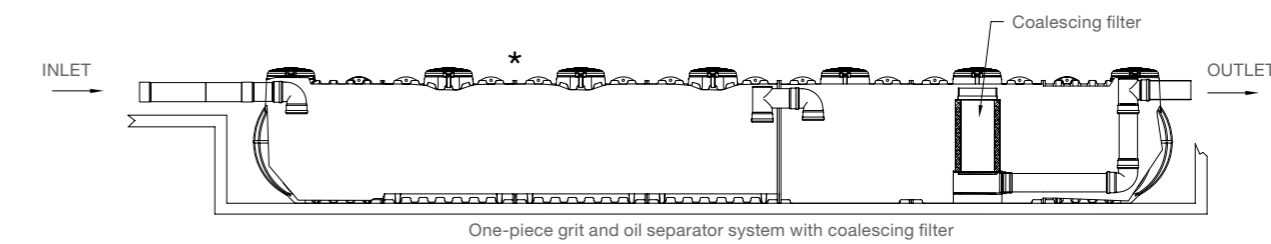

Item	Flow rate l/s	Uncovered surface area m ²	One-piece grit and oil separator				
			L x w x H mm	IØ-ØØ mm	Total useful volume l	Oil collection volume l	Grit collection volume l
ITDSFC40000	110	19800	13460x2100x2200	315-315	36000	1700	11000

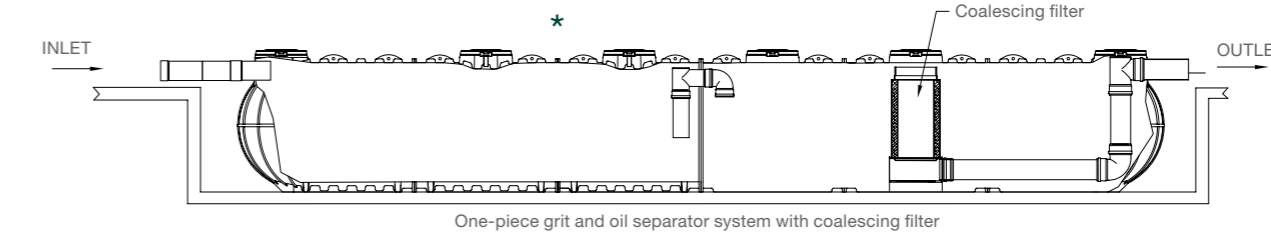

Item	Flow rate l/s	Uncovered surface area m ²	One-piece grit and oil separator				
			L x w x H mm	IØ-ØØ mm	Total useful volume l	Oil collection volume l	Grit collection volume l
ITDSFC45000	120	22000	14660x2100x2200	315-315	40000	1850	13000



SEWAGE



WATER



UNDERGROUND INSTALLATION



GREASE SEPARATORS
IMHOFF BIOLOGICAL TANKS
BIOLOGICAL SEPTIC TANKS
ACTIVATED SLUDGE PLANT
TRICKLE FILTERS
SECONDARY TREATMENT PLANT
DEPURBLOK
DEPURO
STORMWATER MANAGEMENT
CAR WASH PLANTS
LIFT STATIONS
CHAMBERS
CHAMBERS
TECHNICAL SECTION
NON-STANDARD SOLUTIONS

ABOVE-GROUND TANKS
ABOVE-GROUND MODULAR FIREFIGHTING TANKS
ACCESSORIES
UNDERGROUND TANKS
CONSTRUCTION SITE EQUIPMENT
OIL DISPOSAL UNIT
PORTABLE TOILETS
RAINWATER HARVESTING AND RE-USE SYSTEMS

COALESCING OIL SEPARATOR WITH INTEGRATED BY-PASS

[FIND OUT MORE](#)

- 1 SEPARATION ZONE**
Stilling zone in which floating substances such as oil, grease and any foam are separated from the effluent and accumulate on the surface, while the heavy substances (stones, grit, pieces of rubber and metal,...) settle on the bottom of the tank.
- 2 OIL ACCUMULATION AREA**
Oils separated from the effluent accumulate on the surface.
- 3 HEAVY SEDIMENT ACCUMULATION AREA**
The heavy materials separated from the effluent accumulate on the bottom of the tank.
- 4 COALESCING FILTER**
Micro-bubble polyurethane filter inserted into a stainless steel grid, which can be extracted thanks to the presence of a base and guides, also made of stainless steel. The coalescing filter is able to join the fine particles of oil present in the effluent into larger drops big enough to migrate towards the surface, separating from the effluent.
- 5 INTEGRATED BYPASS**
Activated automatically when the flow rate of the effluent at the inlet exceeds the design flow. The excess flow is sent directly to the outlet in order to prevent overloading the coalescing filter.
- 6 AUTOMATIC FLOAT VALVE**
Float valve in plastic that allows the outlet pipe to be shut-off automatically when the maximum oil containment level has been reached.

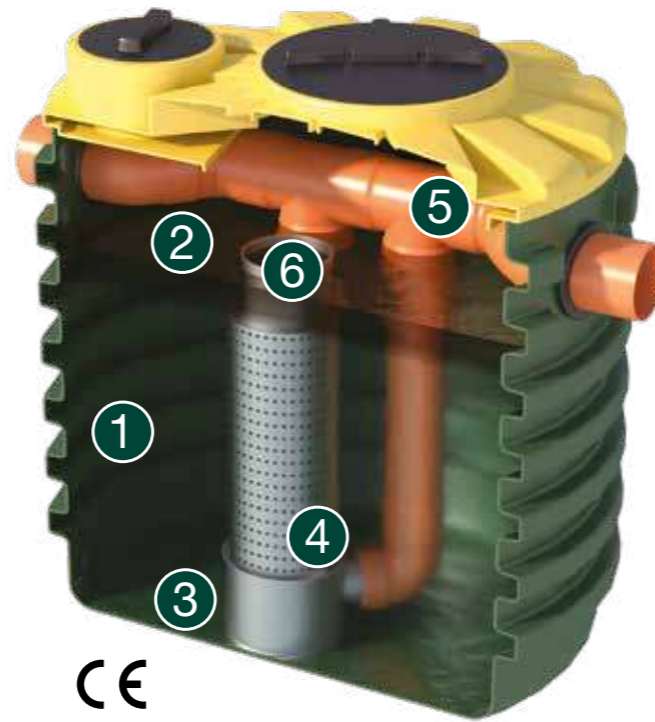

CE
UNI EN 858-1

SPECIFICATIONS

TECHNICAL CHARACTERISTICS

Oil separators with coalescing filters guarantee improved performance in removing light substances. The system makes use of a polyurethane sponge support, enclosed in a stainless steel cage, on which the oil and hydrocarbon particles collect until their dimensions are such that enable them to settle away from the effluent by gravity. This treatment is recommended in the presence of particularly severe limitations on the concentrations of mineral oils and hydrocarbons at the discharge point. It is advisable to install a grit separator upstream of the oil separator in order to prevent solid particles from clogging the filter mesh. The oil separator is equipped with an internal bypass manifold that is activated automatically when the flow rate of the effluent at the inlet exceeds the design flow. The excess flow is sent directly to the outlet in order to prevent overloading the coalescing filter. The actual flow treated is equal to 10% of the maximum inlet flow.

USE

Treatment of surface drainage water from covered and open-air hardstandings, car parks, car showrooms, garages, ...

REFERENCE STANDARDS

UNI-EN 858-1.

Item	Ø mm	H mm	HI mm	HO mm	Ø I/O mm	Useful vol. l	NSx5	Max. F.R. l/s	NSx10	Uncovered hardstanding m ²
XDOFC1000BPD160	1150	1221	830	820	160	900	3-15	15	-	540
XDOFC1000BPD200	1150	1221	810	800	200	900	4-20	20	4-40	720
XDOFC1500BPD200	1150	1779	1210	1200	200	1400	5-25	25	-	850
new XDOFC1750BPD250	1350	1672	1105	1095	250	1400	6-30	30	6-60	1000
NDOFC2100BPD250	1350	1975	1400	1390	250	2000	7-35	35	7-70	6300
NDOFC2600BPD250	1710	1450	860	850	250	2400	8-40	40	-	7200
NDOFC3200BPD315	1710	1725	1070	1060	315	3000	-	-	8-80	9000
NDOFC3800BPD315	1710	1955	1270	1260	315	3600	10-50	50	10-100	10800
NDOFC4600BPD315	1710	2225	1560	1550	315	4200	12-60	60	12-120	13500
NDOFC4600BPD400	1710	2225	1470	1460	400	4200	15-75	75	15-150	10800
NDOFC5400BPD400	1950	2250	1450	1440	400	5200	20-100	100	20-200	18000
NDOFC6400BPD400	1950	2530	1710	1700	400	5600	25-125	125	25-250	22500
NDOFC7000BPD400	2250	2367	1610	1600	400	6800	32-160	160	-	28800
NDOFC9000BDP400	2250	2625	1950	1940	400	8800	40-200	200	-	8000

Ø= diameter; H= height; HI= inlet pipe height; HO= outlet pipe height; Ø I/O= inlet/outlet pipe diameter; NS= flow rate in l/s treated - maximum inlet flow rate; MAX. F.R.= limit flow rate (l/s).

SEWAGE TREATMENT EFFICIENCY

The coalescing oil separator with integrated bypass (installed as shown in the diagram at page 110) ensures that the concentrations of the final effluent are:

≤5 mg/l
Total Hydrocarbons

≤80 mg/l
SS

These parameters are respected if the inlet wastewater have the following characteristics (typical concentrations of surface drainage water):

≤50 mg/l
COD

≤400 mg/l
SS

INSTALLATION DIAGRAM

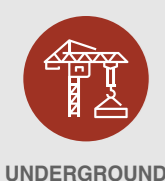
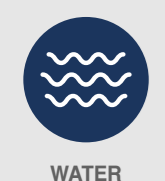
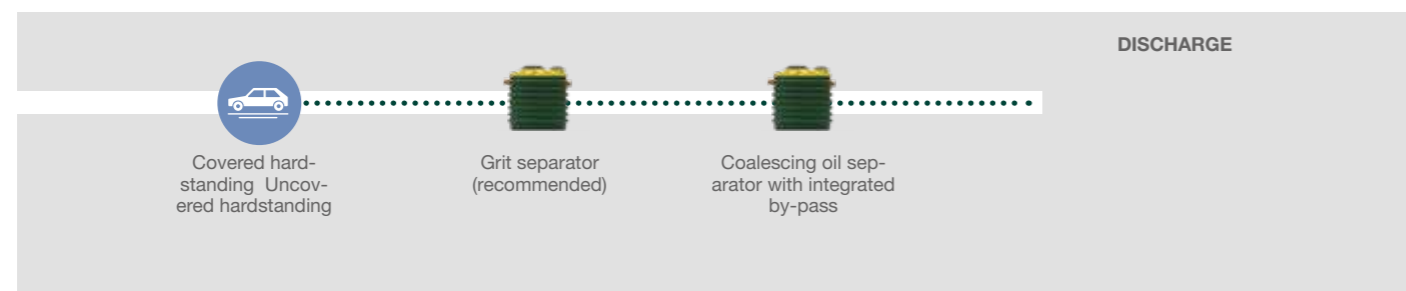

HORIZONTAL OIL SEPARATOR WITH COALESCING FILTER AND EXTERNAL BYPASS

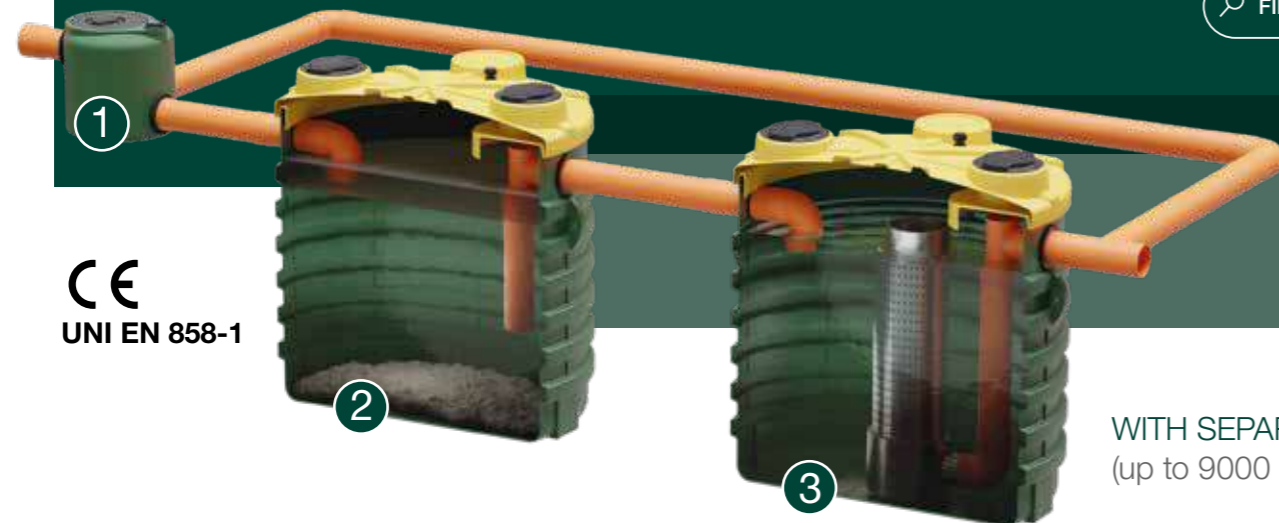
[FIND OUT MORE](#)

CE
UNI EN 858-1

WITH SEPARATE TANKS
(up to 9000 sq.m. - 50 l/s)

ONE-PIECE
from 10800 m² - 60 l/s
to 27000 m² - 150 l/s

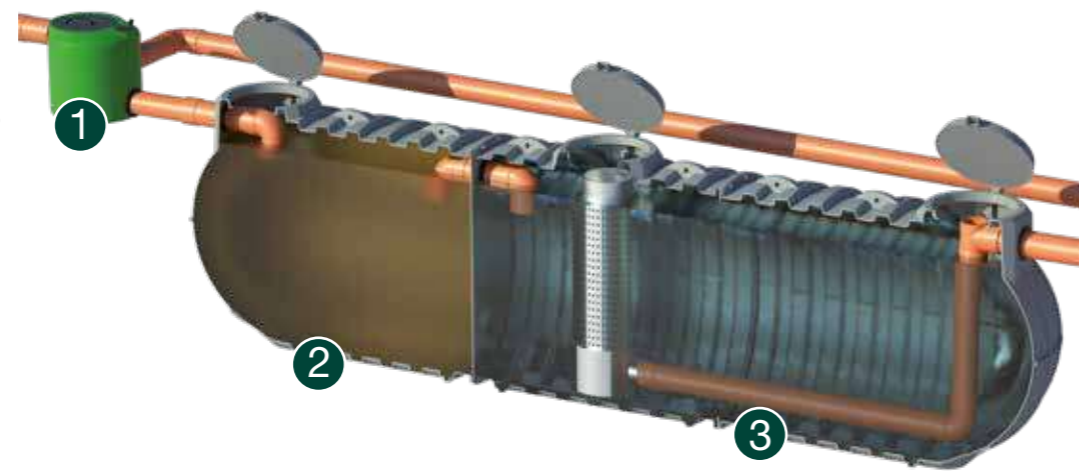

1 FLOW SPLITTING CHAMBER

This carries the collected rainwater from the hardstanding to the grit separator and oil separator system. When the incoming flow exceeds the design specifications, part of the incoming water is carried directly to the end tank via the by-pass pipe.

2 GRIT SEPARATOR SECTION

Stilling tank in which the heavy substances (stones, grit, pieces of rubber and metal,...) settle and accumulate on the bottom of the tank. At the same time the larger light components (drops of oil, hydrocarbons and any foam) accumulate on the surface.

3 OIL SEPARATOR SECTION WITH COALESCING FILTER

Thanks to the fine micro-bubble polyurethane coalescing filter inserted into a stainless steel grid, which can be extracted thanks to the presence of a base and guides, also made of stainless steel, the fine particles of oil and hydrocarbons join together to form drops that are large enough to migrate towards the surface, separating from the effluent.



SPECIFICATIONS

TECHNICAL CHARACTERISTICS

The plant allows the continuous treatment of stormwater run-off from impermeable surfaces up to 27000 m² used for transit or parking in industrial areas, residential zones and service stations subject to possible pollution from mineral oils, hydrocarbons, sand/grit and inert materials. The stormwater run-off treatment system makes use of the action of a grit and oil separator in continuous operation capable of treating flows of up to 150 l/s. Run-off from impermeable transit areas must be carried to the treatment system. For higher flow rates the by-pass is activated, sending the excess water to the stormwater storage tanks. The treatment plant consists of a grit separator and a coalescing filter type oil separator, thus ensuring that the final effluent possesses the appropriate characteristics for discharge to a body of surface water.

The plant is effective for the following parameters:

- Sedimentable solids.
- Total hydrocarbons and other light liquids that have not been emulsified of specific weight up to 0.85 g/cm³.
- Unless otherwise specified, the peak flows in m³/h for each single model must be less than that indicated on the technical data sheet.
- Unless otherwise specified the surface area (m²) of the hardstanding to treat for each single model must be less than or equal to the limits indicated on the technical data sheet.
- For anything not specifically indicated, refer to the design data specified on the technical data sheet.

USE

Treatment of surface drainage water from open-air hardstandings, car parks, roads, service stations, warehouses,...

REFERENCE STANDARDS

Standard UNI EN 858-1 (oil separator).



SEWAGE



WATER

UNDERGROUND
INSTALLATION

HORIZONTAL OIL SEPARATOR

WITH COALESCING FILTER AND EXTERNAL BYPASS

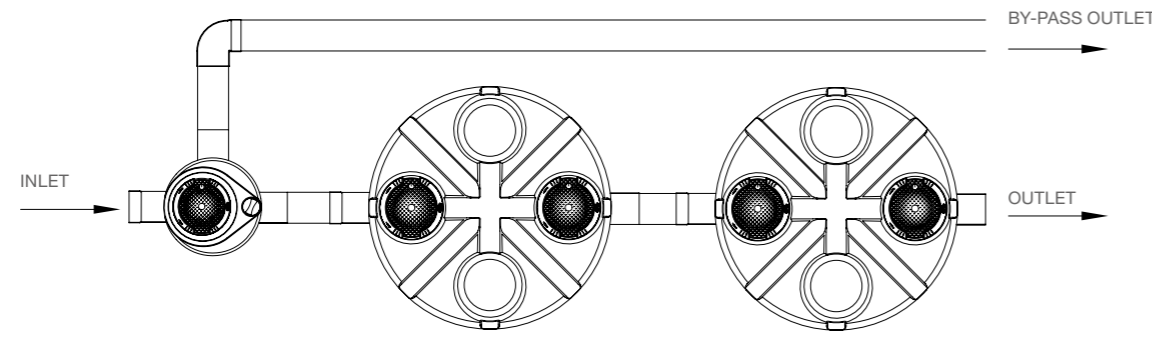
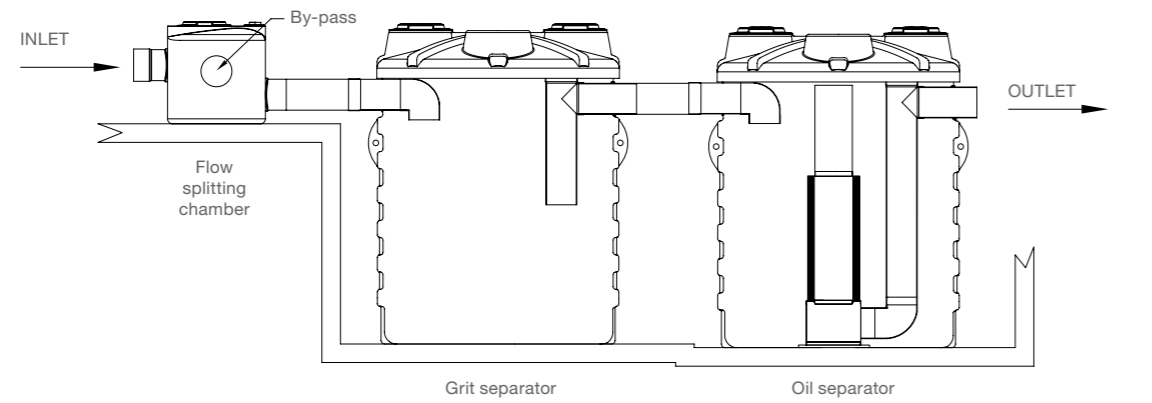

Item	Flow rate l/s	Uncovered surf. sq.m.	Overall useful vol. l	Oil collection vol. l	Sand collection volume l	Flow splitting chamber			Grit separator			Oil separator		
						Model	ØxH mm	Pipes Ø mm	Model	ØxH mm	Pipes Ø mm	Model	ØxH mm	Pipes Ø mm
IPC270	1.5	270	1700	27	150	PSC011212IPC	580x660	125	XDS1000	1150x1221	125	XDOFC1000 1.5LS	1150x1220	125
IPC360	2	360	2118	35	200	PSC011212IPC	580x660	125	XDS1000	1150x1221	125	XDOFC1500 2LS	1150x1779	125
IPC540	3	540	2118	53	300	PSC011212IPC	580x660	125	XDS1500	1150x1720	125	XDOFC1000 3LS	1150x1220	125
IPC720	4	720	2536	70	400	PSC011212IPC	580x660	125	XDS1500	1150x1720	125	XDOFC1500 4LS	1150x1779	125
IPC1000	6	1000	3900	130	700	PSC011212IPP	580x660	125	NDS2100	1350x1975	125	NDOFC2100 6LS	1350x1975	125
IPC1350	7.5	1350	4122	152	860	PSC051616IPC	790x790	160	NDS2600	1710x1450	160	NDOFC2600 7.5LS	1710x1450	160
IPC1800	10	1800	5050	176	1000	PSC051616IPC	790x790	160	NDS3200	1710x1725	160	NDOFC3200 10LS	1710x1725	160
IPC2700	15	2700	6208	225	1500	PSC052020IPC	790x790	200	NDS3800	1710x1955	200	NDOFC3800 15LS	1710x1955	200
IPC3600	20	3600	7596	300	2000	PSC052020IPC	790x790	200	NDS4600	1710x2225	200	NDOFC4600 20LS	1710x2225	200
IPC4500	25	4500	8694	375	2500	PSC052525IPC	790x790	250	NDS5400	1950x2250	250	NDOFC5400 25LS	1950x2250	250
IPC5400	30	5400	10200	450	3000	PSC052525IPC	790x790	250	NDS6400	1950x2530	250	NDOFC6400 30LS	1950x2530	250
IPC6300	35	6300	13868	525	3500	PSC103131IPC	1116x1140	315	NDS7000	2250x2367	315	NDOFC7000 35LS	2250x2367	315
IPC7200	40	7200	14757	600	4000	PSC103131IPC	1116x1140	315	NDS9000	2250x2625	315	NDOFC7000 40LS	2250x2367	315
IPC9000	50	9000	15357	750	5000	PSC103131IPC	1116x1140	315	NDS9000	2250x2625	315	NDOFC9000 50LS	2250x2625	315

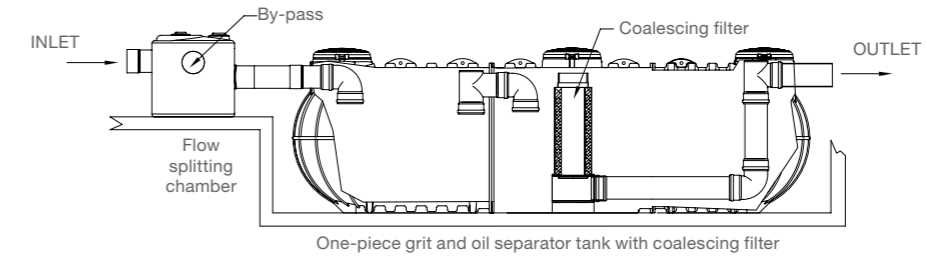

Item	Flow rate l/s	Uncovered area sq.m	Flow splitting chamber			Grit/oil separator				
			Model	Ø x H mm	IO-ØØ-BpØ mm	L x w x H mm	IO-ØØ mm	Useful volume l	Oil collection volume l	Sand collection volume l
ITIPC9500	60	10800	PSC103131IPC	1160x1140	315-315-315	7270x2100x2200	315-315	18500	800	5500

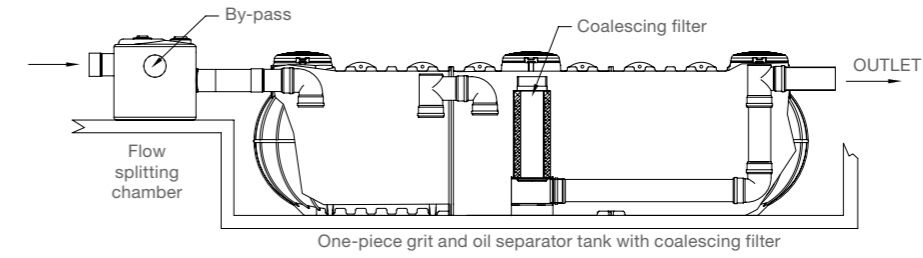

Item	Flow rate l/s	Uncovered area sq.m	Flow splitting chamber			Grit/oil separator				
			Model	Ø x H mm	IO-ØØ-BpØ mm	L x w x H mm	IO-ØØ mm	Useful volume l	Oil collection volume l	Sand collection volume l **
ITIPC10000	65	11500	PSC103131IPC	1160x1140	315-315-315	7880x2100x2200	315-315	20500	1000	6700

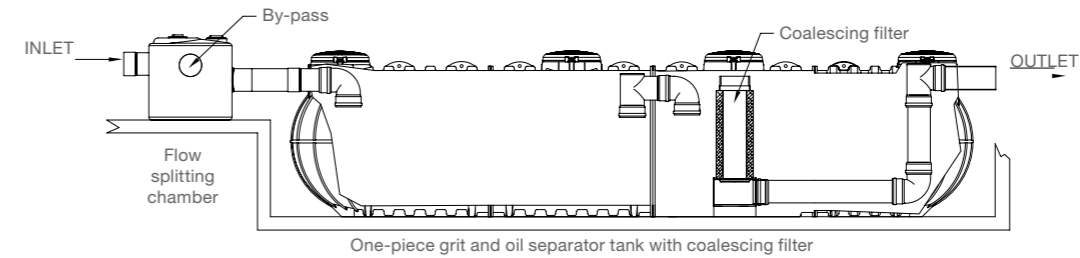

Item	Flow rate l/s	Uncovered area sq.m	Flow splitting chamber			Grit/oil separator				
			Model	Ø x H mm	IO-ØØ-BpØ mm	L x w x H mm	IO-ØØ mm	Useful volume l	Oil collection volume l	Sand collection volume l **
ITIPC11500	80	14400	PSC103131IPC	1160x1140	315-315-315	9530x2100x 2200	315-315	25500	1200	7800

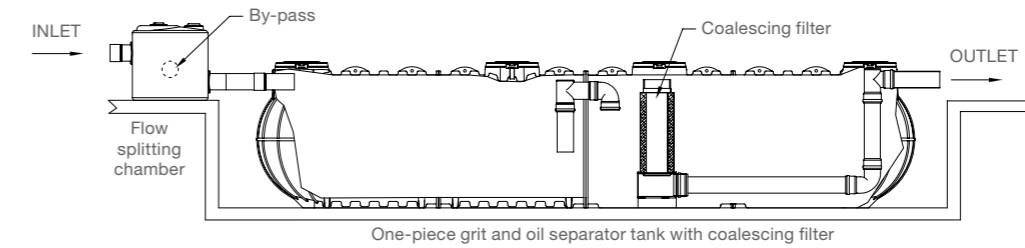

Item	Flow rate l/s	Uncovered area sq.m	Flow splitting chamber			Grit/oil separator				
			Model	Ø x H mm	IO-ØØ-BpØ mm	L x w x H mm	IO-ØØ mm	Useful volume l	Oil collection volume l	Sand collection volume l **
ITIPC12500	85	15300	PSC103131IPC	1160x1140	315-315-315	10140x2100x2200	315-315	27000	1300	8600

HORIZONTAL OIL SEPARATOR

WITH COALESCING FILTER AND EXTERNAL BYPASS

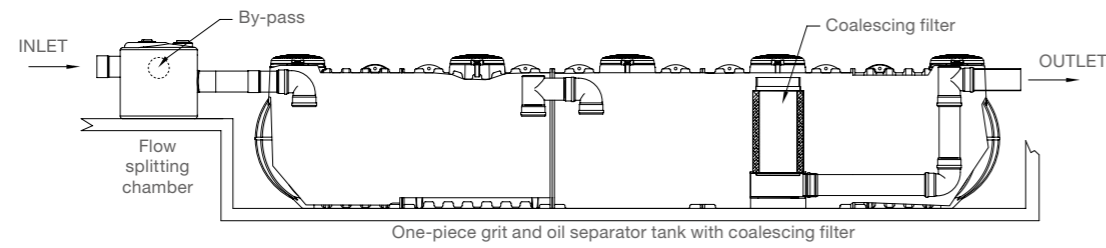

Item	Flow rate l/s	Uncovered area sq.m	Flow splitting chamber				Grit/oil separator			
			Model	Ø x H mm	IØ-ØØ-BpØ mm	L x w x H mm	IØ-ØØ mm	Useful volume l	Oil collection volume l	Sand collection l **
ITIPC14000	90	16200	PSC103131IPC	1160x1140	315-315-315	11200x2100x2200	315-315	29500	1400	9200

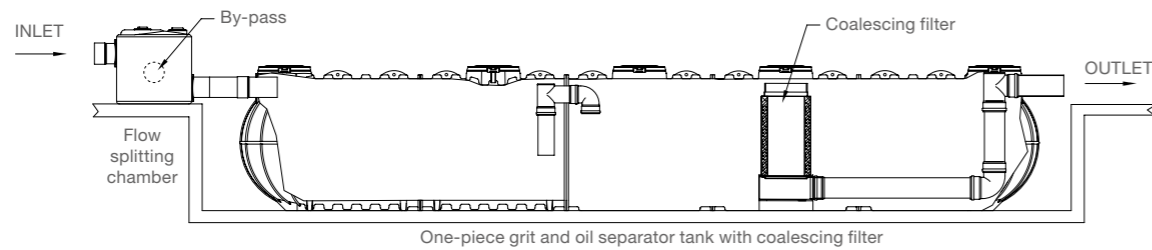

Item	Flow rate l/s	Uncovered area sq.m	Flow splitting chamber				Grit/oil separator			
			Model	Ø x H mm	IØ-ØØ-BpØ mm	L x w x H mm	IØ-ØØ mm	Useful volume l	Oil collection volume l	Sand collection l **
ITIPC15000	100	18000	PSC103131IPC	1160x1140	315-315-315	12400x2100x2200	315-315	33500	1550	10000

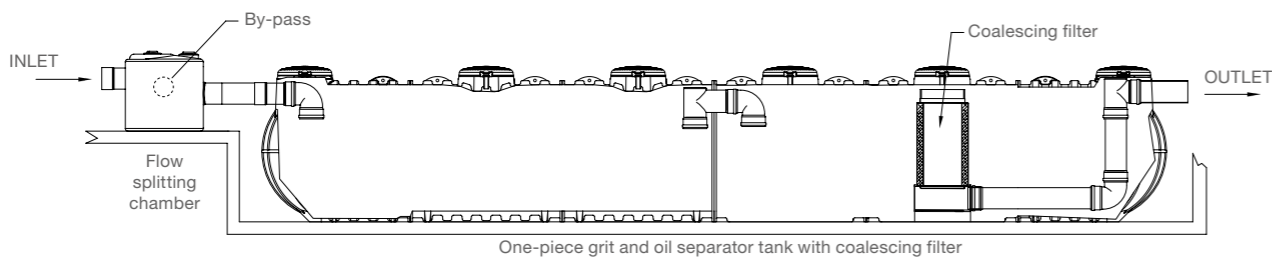

Item	Flow rate l/s	Uncovered area sq.m	Flow splitting chamber				Grit/oil separator			
			Model	Ø x H mm	IØ-ØØ-BpØ mm	L x w x H mm	IØ-ØØ mm	Useful volume l	Oil collection volume l	Sand collection l **
ITIPC16500	110	19800	PSC103131IPC	1160x1140	315-315-315	13460x2100x2200	315-315	36000	1700	11000

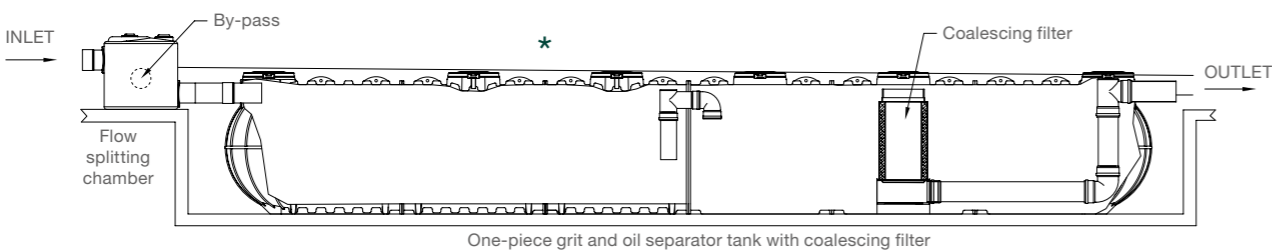

Item	Flow rate l/s	Uncovered area sq.m	Flow splitting chamber				Grit/oil separator			
			Model	Ø x H mm	IØ-ØØ-BpØ mm	L x w x H mm	IØ-ØØ mm	Useful volume l	Oil collection volume l	Sand collection l **
ITIPC18000	120	22000	PSC103131IPC	1160x1140	315-315-315	14660x2100x2200	315-315	40000	1850	13000

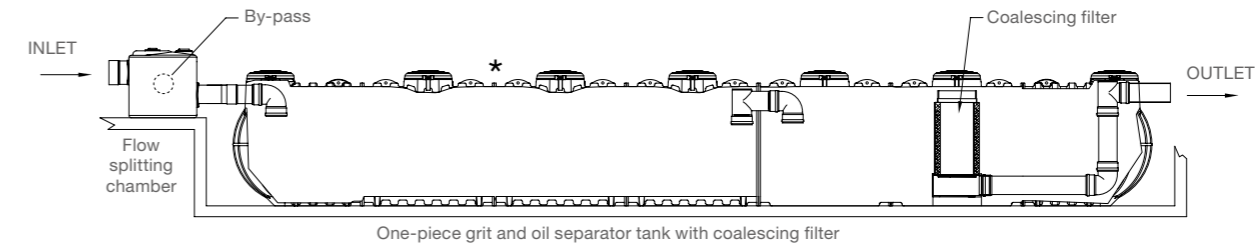

Item	Flow rate l/s	Uncovered area sq.m	Flow splitting chamber				Grit/oil separator			
			Model	Ø x H mm	IØ-ØØ-BpØ mm	L x w x H mm	IØ-ØØ mm	Useful volume l	Oil collection volume l	Sand collection l **
ITIPC19000	130	23400	PSC104031IPC	1160x1140	400-315-400	15720x2100x200	315-315	42500	2000	14000

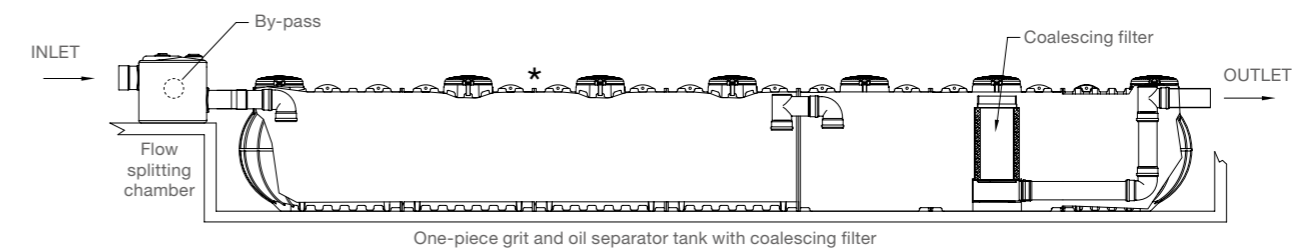

Item	Flow rate l/s	Uncovered area sq.m	Flow splitting chamber				Grit/oil separator			
			Model	Ø x H mm	IØ-ØØ-BpØ mm	L x w x H mm	IØ-ØØ mm	Useful volume l	Oil collection volume l	Sand collection l **
ITIPC20500	140	25200	PSC104031IPC	1160x1140	400-315-400	16310x2100x2200	315-315	44500	2150	14700

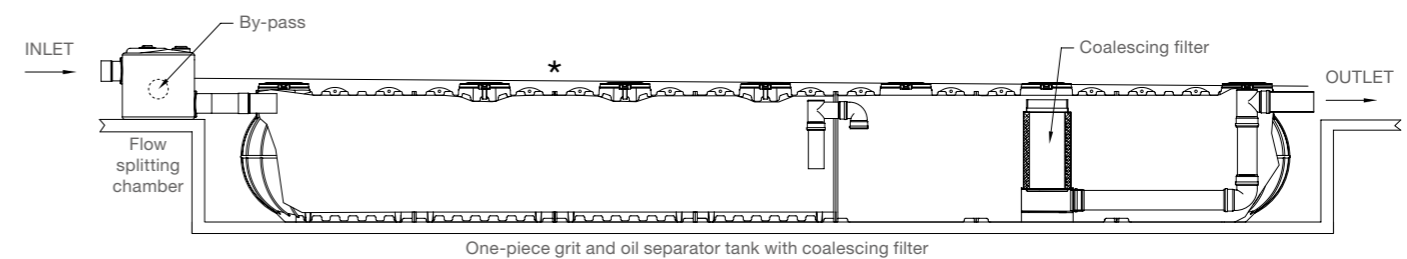

Item	Flow rate l/s	Uncovered area sq.m	Flow splitting chamber				Grit/oil separator			
			Model	Ø x H mm	IØ-ØØ-BpØ mm	L x w x H mm	IØ-ØØ mm	Useful volume l	Oil collection volume l	Sand collection l **
ITIPC22000	150	27000	PSC104031IPC	1160x1140	400-315-400	16920x2100x2200	315-315	46500	2300	15500

*ON-SITE WELDING

Where required, this will be carried out by specialist Rototec technicians and the cost will be calculated during the preparation of the offer.

NOTE: For larger sizes, please contact the Technical Office.

NOTE: The position of the asterisk is purely indicative.

FLOW SPLITTING CHAMBERS

MATERIAL

One-piece polyethylene tank (LLDPE) with PVC inlet and bypass pipes or PE pipe (dimension > 315) and PVC outlet pipe.

FUNCTION

The flow splitting chamber is installed upstream of a stormwater run-off treatment plant (IPP and IPC). Its function is to deliver rainwater to the treatment plant and to overflow the secondary non-polluting stormwater (IPP) elsewhere, or to convey the water in excess of the design flow of the plant to the continuous water treatment plant (IPC).

Item	Ø mm	H mm	HI mm	BpH mm	HO mm	I Ø mm	Bp Ø mm	Ø O mm	Cover
PSC011212IPP	580	660	260	250	160	125	125	125	CC200
PSC011212IPC	580	660	390	380	290	125	125	125	CC200
PSC051612IPP	790	790	400	340	220	160	160	125	CC400
PSC051616IPC	790	790	490	340	220	160	160	160	CC400
PSC052016IPC	790	790	450	340	220	200	200	160	CC400
PSC052020IPC	790	790	410	360	210	200	200	200	CC400
PSC052020IPP	790	790	420	360	220	200	200	200	CC400
PSC052516IPC	790	790	390	340	220	250	250	160	CC400
PSC052520IPP	790	790	390	350	220	250	250	200	CC400
PSC052520IPC	790	790	390	360	210	250	250	200	CC400
PSC052525IPC	790	790	350	300	110	250	250	250	CC400
PSC103120IPP	1160	1140	630	600	420	315	315	200	CC400
PSC103125IPP	1160	1140	630	580	390	315	315	250	CC400
PSC103131IPC	1160	1140	620	600	400	315	315	315	CC400
PSC104031IPC	1160	1140	570	480	240	400	400	315	CC400

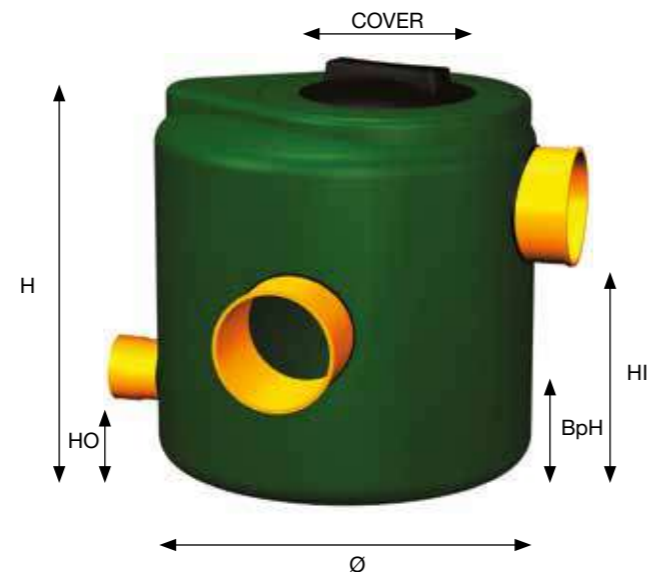

NOTES



SEWAGE



WATER



UNDERGROUND INSTALLATION



GRAVITY BALANCING TANKS

[FIND OUT MORE](#)



- 1 INLET PIPE**
To transfer the flow into the tank
- 2 STILLING ZONE**
For sedimentation of the suspended solids
- 3 OUTLET PIPE**
To regulate the flow of rainwater to discharge to the final receptor
- 4 SAFETY OVERFLOW**

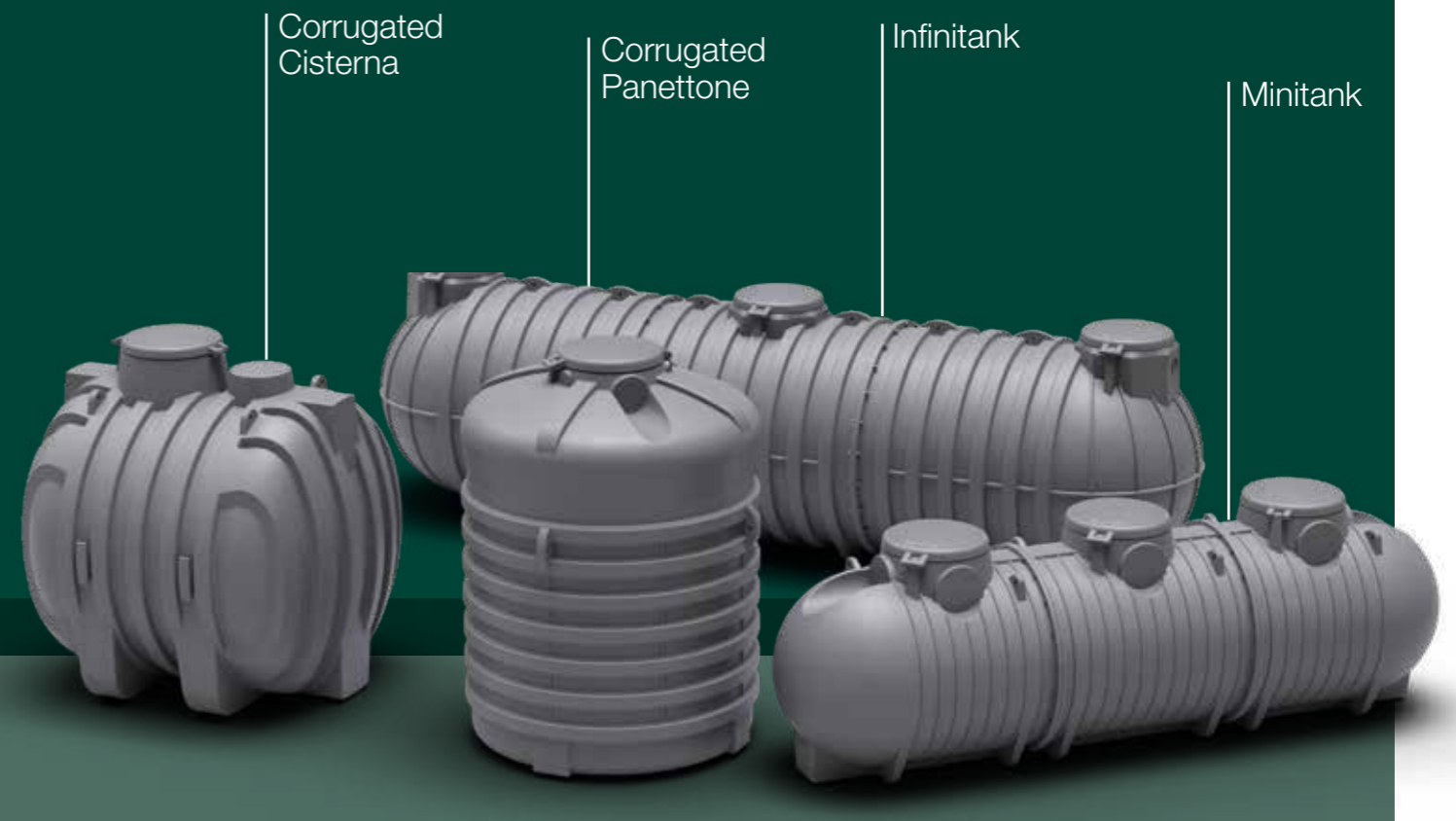

SPECIFICATIONS

TECHNICAL CHARACTERISTICS

The balancing tank is a temporary storage unit that has the purpose of regulating the flow of rainwater discharged into the final receptor (public sewer, ditch, watercourse,...). This is in order to discharge a flow that does not exceed the limit specified by the regional and local governments and/or the water authority.

The rainwater is fed to the balancing tank with pump through an inlet pipe and is discharged to the receptor by a submersible pump. The discharge flow rate of the pump can be controlled using a manual valve located on the pump delivery pipe. In this manner, in the case of heavy rainfall, the water exceeding the pump discharge rate is stored temporarily in the tank and released over a longer period of time.

Balancing tanks are required in all those areas where a high soil impermeability overloads stormwater sewerage systems, ditches or natural watercourses, thus creating rainwater disposal problems, above all during severe meteorological events.

USE

Temporary storage of rainwater collected from an impermeable surface (roads, car parks, roofs, coverings in general, warehouses, pavements, etc.) during a meteorological event.

INSTALLATION DIAGRAM

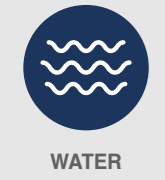
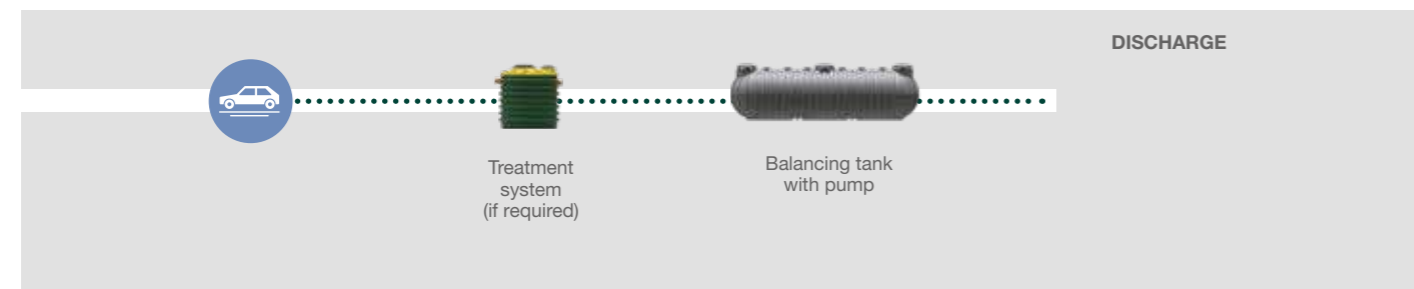

GRAVITY BALANCING TANKS

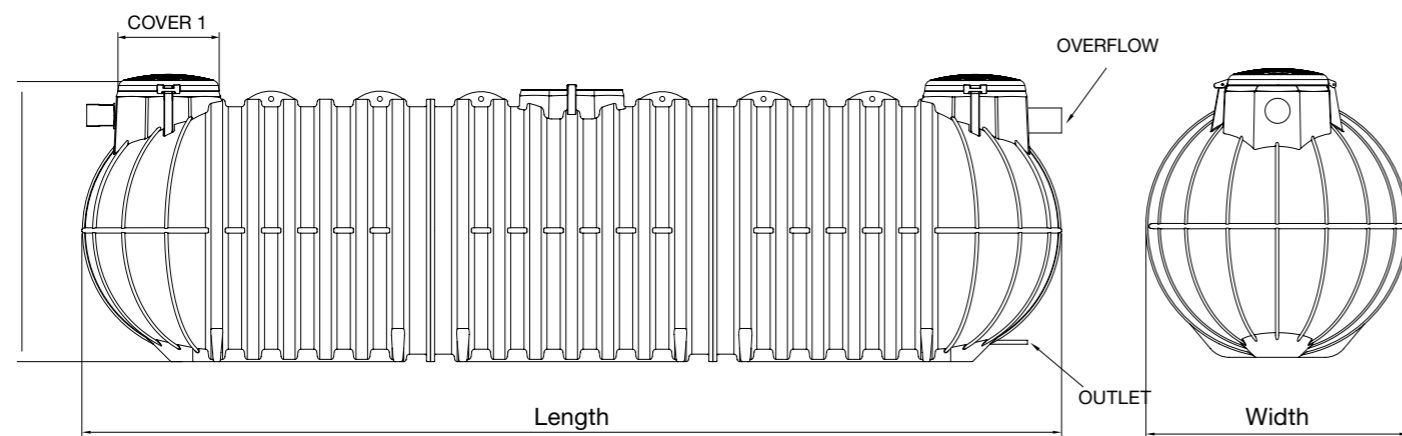
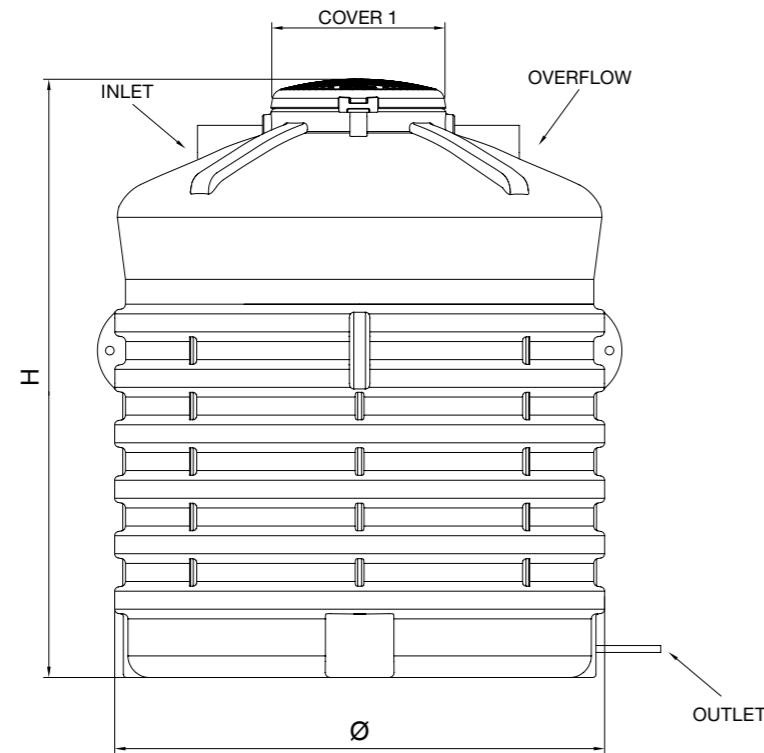

STORAGE TANKS

Item	Model	Capacity l	Length mm	Width mm	Ø mm	H mm	Covers	Extensions (optional)	Maximum inlet Ø* mm
CI3000	Cisterna	3100	2090	1500	-	1720	TAP800	PP77	160
NPI4000	Panettone	4050	-	-	1710	2150	TAP800	PP77	200
CI5700	Cisterna	5700	2420	1920	-	2100	TAP800	PP77	250
CI8700	Cisterna	8700	2660	2250	-	2360	TAP800	PP77	250
CI10700	Cisterna	10700	2780	2430	-	2580	TAP800	PP77	315
MT12000	Modular	12000	7180	1550	-	1710	TAP800	PP77	250
IT13000	Modular	13000	5010	2100	-	2200	TAP800	PP77	400
IT15000	Modular	15000	5620	2100	-	2200	TAP800	PP77	400
IT18000	Modular	18000	6680	2100	-	2200	TAP800	PP77	400
IT20000	Modular	20000	7270	2100	-	2200	TAP800	PP77	400
IT22000	Modular	22000	7880	2100	-	2200	TAP800	PP77	400
IT25000	Modular	25000	8940	2100	-	2200	TAP800	PP77	400
IT28000	Modular	28000	9530	2100	-	2200	TAP800	PP77	400
IT30000	Modular	30000	10140	2100	-	2200	TAP800	PP77	400
IT33000	Modular	33000	11200	2100	-	2200	TAP800	PP77	400
IT36000	Modular	36000	12400	2100	-	2200	TAP800	PP77	400
IT40000	Modular	40000	13460	2100	-	2200	TAP800	PP77	400
IT42000**	Modular	42000	14050	2100	-	2200	TAP800	PP77	400
IT45000**	Modular	45000	14660	2100	-	2200	TAP800	PP77	400
IT48000**	Modular	48000	15720	2100	-	2200	TAP800	PP77	400
IT50000**	Modular	50000	16310	2100	-	2200	TAP800	PP77	400
IT52000**	Modular	52000	16920	2100	-	2200	TAP800	PP77	400

*maximum diameter of inlet pipe that can be installed on the tank ** on-site welding carried out by specialist Rototec technicians

INLET AND OVERFLOW PIPES

Manufactured in PVC with NBR gasket, or with coupling for corrugated pipe in welded PE

Item	Type	Ø mm	Inlet flow rate l/s*
TRPVC110G	PVC	110	7.0
TRPVC125G	PVC	125	9.8
TRPVC160G	PVC	160	18.8
TRPVC200G	PVC	200	33.8
TRPVC250G	PVC	250	60.2
TRPVC315G	PVC	315	109.5
MANPE250	PE	250	60.2
MANPE315	PE	315	109.5
MANPE400	PE	400	203.11

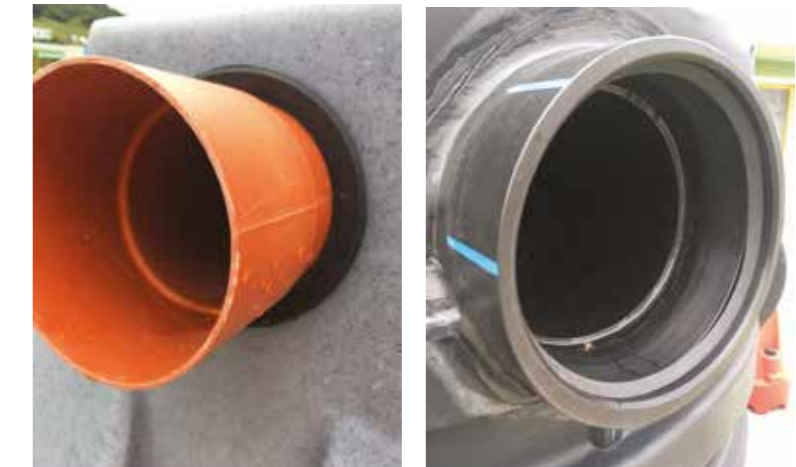

*inlet flow rate considering filling to 70% capacity and an inlet pipe gradient of 1%

DISCHARGE PIPE

Created using PE pipes welded to the tank

Item	Ø mm	Outlet flow rate l/s*
6TRPE040S	40	4.2
6TRPE050S	50	6.6
6TRPE063S	63	10.3
6TRPE075S	75	17.5
6TRPE090S	90	26.4
6TRPE125S	125	41.3



BALANCING TANKS WITH ELECTRIC PUMP

[FIND OUT MORE](#)



SEWAGE



WATER



UNDERGROUND INSTALLATION



- 1 INLET PIPE**
To transfer the flow into the tank
- 2 STILLING ZONE**
Where sedimentation of the incoming water takes place
- 3 SUBMERSIBLE ELECTRIC PUMP**
To regulate the flow of rainwater to discharge to the final receptor
- 4 SAFETY OVERFLOW**

INSTALLATION DIAGRAM

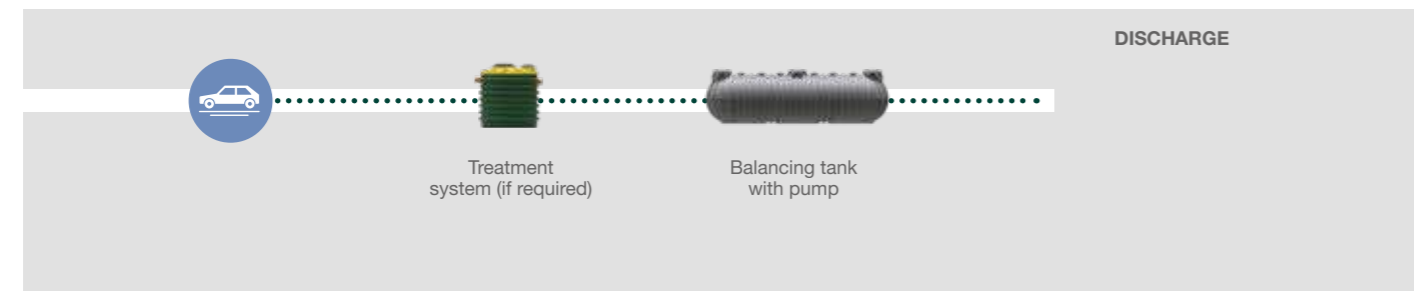

SPECIFICATIONS

TECHNICAL CHARACTERISTICS

The balancing tank is a temporary storage unit that has the purpose of regulating the flow of rainwater discharged into the final receptor (public sewer, ditch, watercourse,...). This is in order to discharge a flow that does not exceed the limit specified by the regional and local governments and/or the water authority.

The rainwater is fed to the balancing tank with pump through an inlet pipe and is discharged to the receptor by a submersible pump. The discharge flow rate of the pump can be controlled using a manual valve located on the pump delivery pipe. In this manner, in the case of heavy rainfall, the water exceeding the pump discharge rate is stored temporarily in the tank and released over a longer period of time.

Balancing tanks are required in all those areas where high soil impermeability overloads stormwater sewerage systems, ditches or natural watercourses, thus creating rainwater disposal problems, above all during severe meteorological events.

USE

Temporary storage of rainwater collected from an impermeable surface (roads, car parks, roofs, coverings in general, warehouses, pavements, etc.) during a meteorological event.



BALANCING TANKS WITH ELECTRIC PUMP

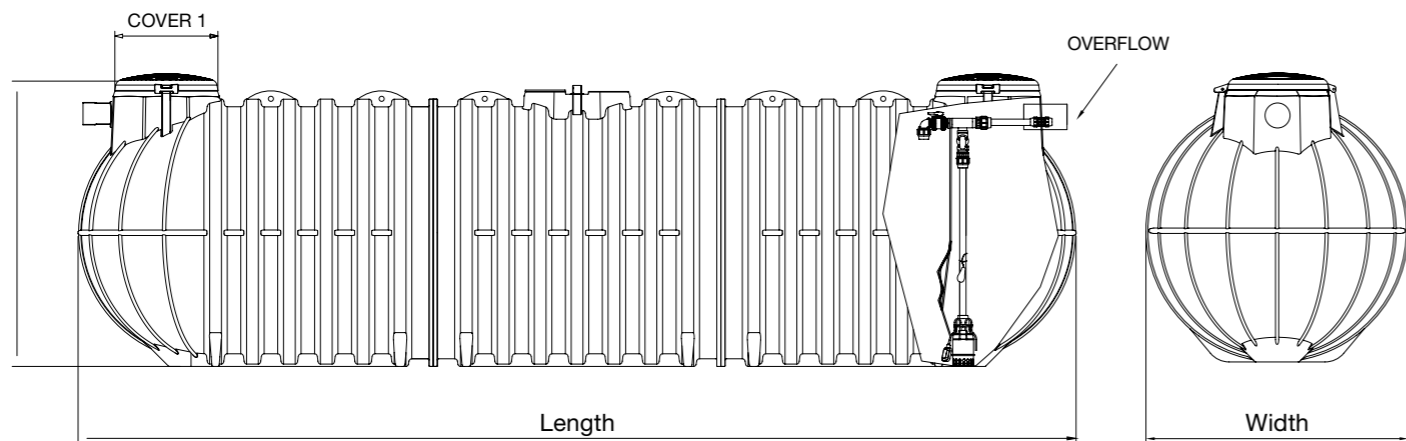
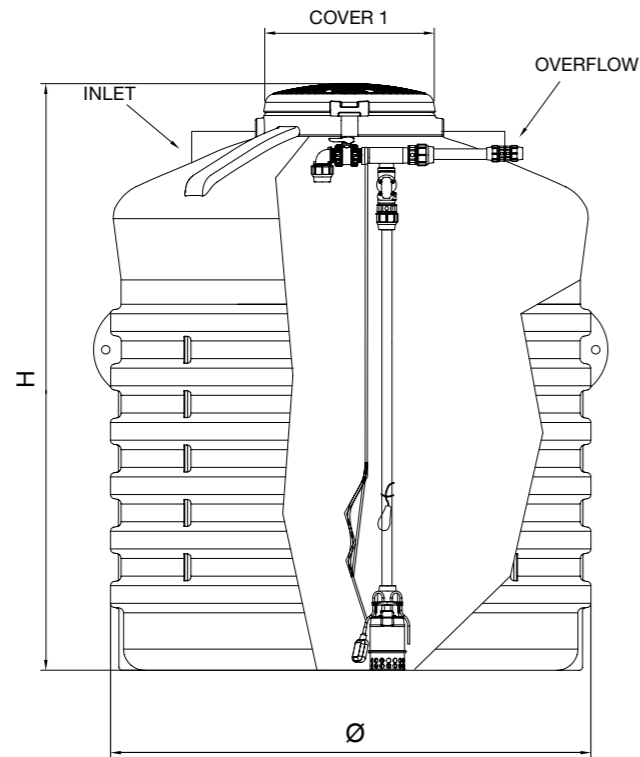

SEWAGE



WATER



UNDERGROUND INSTALLATION



STORAGE TANKS

Item	Model	Capacity l	Length mm	Width mm	Ø mm	H mm	Covers	Extensions (optional)	Maximum inlet Ø* mm
C13000	Cisterna	3100	2090	1500	-	1720	TAP800	PP77	160
NPI4000	Panettone	4050	-	-	1710	2150	TAP800	PP77	200
C15700	Cisterna	5700	2420	1920	-	2100	TAP800	PP77	250
C18700	Cisterna	8700	2660	2250	-	2360	TAP800	PP77	200
C110700	Cisterna	10700	2780	2430	-	2580	TAP800	PP77	315
MT12000	Modular	12000	7180	1550	-	1710	TAP800	PP77	250
IT13000	Modular	13000	5010	2100	-	2200	TAP800	PP77	400
IT15000	Modular	15000	5620	2100	-	2200	TAP800	PP77	400
IT18000	Modular	18000	6680	2100	-	2200	TAP800	PP77	400
IT20000	Modular	20000	7270	2100	-	2200	TAP800	PP77	400
IT22000	Modular	22000	7880	2100	-	2200	TAP800	PP77	400
IT25000	Modular	25000	8940	2100	-	2200	TAP800	PP77	400
IT28000	Modular	28000	9530	2100	-	2200	TAP800	PP77	400
IT30000	Modular	30000	10140	2100	-	2200	TAP800	PP77	400
IT33000	Modular	33000	11200	2100	-	2200	TAP800	PP77	400
IT36000	Modular	36000	12400	2100	-	2200	TAP800	PP77	400
IT40000	Modular	40000	13460	2100	-	2200	TAP800	PP77	400
IT42000**	Modular	42000	14050	2100	-	2200	TAP800	PP77	400
IT45000**	Modular	45000	14660	2100	-	2200	TAP800	PP77	400
IT48000**	Modular	48000	15720	2100	-	2200	TAP800	PP77	400
IT50000**	Modular	50000	16310	2100	-	2200	TAP800	PP77	400
IT52000**	Modular	52000	16920	2100	-	2200	TAP800	PP77	400

*maximum diameter of inlet pipe that can be installed on the tank ** on-site welding carried out by specialist Rototec technicians

INLET AND OVERFLOW PIPES

Manufactured in PVC with NBR gasket, or with coupling for corrugated pipe in welded PE

Item	Type	Ø mm	Inlet flow rate l/s*
6TRPVC110G	PVC	110	7.0
6TRPVC125G	PVC	125	9.8
6TRPVC160G	PVC	160	18.8
6TRPVC200G	PVC	200	33.8
6TRPVC250G	PVC	250	60.2
6TRPVC315G	PVC	315	109.5
6MANPE250	PE	250	60.2
6MANPE315	PE	315	109.5
6MANPE400	PE	400	203.11



*inlet flow rate considering filling to 70% capacity and an inlet pipe gradient of 1%

DELIVERY PUMP KIT

Electric delivery pump installed inside the balancing tank with start and stop float switch, delivery pipe in PE, clapet type check valve, manual valve for regulating the discharge flow.

Item	Power kW	Pump model	Min. Flow rate	Head m	Pipe Ø mm
7KSM155IPP	0.25	SM155L	0-200	6.5 - 0	50
7KSM265IPP	0.55	SM265L	0-300	8.5 - 1	50

*The price includes all fittings and installation of the kit in the tank



PLANTS FOR CAR WASHES

SPECIFICATIONS



SEWAGE



WATER



UNDERGROUND INSTALLATION



The growing interest for environmental protection and safety is focusing more and more not only on treatment of domestic sewage or the like but also, particularly in recent years, on treatment systems for run-off from potentially polluted impermeable surfaces.

This includes water from car washes, which is characterised by the presence of various types of pollutants such as: suspended solids (sand and mud, gravel, grit, plant residue,...), detergents, mineral oils and hydrocarbons. For this reason, the purification treatment of these effluents requires a series of phases that treat the pollutants in succession. Choice of the different types of treatment varies according to the final discharge (to public sewer, to surface watercourse, to land or re-use).

The first phase consists of a grit separator in which all the compounds of specific weight different to that of water are separated by gravity: the heavier materials (sand, mud, gravel,...) settle to the bottom of the tank while the lighter materials (oil, grease, foam,...) accumulate at the surface. The outlet pipe draws from halfway down the tank to prevent the separated material from being drawn-off.

The second phase is the oil separation. The residual oils and hydrocarbons are trapped by the coalescing filters, thus separating them from the effluent.

In the third phase, the effluent is subjected to intensive biologicals in which the particular strains of bacteria digest the dissolved organic substances (BOD and COD) and the detergents (Phosphorous). When discharging to a public sewer, the biological treatment consists of an aerated trickle filter. When discharging to a surface watercourse, another anaerobic trickle filter is added upstream. The blowers of the aerated trickle filters must remain in operation 24 hours a day.

Finally to improve the quality of the treated water to discharge it into the open air/to the land or to re-use it in the initial phases of the washing cycle (pre-wash,...), the treatment plant is combined with a tertiary treatment consisting of a quartzite and activated charcoal filter system.

USE

Treatment of water from manual and automatic car wash areas.

REFERENCE STANDARDS

Standard UNI EN 858-1 (oil separator).



[FIND OUT MORE](#)

[FIND OUT MORE](#)

PLANTS FOR CAR WASHES

DISCHARGE TO PUBLIC SEWER

PLANTS FOR CAR WASHES

DISCHARGE TO SURFACE WATERCOURSE

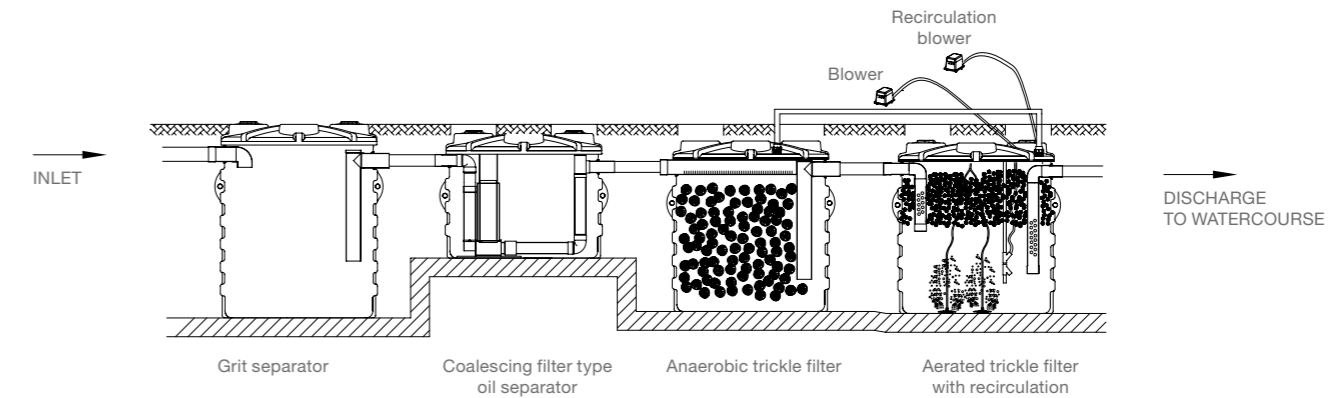
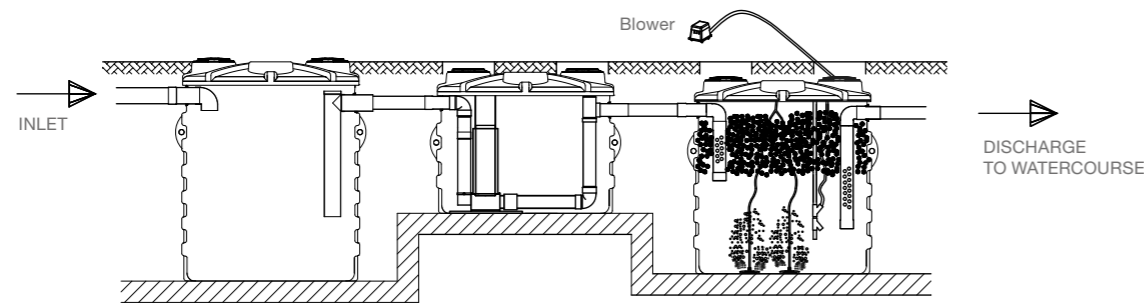

Item	Sizing			Plant composition											
	Cars per day	Hydraulic load l/day	Q max l/h	Grit separator				Oil separator				Aerated trickle filter			
				Model	Ø mm	H mm	Tot. Vol. l	Model	Ø mm	H mm	Model	Ø mm	H mm	Tot. Vol. l	
DEPAUTO10PF	0-10	2000	400	XDD1500	1150	1779	1444	XDOFC1000	1.5 l/s	1150	1220	XANA1000	1150	1220	850
DEPAUTO20PF	11-20	4000	400	NDD2600	1710	1450	1971	XDOFC1000	1.5 l/s	1150	1220	XANA1500	1150	1779	1268
DEPAUTO30PF	21-30	6000	600	NDD2600	1710	1450	1971	XDOFC1500	2 l/s	1150	1779	NANA2100	1350	1975	1950
DEPAUTO40PF	31-40	8000	800	NDD3200	1710	1725	2435	XDOFC1000	3 l/s	1150	1220	NANA2100	1350	1975	1950
DEPAUTO50PF	41-50	10000	1200	NDD3800	1710	1955	3026	XDOFC1500	4 l/s	1150	1779	NANA3200	1710	1725	2525
DEPAUTO60PF	51-60	12000	1500	NDD4600	1710	2225	3510	NDOFC2600	7.5 l/s	1710	1450	NANA3200	1710	1725	2525
DEPAUTO80PF	61-80	16000	2200	NDD6400	1950	2530	4862	NDOFC2600	7.5 l/s	1710	1450	NANA3800	1710	1955	3104
DEPAUTO100PF	81-100	20000	3000	NDD7000	2250	2367	6711	NDOFC2600	7.5 l/s	1710	1450	NANA4600	1710	2225	3835

Item	Sizing			Plant composition															
	Cars per day No.	Hydraulic load l/day	Q max l/h	Grit separator				Oil separator				Anaerobic trickle filter				Aerated trickle filter with sludge recirculation			
				Model	Ø mm	H mm	Useful vol. l	Model	Ø mm	H mm	Model	Ø mm	H mm	Tot. vol. l	Model	Ø mm	H mm	Tot. vol. l	
DEPAUTO10	0-10	2000	400	XDD1500	1150	1779	1444	XDOFC1000	1.5 l/s	1150	1220	XAN1000R	1150	1220	850	XANAR1000	1150	1220	850
DEPAUTO20	11-20	4000	400	NDD2600	1710	1450	1971	XDOFC1000	1.5 l/s	1150	1220	XAN1500R	1150	1779	1268	XANAR1500	1150	1779	1268
DEPAUTO30	21-30	6000	600	NDD2600	1710	1450	1971	XDOFC1500	2 l/s	1150	1720	XAN1500R	1150	1779	1268	NANAR2600	1710	1450	1971
DEPAUTO40	31-40	8000	800	NDD3200	1710	1725	2435	XDOFC1000	3 l/s	1150	1220	NAN2600R	1710	1450	1971	NANAR2600	1710	1450	1971
DEPAUTO50	41-50	10000	1200	NDD3800	1710	1955	3026	XDOFC1500	4 l/s	1150	1720	NAN3200R	1710	1725	2435	NANAR3200	1710	1725	2435
DEPAUTO60	51-60	12000	1800	NDD4600	1710	2225	3510	NDOFC2600	7.5 l/s	1710	1450	NAN3200R	1710	1725	2435	NANAR3200	1710	1725	2435
DEPAUTO80	61-80	16000	2200	NDD6400	1950	2530	4862	NDOFC2600	7.5 l/s	1710	1450	NAN3800R	1710	1955	3104	NANAR3800	1710	2225	3510
DEPAUTO100	81-100	20000	3000	NDD7000	2250	2367	6711	NDOFC2600	7.5 l/s	1710	1450	NAN4600R	1710	2225	3510	NANAR4600	1710	2225	3510



FIND OUT MORE

PLANTS FOR CAR WASHES

DISCHARGE TO SOIL OR RE-USE OF THE TREATED WATER

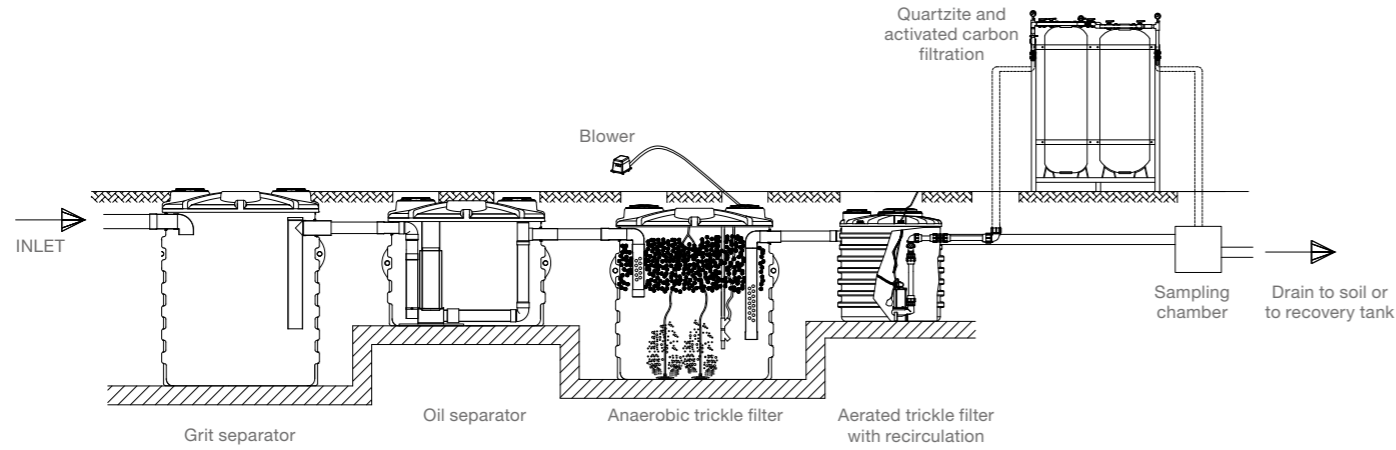

Item	Sizing			Plant composition																	
	Cars/day No.	Hydraulic load l/g	Q max l/h	Grit separator				Oil separator			Aerated trickle filter			Lift station			External filtration				
				Mod.	Ø mm	H mm	V. total l	Mod.	Ø mm	H mm	Mod.	Ø mm	H mm	Mod.	Ø mm	H mm	V. total l	Mod.	L x w mm	H mm	
DEPAUTO10T4*	0-10	2000	400	XDD1500	1150	1720	1444	XDOFC1000	1.5 l/s	1150	1220	XANA1000	1150	1220	XSOL1005EC	1150	1220	900	FQCA05	900x40	1650
DEPAUTO20T4*	11-20	4000	400	NDD2600	1710	1450	1971	XDOFC1000	1.5 l/s	1150	1220	XANA1500	1150	1220	XSOL1005EC	1150	1220	900	FQCA05	900x40	1650
DEPAUTO30T4*	21-30	6000	600	NDD2600	1710	1450	1971	XDOFC1500	2 l/s	1150	1779	NANA2100	1350	1975	XSOL1008EC	1150	1220	900	FQCA08	1400x600	2000
DEPAUTO40T4*	31-40	8000	800	NDD3200	1710	1725	2435	XDOFC1000	3 l/s	1150	1220	NANA2100	1350	1975	XSOL1008EC	1150	1220	900	FQCA08	1400x600	2000
DEPAUTO50T4	41-50	10000	1200	NDD3800	1710	1955	3026	NDOFC1500	4 l/s	1150	1779	NANA3200	1710	1725	XSOL1500EC	1150	1779	1400	FQCA1	1400x600	2000
DEPAUTO60T4	51-60	12000	1500	NDD4600	1710	2225	3510	NDOFC2600	7.5 l/s	1710	1450	NANA3200	1710	1725	XSOL1500EC	1150	1779	1400	FQCA1	1400x600	2000
DEPAUTO80T4	61-80	16000	2200	NDD6400	1950	2530	5100	NDOFC2600	7.5 l/s	1710	1450	NANA3800	1710	1955	NSOL3000EC	1710	1650	3000	FQCA2	1800x1000	2000
DEPAUTO100T4	81-100	20000	3000	NDD7000	2250	2367	6711	NDOFC2600	7.5 l/s	1710	1450	NANA4600	1710	2225	NSOL3000EC	1710	1650	3000	FQCA2	1800x1000	2000



ABOVE-GROUND PLANTS FOR CAR WASHES

DISCHARGE TO PUBLIC SEWER

N.B.: For larger sizes, up to 100 cars/day, and for discharge to soil and/or re-use, please contact our technical office.

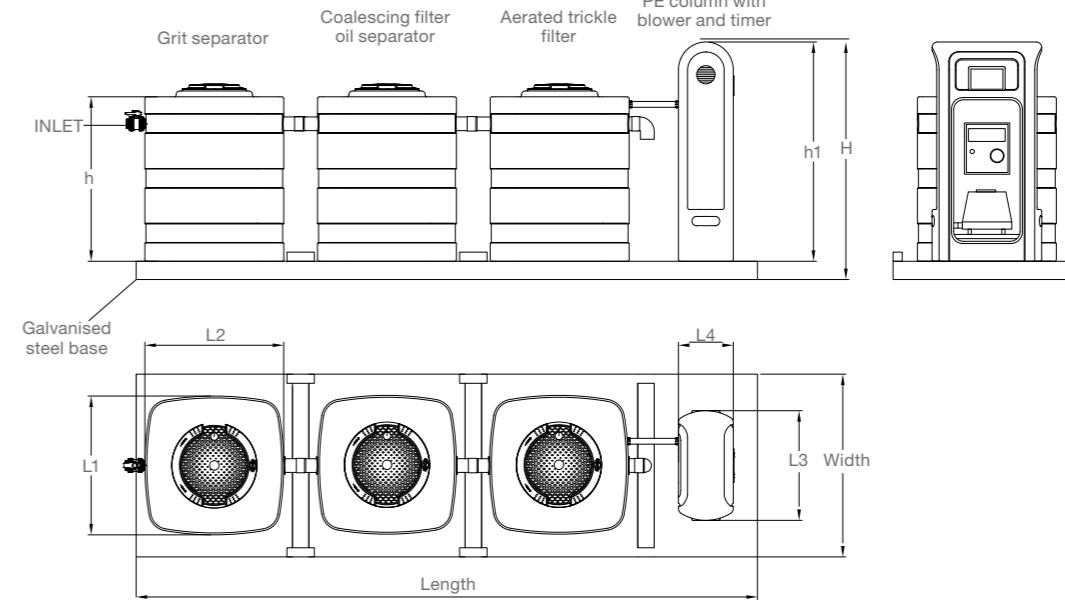

Item	Cars/day No.	Total working dimensions length x width x H mm	Grit separator/Oil separator/filter L1 x L2 x h mm	Bollard L3 x L4 x h1 mm	Ø - Ø0 mm	Total volume l	Blower W
DEPAUTOEST10	0-10	3400 x 1000 x 1300	760 x 760 x 980	300 x 600 x 1200	50-75	1350	31

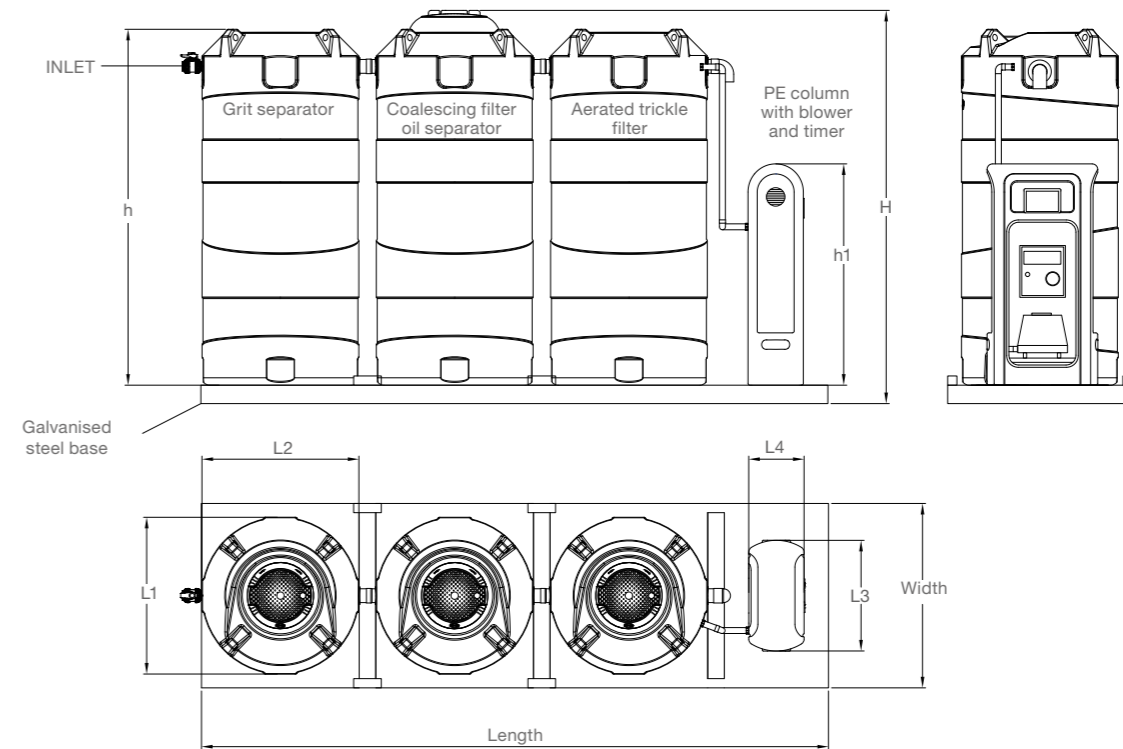

Item	Cars/day No.	Total working dimensions length x width x H mm	Grit separator/Oil separator/filter L1 x L2 x h mm	Bollard L3 x L4 x h1 mm	Ø - Ø0 mm	Total volume l	Blower W
DEPAUTOEST20	11-20	3400 x 1000 x 2003	850 x 850 x 1930	300 x 600 x 1200	50-75	2700	31

ABOVE-GROUND PLANTS FOR CAR WASHES WITHOUT SKID

DISCHARGE TO PUBLIC SEWER

N.B.: For larger sizes, up to 100 cars/day, and for discharge to soil and/or re-use, please contact our technical office.

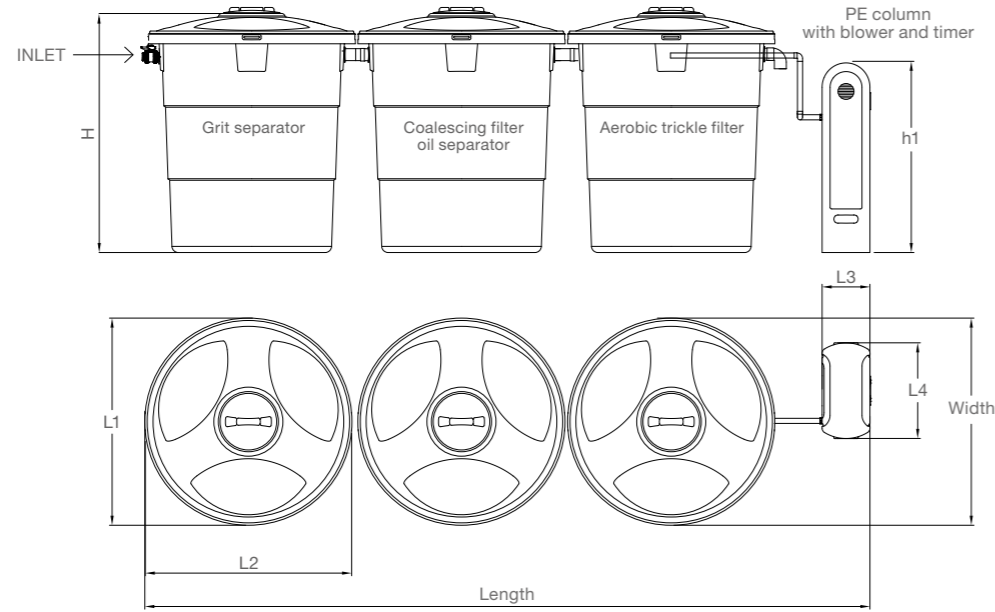

Item	Cars/day No.	Total working dimensions length x width x H mm	Grit separator/Oil separator/filter L1 x L2 x h mm	Bollard L3 x L4 x h1 mm	IØ - ØØ mm	Total volume l	Blower W
DEPAUTOEST25	21-25	510 x 130 x 150	130 x 130 x 150	300 x 600 x 1200	50-75	3750	60

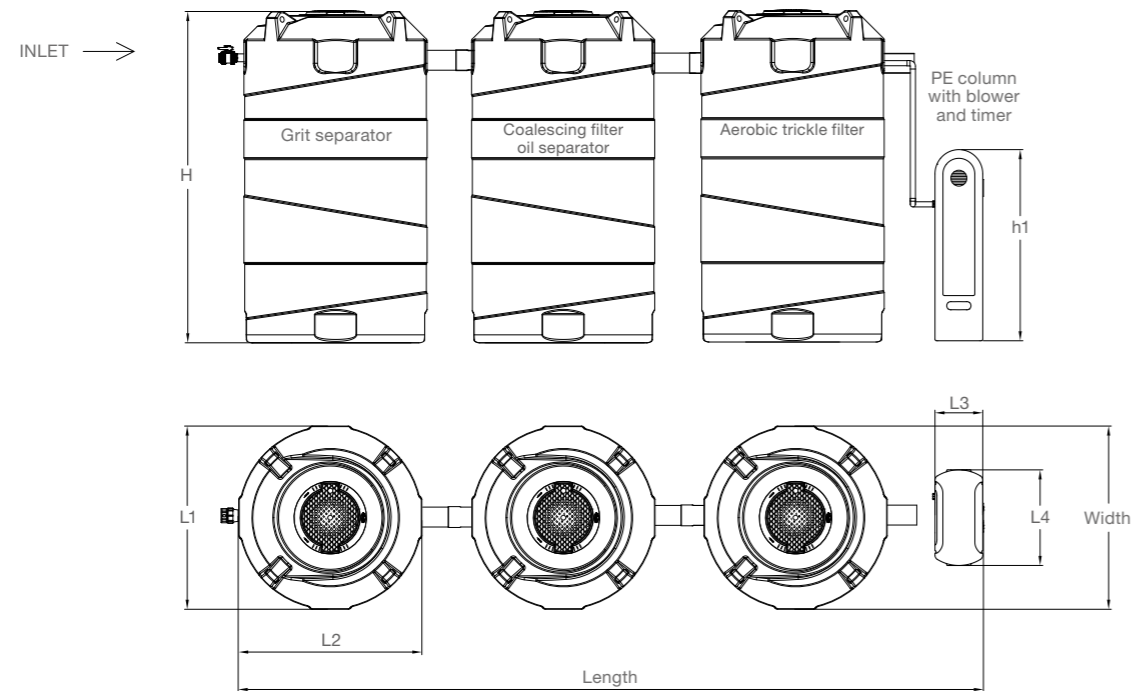

Item	Cars/day No.	Total working dimensions length x width x H mm	Grit separator/Oil separator/filter L1 x L2 x h mm	Bollard L3 x L4 x h1 mm	IØ - ØØ mm	Total volume l	Blower W
DEPAUTOEST40	26-40	465 x 115 x 208	115 x 115 x 208	300 x 600 x 1200	50-75	5500	60

NOTES

QUARTZITE AND ACTIVATED CARBON FILTRATION



SEWAGE



WATER



UNDERGROUND INSTALLATION



DESCRIPTION OF THE PLANT

One-piece filtration plants are the most rational and economic means of treating effluent characterised by pollution due to the presence of substances such as Suspended Solids, Hydrocarbons and Surfactants from: car washes, mechanical workshops, etc.. Their economy of operation relates to their ability to work without the need for operator intervention, which is only required for a few minutes/week, during the periodic wash-out operations. The systems do not require chemical products for operation, so the salt content of the waste water is not altered. This is particularly advantageous in all cases when partial re-use of the treated water is required.

The filtration lines consist of two tanks or columns, equipped with No. 2 manholes, to allow periodic operations to load and replace the Quartzite and/or Activated Charcoal filter beds. These are extremely reliable and long-lasting finished products, that are able to withstand both the action of chemical agents and the weather. All the electromechanical equipment installed to support the plant feature maximum reliability, extreme simplicity of use and a minimum need for maintenance.

THE TREATMENT CYCLE FOR DISCHARGE TO LAND OR RE-USE

1. The water to be treated following external car washing activities is carried to the pre-treatment section, which consists of grit separator, coalescing filter oil separator and aerated trickle filter;
2. The waste water leaving the pre-treatment section enters a so-called homogenisation and storage tank, which contains the submerged electric pump used to power the plant.
3. The pre-treated water is then sent to the first stage of filtration, where it passes through a bed of ultra-fine Quartzite, with a suspended substance selection level of around 50µm.
4. After this, the clarified waste water moves on to the second stage of filtration, consisting of an Activated Charcoal bed. The feature of activated charcoal is its ability to retain, within its microporous structure, pollutants such as, for example, Surfactants, Hydrocarbons, Solvents etc.



Layout FQCA05 - FQCA08 - FQCA1

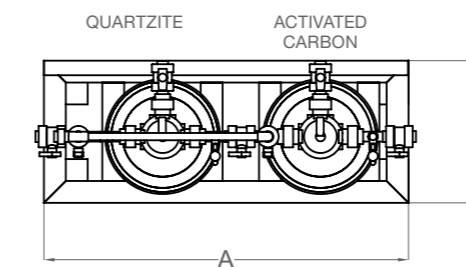
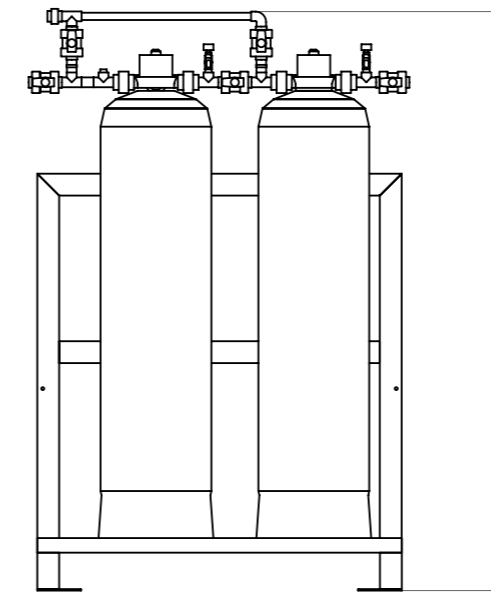

Layout FQCA2

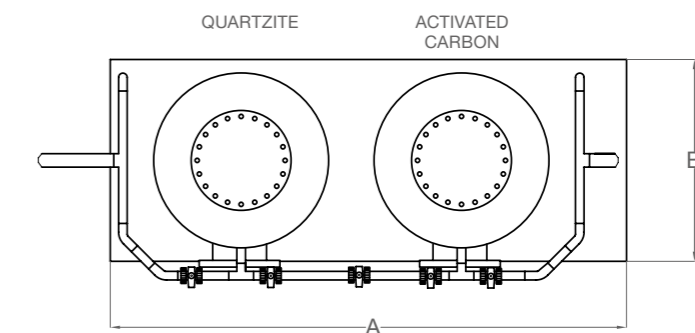
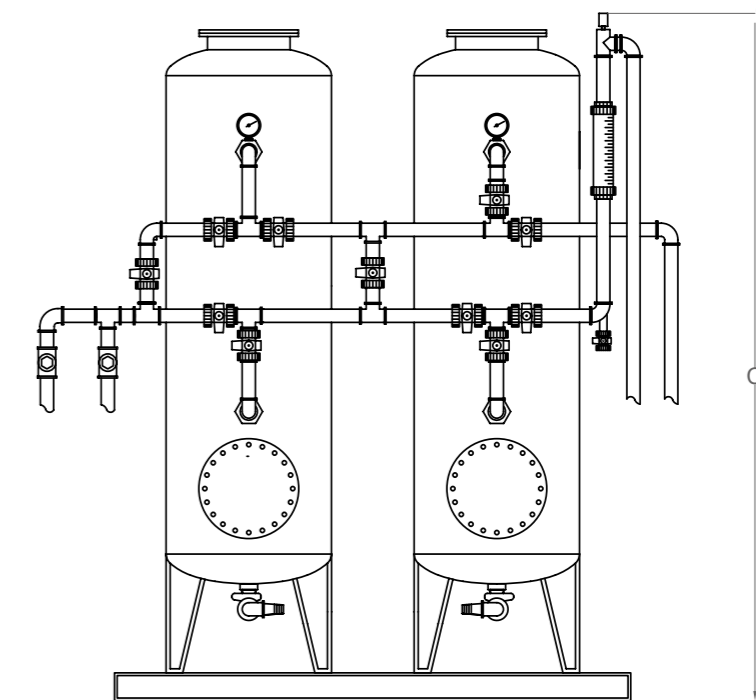

Item	Flow rate l/h	Overall SKID dimensions			Installed power Kw	Power supply voltage V	Weight during service Kg	Column material
		A cm	B cm	C cm				
KITFQCA05*	500	90	40	165	0.44	220	200	Fibreglass
KITFQCA08*	800	140	60	200	0.44	220	400	Fibreglass
KITFQCA1*	1500	140	60	200	1.1	380	500	Fibreglass
KITFQCA2*	3000	180	100	200	1.5	380	1200	Carbon steel

* Panel and electric pump included

LIFT STATIONS

[FIND OUT MORE](#)

CE
UNI EN 12050-1



- 1 SUBMERSIBLE ELECTRIC PUMPS
- 2 STAINLESS STEEL DOWNPIPE AND QUICK-CONNECTION SYSTEM
- 3 CONTROL FLOATS
- 4 CAST IRON BALL BACKFLOW VALVE
- 5 OUTLET PIPES

TECHNICAL CHARACTERISTICS

Sewage lift stations are systems that allow effluent to be lifted and transferred to stations located at higher levels (sewerage systems, treatment systems). They become necessary, for example, when the discharge level of a WC is lower than that of the treatment plant or sewerage pipes (cellars, underground premises, etc.) and when the hydraulic profile of the treatment system cannot work by gravity. The station consists of a high density linear polyethylene (LHDPE) storage tank of various sizes, with a submerged electric pump installed inside it. Dual pump models are provided if the flow rates of waste water to be lifted are very high and/or variable and if the presence of a spare pump is necessary. The pumps are connected to suitable electric panels so that, according to requirements, the start-up command can be either manual or automatic by means of start/stop float switches located inside the tank. Depending on need, the lift stations can be equipped with various types of pumps with different heads, flow rates and working pressures. For pumps with special characteristics, contact the ROTOTEC technical office.

USE

To pump pre-treated and untreated waste water, rainwater, etc. to higher levels.

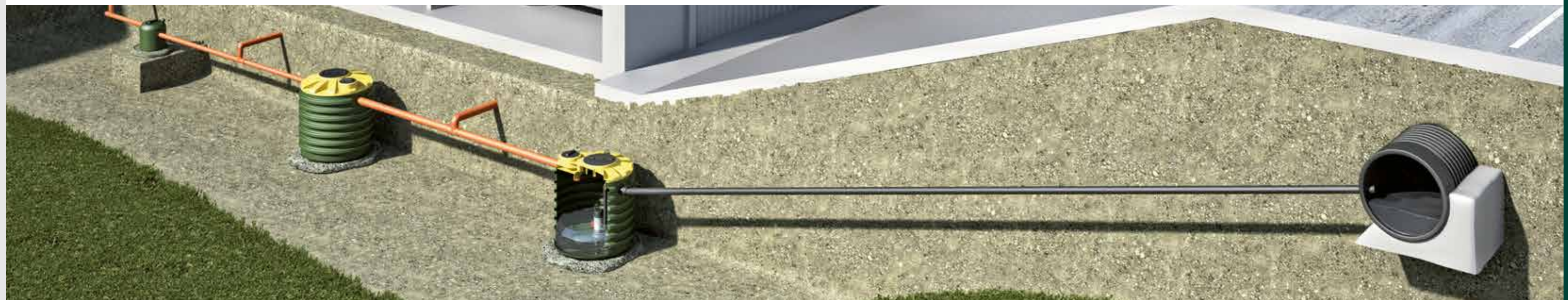

ROTOTEC



SEWAGE



WATER



UNDERGROUND
INSTALLATION



PICO SOL LIFT STATION

SMALL VOLUMES

SOL

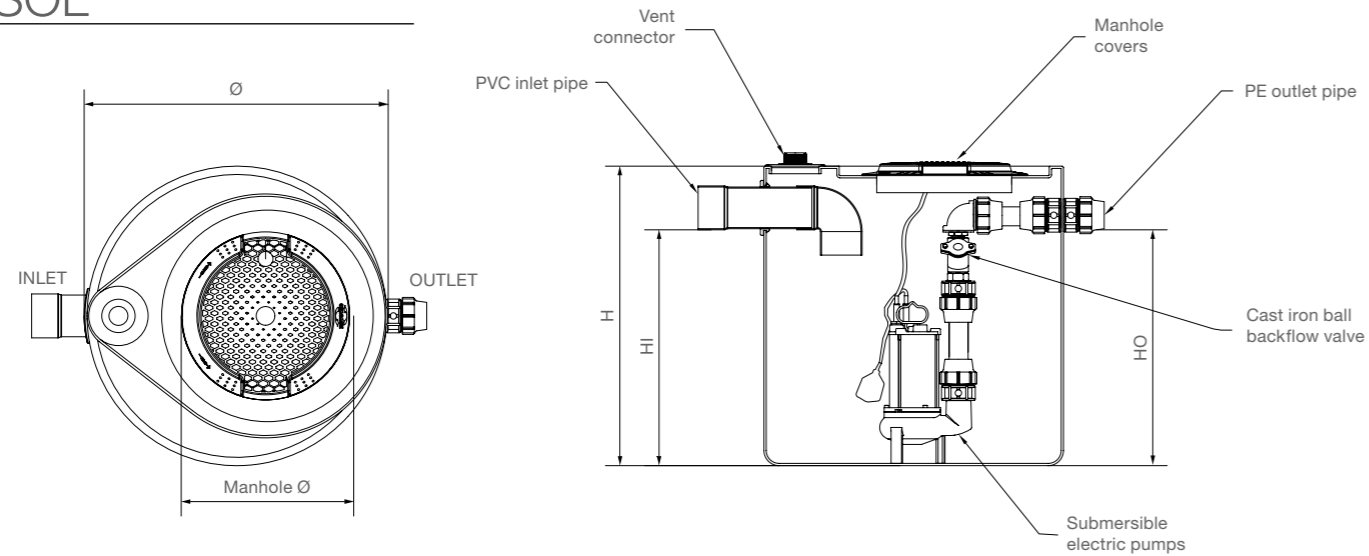

NSOL

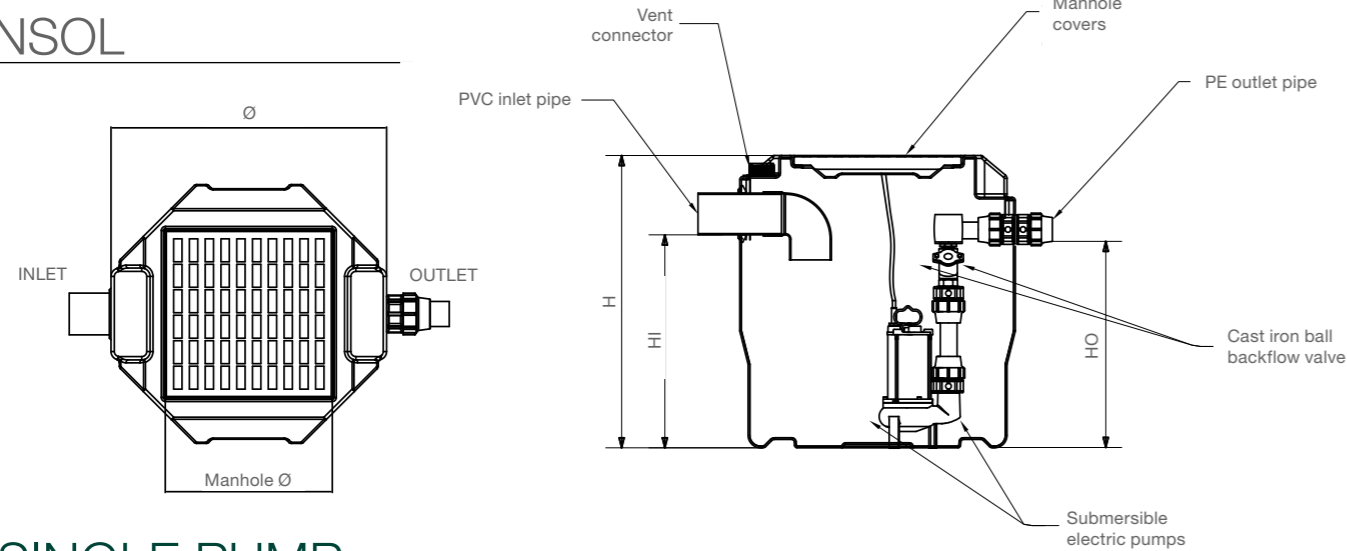

SINGLE PUMP

Item	Vol. l	Ø mm	H mm	HI mm	HO mm	Ø I/O mm	Manhole Ø mm	Pump	Impeller type	kW	Flow rate l/min	Head m
SOL150	120	580	660	510	510	100-50	300	PNRG01	Vortex	0.3	10-140	6-1
NSOL150	130	660	550	363	330	110-50	400	PNRG01	Vortex	0.3	10-140	6-1
NSOL326	175	660	700	513	490	110-50	400	SM265	Vortex	0.55	0-300	8.5-1
SOL326	230	630	970	750	750	110-50	400	SM265	Vortex	0.55	0-300	8.5-1
NSOL345	175	660	700	513	490	110-63	400	SM390	Vortex	0.75	0-500	10.5-1
SOL345	230	630	970	750	750	110-63	400	SM390	Vortex	0.75	0-500	10.5-1
NSOL312	175	660	700	513	490	110-63	400	SM125	Grinder	1.18	0-110	30-3
SOL312	230	630	970	750	750	110-63	400	SM125	Grinder	1.18	0-110	30-3
NSOL302	175	660	700	513	490	110-63	400	PMST2	Grinder	0.9	35-215	16-4
SOL302	230	630	970	750	750	110-63	400	PMST2	Grinder	0.9	35-215	16-4
SOL526	305	790	790	625	625	110-50	400	SM265	Vortex	0.55	0-300	8.5-1
SOL545	305	790	790	625	625	110-63	400	SM390	Vortex	0.75	0-500	10.5-1
SOL563	305	790	790	625	625	110-63	400	SM635	Two-channel	1.1	0-650	15-0
SOL512	305	790	790	625	625	110-63	400	SM125	Grinder	1.18	0-110	30-0
SOL502	305	790	790	625	625	110-63	400	PMST2	Grinder	0.9	35-215	16-4

Single and dual-pump lift stations, size 120-300 l

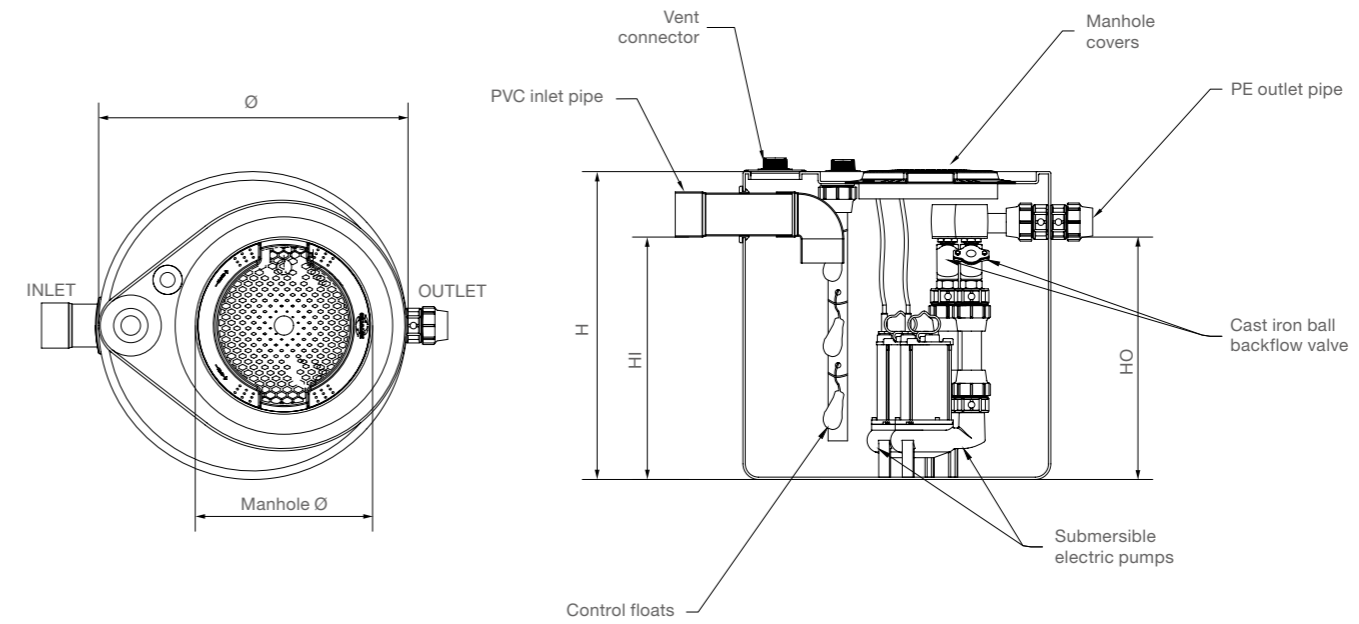

DUAL PUMP

Item	Vol. l	Ø mm	H mm	HI mm	HO mm	Ø I/O mm	Manhole Ø mm	Pump	Impeller type	kW	Flow rate l/min	Head m
SOL526P2	305	790	790	625	625	110-50	400	SM265	Arretrata	0.55	0-300	8.5-1
SOL545P2	305	790	790	625	625	110-63	400	SM390	Arretrata	0.75	0-500	10.5-1
SOL563P2	305	790	790	625	625	110-63	400	SM635	Bicanale	1.1	0-650	15-0
SOL512P2	305	790	790	625	625	110-63	400	SM125	Trituratrice	1.18	0-110	30-0
SOL502P2	305	790	790	625	625	110-63	400	PMST2	Trituratrice	0.9	35-215	16-4



ENNE SOL LIFT STATIONS

LARGE VOLUMES

Single and dual-pump lift stations, size 900-3000 l

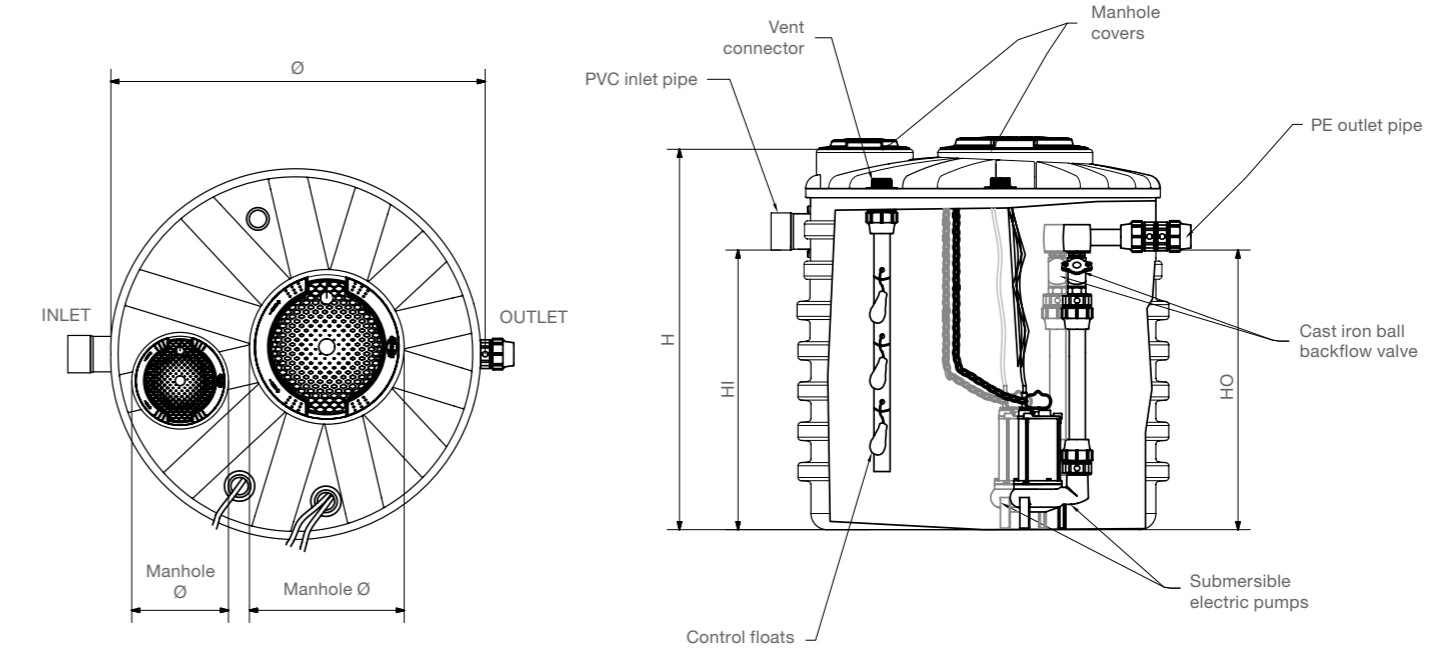
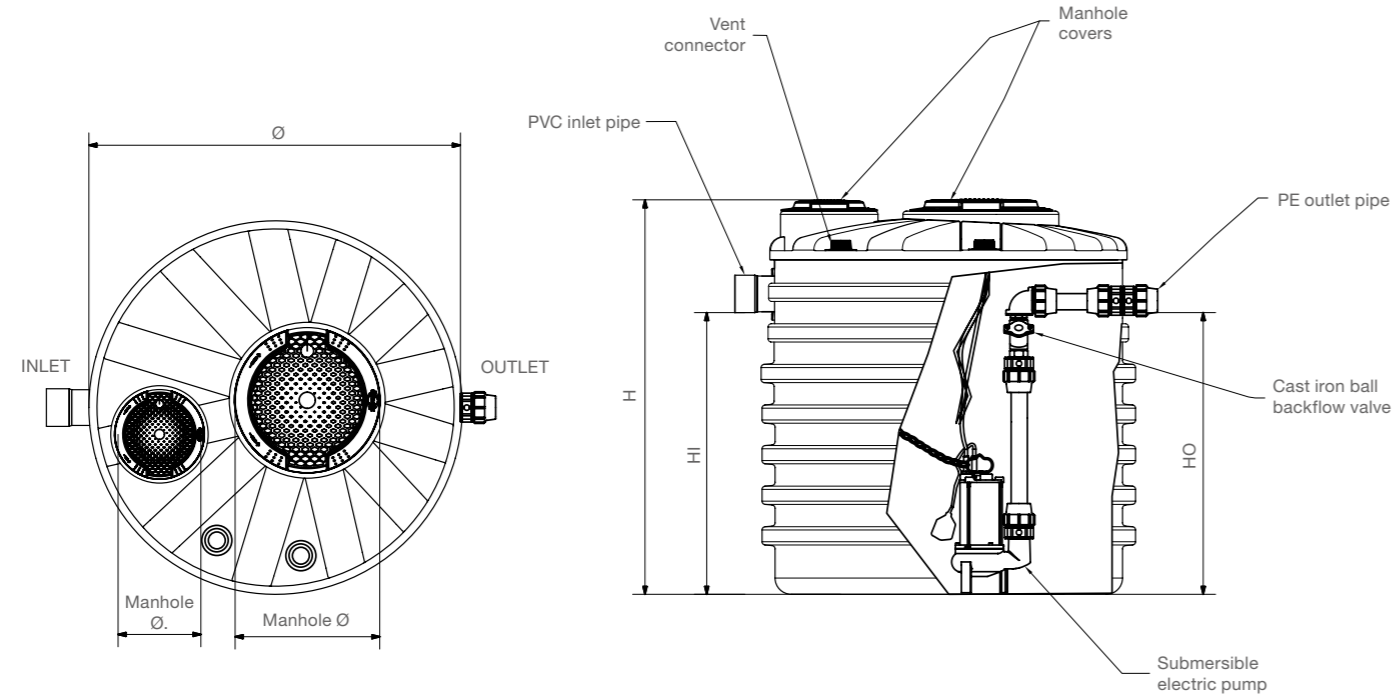

SINGLE PUMP

Item	Vol. l	Ø mm	H mm	Hi mm	HO mm	I/O Ø mm	Manhole Ø mm	Pump	Impeller type	kW	Flow rate l/min	Head m
XSOL1026	903	1150	1221	870	870	110-63	400-210	SM265	Vortex	0.55	0-300	8.5-1
XSOL1045	903	1150	1221	870	870	110-63	400-210	SM390	Vortex	0.75	0-500	10.5-1
XSOL1063	903	1150	1221	870	870	110-63	400-210	SM635	Two-channel	1.1	0-650	15-0
XSOL1012	903	1150	1221	870	870	110-63	400-210	SM125	Grinder	1.18	0-110	30-3
XSOL1002	903	1150	1221	870	870	110-63	400-210	PMST2	Grinder	0.9	35-215	16-4
XSOL1526	1400	1150	1779	1360	1360	125-50	400-210	SM265	Vortex	0.55	0-300	8.5-1
XSOL1545	1400	1150	1779	1360	1360	125-63	400-210	SM390	Vortex	0.75	0-500	10.5-1
XSOL1563	1400	1150	1779	1360	1360	125-63	400-210	SM635	Two-channel	1.1	0-650	15-0
XSOL1512	1400	1150	1779	1360	1360	125-63	400-210	SM125	Grinder	1.18	0-110	30-3
XSOL1502	1400	1150	1779	1360	1360	125-63	400-210	PMST2	Grinder	0.9	35-215	16-4
NSOL3026	3000	1710	1650	1355	1355	125-50	630	SM265	Vortex	0.55	0-300	8.5-1
NSOL3045	3000	1710	1650	1355	1355	125-63	630	SM390	Vortex	0.75	0-500	10.5-1
NSOL3063	3000	1710	1650	1355	1355	125-63	630	SM635	Two-channel	1.1	0-650	15-0
NSOL3012	3000	1710	1650	1355	1355	125-63	630	SM125	Grinder	1.18	0-110	30-3
NSOL3002	3000	1710	1650	1355	1355	125-63	630	PMST2	Grinder	0.9	35-215	16-4
NSOL3004	3000	1710	1650	1355	1355	125-63	630	PMST4	Grinder	1.5	20-245	22-6

DUAL PUMP

Item	Vol. l	Ø mm	H mm	Hi mm	HO mm	I/O Ø mm	Manhole Ø mm	Pump	Impeller type	kW	Flow rate l/min	Head m
XSOL1026P2	903	1150	1221	870	870	110-63	400-210	SM265	Vortex	0.55	0-300	8.5-1
XSOL1045P2	903	1150	1221	870	870	110-63	400-210	SM390	Vortex	0.75	0-500	10.5-1
XSOL1063P2	903	1150	1221	870	870	110-63	400-210	SM635	Two-channel	1.1	0-650	15-0
XSOL1012P2	903	1150	1221	870	870	110-63	400-210	SM125	Grinder	1.18	0-110	30-3
XSOL1002P2	903	1150	1221	870	870	110-63	400-210	PMST2	Grinder	0.9	35-215	16-4
XSOL1526P2	1400	1150	1779	1360	1360	125-63	400-210	SM265	Vortex	0.55	0-300	8.5-1
XSOL1545P2	1400	1150	1779	1360	1360	125-63	400-210	SM390	Vortex	0.75	0-500	10.5-1
XSOL1563P2	1400	1150	1779	1360	1360	125-63	400-210	SM635	Two-channel	1.1	0-650	15-0
XSOL1512P2	1400	1150	1779	1360	1360	125-63	400-210	SM125	Grinder	1.18	0-110	30-3
XSOL1502P2	1400	1150	1779	1360	1360	125-63	400-210	PMST2	Grinder	0.9	35-215	16-4
NSOL3026P2	3000	1710	1650	1355	1355	125-63	630	SM265	Vortex	0.55	0-300	8.5-1
NSOL3045P2	3000	1710	1650	1355	1355	125-63	630	SM390	Vortex	0.75	0-500	10.5-1
NSOL3063P2	3000	1710	1650	1355	1355	125-63	630	SM635	Two-channel	1.1	0-650	15-0
NSOL3012P2	3000	1710	1650	1355	1355	125-63	630	SM125	Grinder	1.18	0-110	30-3
NSOL3002P2	3000	1710	1650	1355	1355	125-63	630	PMST2	Grinder	0.9	35-215	16-4
NSOL3004P2	3000	1710	1650	1355	1355	125-63	630	PMST4	Grinder	1.5	20-245	22-6



TEKNOSOL LIFT STATIONS

SINGLE PUMP



SEWAGE



WATER



UNDERGROUND INSTALLATION

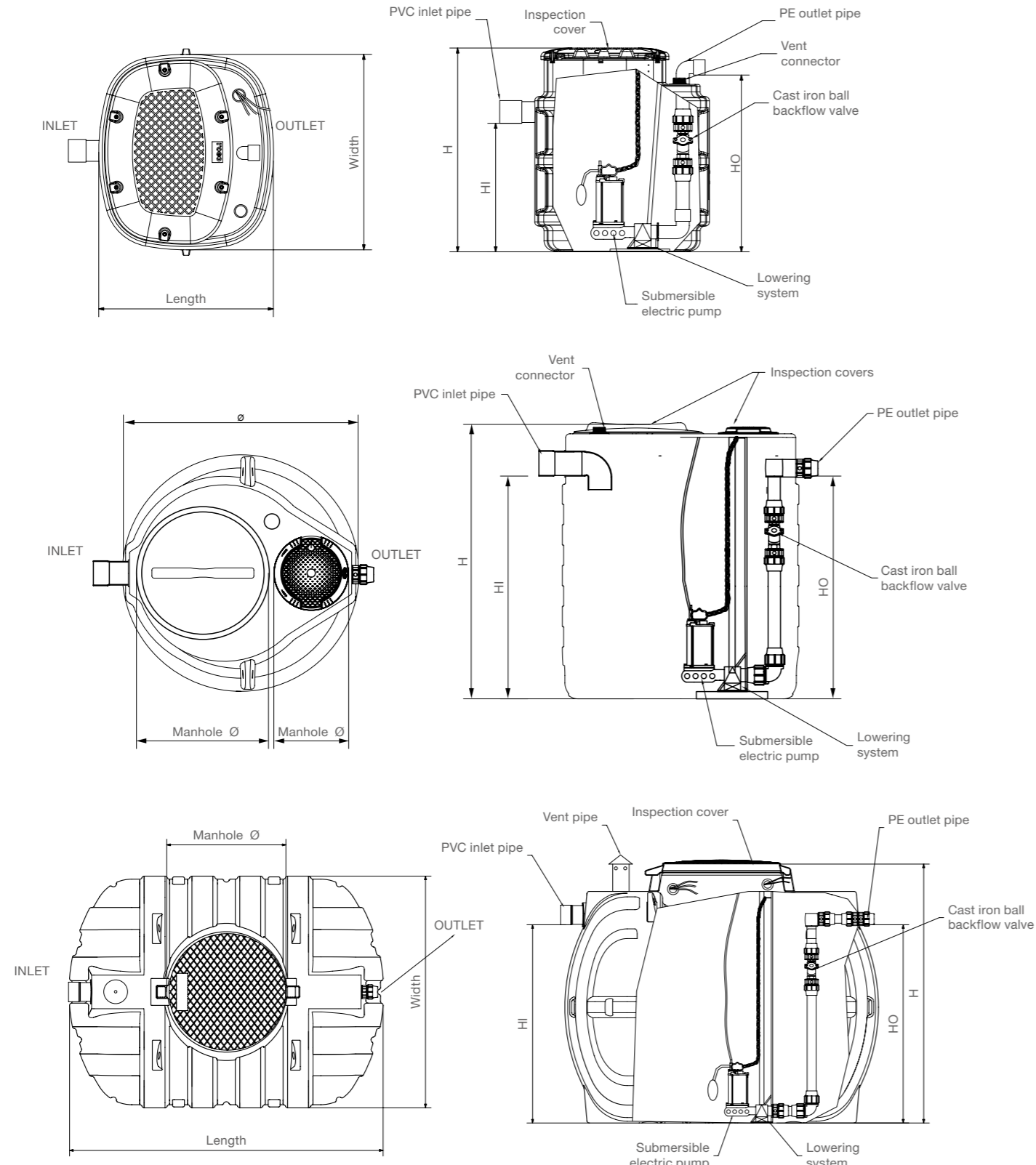

Single and dual-pump lift stations, size 300-3000 l with rapid connection-release-extraction system

Item	Vol. l	Width mm	Length mm	H mm	HI mm	HO mm	Ø I/O mm	Manhole Ø mm	Pump	Impeller type	kW	Flow rate l/min	Head m
TSOL326	300	992	840	836	415	730	110-63	800x570	SM265	Vortex	0.55	0-300	8.5-1
TSOL345	300	992	840	836	415	730	110-63	800x570	SM390	Vortex	0.75	0-500	10.5-1
TSOL363	300	992	840	836	415	730	110-63	800x570	SM635	Two-channel	1.1	0-650	15-0
TSOL312	300	992	840	836	415	730	110-63	800x570	SM125	Grinder	1.18	0-110	30-3
TSOL302	300	992	840	836	415	730	110-63	800x570	PMST2	Grinder	0.9	35-215	16-4
TSOL526	400	992	840	1113	690	1005	110-63	600-300	SM265	Vortex	0.55	0-300	8.5-1
TSOL545	400	992	840	1113	690	1005	110-63	600-300	SM390	Vortex	0.75	0-500	10.5-1
TSOL563	400	992	840	1113	690	1005	110-63	600-300	SM635	Two-channel	1.1	0-650	15-0
TSOL512	400	992	840	1113	690	1005	110-63	600-300	SM125	Grinder	1.18	0-110	30-3
TSOL502	400	992	840	1113	690	1005	110-63	600-300	PMST2	Grinder	0.9	35-215	16-4
TSOL550	400	992	840	1113	690	1005	110-63	600-300	SM590	Vortex	1.5	0-600	15-2
TSOL750	650	992	840	1388	965	1280	110-63	600-300	SM590	Vortex	1.5	0-600	15-2
TSOL726	650	992	840	1388	965	1280	110-63	600-300	SM265	Vortex	0.55	0-300	8.5-1
TSOL745	650	992	840	1388	965	1280	110-63	600-300	SM390	Vortex	0.75	0-500	10.5-1
TSOL763	650	992	840	1388	965	1280	110-63	600-300	SM635	Two-channel	1.1	0-650	15-0
TSOL712	650	992	840	1388	965	1280	110-63	600-300	SM125	Grinder	1.18	0-110	30-3
TSOL702	650	992	840	1388	965	1280	110-63	600-300	PMST2	Grinder	0.9	35-215	16-4
TSOL926	800	992	840	1663	1240	1555	110-63	600-300	SM265	Vortex	0.55	0-300	8.5-1
TSOL945	800	992	840	1663	1240	1555	110-63	600-300	SM390	Vortex	0.75	0-500	10.5-1
TSOL950	800	992	840	1663	1240	1555	110-63	600-300	SM590	Vortex	1.5	0-600	15-2
TSOL963	800	992	840	1663	1240	1555	110-63	600-300	SM635	Two-channel	1.1	0-650	15-0
TSOL912	800	992	840	1663	1240	1555	110-63	600-300	SM125	Grinder	1.18	0-110	30-3
TSOL902	800	992	840	1663	1240	1555	110-63	600-300	PMST2	Grinder	0.9	35-215	16-4

N.B. Filter basket for pump protection is available on request. Compatible with Teknosol lift station with single or double pump 300-800L (see page 154).

Item	Vol. l	Ø mm	H mm	HI mm	HO mm	Ø I/O mm	Manhole Ø mm	Pump	Impeller type	kW	Flow rate l/min	Head m
TSOL1026	1000	1160	1300	1140	1140	125-63	600-300	SM265	Vortex	0.55	0-300	8.5-1
TSOL1045	1000	1160	1300	1140	1140	125-63	600-300	SM390	Vortex	0.75	0-500	10.5-1
TSOL1063	1000	1160	1300	1140	1140	125-63	600-300	SM635	Two-channel	1.1	0-650	15-0
TSOL1012	1000	1160	1300	1140	1140	125-63	600-300	SM125	Grinder	1.18	0-110	30-3
TSOL1002	1000	1160	1300	1140	1140	125-63	600-300	PMST2	Grinder	0.9	35-215	16-4
TSOL1004	1000	1160	1300	1100	1140	160-90	600-300	PMST4	Grinder	1.5	20-245	22-6
TSOL1005	1000	1160	1300	1140	1140	160-90	600-300	PMST5	Grinder	2.2	30-255	28-6
TSOL1526	1300	1160	1500	1300	1300	125-63	600-300	SM265	Vortex	0.55	0-300	8.5-1
TSOL1545	1300	1160	1500	1300	1300	125-63	600-300	SM390	Vortex	0.75	0-500	10.5-1
TSOL1563	1300	1160	1500	1300	1300	125-63	600-300	SM635	Two-channel	1.1	0-650	15-0
TSOL1512	1300	1160	1500	1300	1300	125-63	600-300	SM125	Grinder	1.18	0-110	30-3
TSOL1502	1300	1160	1500	1300	1300	125-63	600-300	PMST2	Grinder	0.9	35-215	16-4
TSOL1504	1300	1160	1500	1300	1300	160-90	600-300	PMST4	Grinder	1.5	20-245	22-6
TSOL1505	1300	1160	1500	1300	1300	160-90	600-300	PMST5	Grinder	2.2	30-255	28-6

Item	Vol. l	Length mm	Width mm	H mm	HI mm	HO mm	Ø I/O mm	Manhole Ø mm	Pump	Impeller type	kW	Flow rate l/min	Head m
TSOL3026	3000	2090	1500	1720	1320	1320	125-50	600-300	SM265	Vortex	0.55	0-300	8.5-1
TSOL3045	3000	2090	1500	1720	1320	1320	125-63	600-300	SM390	Vortex	0.75	0-500	10.5-1
TSOL3063	3000	2090	1500	1720	1320	1320	125-63	600-300	SM635	Two-channel	1.1	0-650	15-0
TSOL3065	3000	2090	1500	1720	1320	1320	125-63	600-300	SM650	Vortex	1.5	0-600	9-3
TSOL3050	3000	2090	1500	1720	1320	1320	160-90	600-300	SM590	Vortex	1.5	0-600	15-2
TSOL3080	3000	2090	1500	1720	1320	1320	160-90	600-300	NRG09	Vortex	2.2	0-700	18-2
TSOL3011	3000	2090	1500	1720	1320	1320	160-90	600-300	SM1100	Vortex	2.2	0-900	13-1
TSOL3012	3000	2090	1500	1720	1320	1320	125-63	600-300	SM125	Grinder	1.18	0-110	30-3
TSOL3002	3000	2090	1500	1720	1320	1320	125-63	600-300	PMST2	Grinder	0.9	35-215	16-4
TSOL3004	3000	2090	1500	1720	1320	1320	160-90	600-300	PMST4	Grinder	1.5	20-245	22-6
TSOL3005	3000	2090	1500	1720	1320	1320	160-90	600-300	PMST5	Grinder	2.2	30-255	28-6

THE PUMPS ARE BOXED AND ARE NOT PRE-INSTALLED IN THE TANK

TEKNOSOL LIFT STATIONS

DUAL PUMP



SEWAGE



WATER



UNDERGROUND INSTALLATION

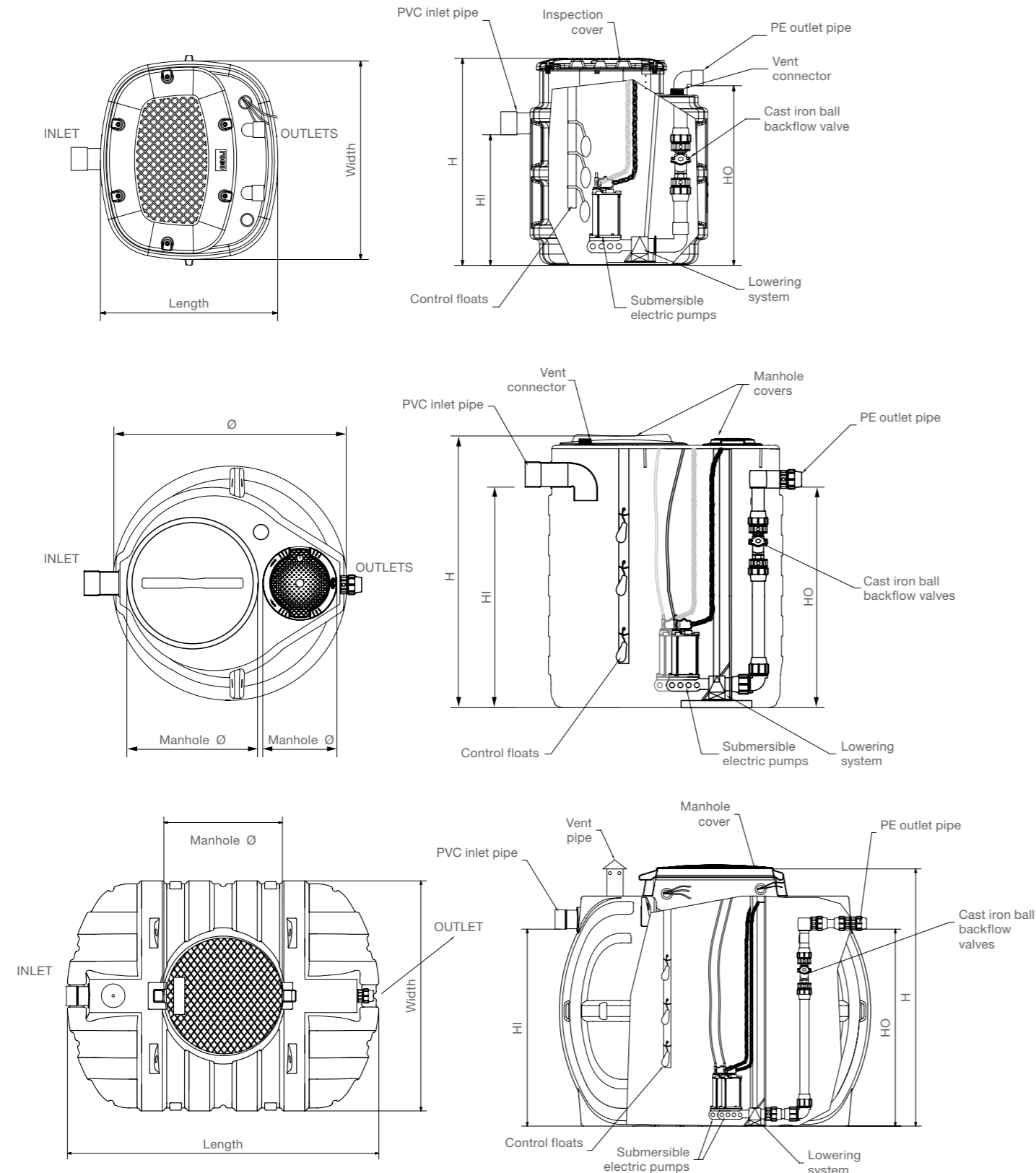

Single and dual-pump lift stations, size 300-3000 l with rapid connection-release-extraction system

Item	Vol. l	Width mm	Length mm	H mm	HI mm	HO mm	Ø I/O mm	Manhole Ø mm	Pump	Impeller type	kW	Flow rate l/min	Head m
TSOL326P2	300	992	840	836	415	730	110-63	800x570	SM265	Vortex	0.55	0-300	8.5-1
TSOL345P2	300	992	840	836	415	730	110-63	800x570	SM390	Vortex	0.75	0-500	10.5-1
TSOL363P2	300	992	840	836	415	730	110-63	800x570	SM635	Two-channel	1.1	0-650	15-0
TSOL312P2	300	992	840	836	415	730	110-63	800x570	SM125	Grinder	1.18	0-110	30-3
TSOL302P2	300	992	840	836	415	730	110-63	800x570	PMST2	Grinder	0.9	35-215	16-4
TSOL526P2	400	992	840	1113	690	1005	110-63	600-300	SM265	Vortex	0.55	0-300	8.5-1
TSOL545P2	400	992	840	1113	690	1005	110-63	600-300	SM390	Vortex	0.75	0-500	10.5-1
TSOL563P2	400	992	840	1113	690	1005	110-63	600-300	SM635	Two-channel	1.1	0-650	15-0
TSOL512P2	400	992	840	1113	690	1005	110-63	600-300	SM125	Grinder	1.18	0-110	30-3
TSOL502P2	400	992	840	1113	690	1005	110-63	600-300	PMST2	Grinder	0.9	35-215	16-4
TSOL550P2	400	992	840	1113	690	1005	110-63	600-300	SM590	Vortex	1.5	0-600	15-2
TSOL750P2	650	992	840	1388	965	1280	110-63	600-300	SM590	Vortex	1.5	0-600	15-2
TSOL702P2	650	992	840	1388	965	1280	110-63	600-300	PMST2	Grinder	0.9	35-215	16-4
TSOL726P2	650	992	840	1388	965	1125	110-63	600-300	SM265	Vortex	0.55	0-300	8.5-1
TSOL745P2	650	992	840	1388	965	1280	110-63	600-300	SM390	Vortex	0.75	0-500	10.5-1
TSOL763P2	650	992	840	1388	965	1280	110-63	600-300	SM635	Two-channel	1.1	0-650	15-0
TSOL712P2	650	992	840	1388	965	1280	110-63	600-300	SM125	Grinder	1.18	0-110	30-3
TSOL926P2	800	992	840	1663	1240	1555	110-63	600-300	SM265	Vortex	0.55	0-300	8.5-1
TSOL945P2	800	992	840	1663	1240	1555	110-63	600-300	SM390	Vortex	0.75	0-500	10.5-1
TSOL950P2	800	992	840	1663	1240	1555	110-63	600-300	SM590	Vortex	1.5	0-600	15-2
TSOL963P2	800	992	840	1663	1240	1555	110-63	600-300	SM635	Two-channel	1.1	0-650	15-0
TSOL912P2	800	992	840	1663	1240	1555	110-63	600-300	SM125	Grinder	1.18	0-110	30-3
TSOL902P2	800	992	840	1663	1240	1555	110-63	600-300	PMST2	Grinder	0.9	35-215	16-4

N.B. Filter basket for pump protection is available on request. Compatible with Teknosol lift station with single or double pump 300-800L (see page 154).

Item	Vol. l	Ø mm	H mm	HI mm	HO mm	Ø I/O mm	Manhole Ø mm	Pump	Impeller type	kW	Flow rate l/min	Head m
TSOL1026P2	1000	1160	1300	1140	1140	125-63	600-300	SM265	Vortex	0.55	0-300	8.5-1
TSOL1045P2	1000	1160	1300	1140	1140	125-63	600-300	SM390	Vortex	0.75	0-500	10.5-1
TSOL1063P2	1000	1160	1300	1140	1140	125-63	600-300	SM635	Two-channel	1.1	0-650	15-0
TSOL1012P2	1000	1160	1300	1140	1140	125-63	600-300	SM125	Grinder	1.18	0-110	30-3
TSOL1002P2	1000	1160	1300	1140	1140	125-63	600-300	PMST2	Grinder	0.9	35-215	16-4
TSOL1004P2	1000	1160	1300	1100	1140	160-90	600-300	PMST4	Grinder	1.5	20-245	22-6
TSOL1005P2	1000	1160	1300	1100	1140	160-90	600-300	PMST5	Grinder	2.2	30-255	28-6
TSOL1526P2	1300	1160	1500	1300	1300	125-63	600-300	SM265	Vortex	0.55	0-300	8.5-1
TSOL1545P2	1300	1160	1500	1300	1300	125-63	600-300	SM390	Vortex	0.75	0-500	10.5-1
TSOL1563P2	1300	1160	1500	1300	1300	125-63	600-300	SM635	Two-channel	1.1	0-650	15-0
TSOL1512P2	1300	1160	1500	1300	1300	125-63	600-300	SM125	Grinder	1.18	0-110	30-3
TSOL1502P2	1300	1160	1500	1300	1300	125-63	600-300	PMST2	Grinder	0.9	35-215	16-4
TSOL1504P2	1300	1160	1500	1300	1300	160-90	600-300	PMST4	Grinder	1.5	20-245	22-6
TSOL1505P2	1300	1160	1500	1300	1300	160-90	600-300	PMST5	Grinder	2.2	30-255	28-6

Item	Vol. l	Length mm	Width mm	H mm	HI mm	HO mm	Ø I/O mm	Manhole Ø mm	Pump	Impeller type	kW	Flow rate l/min	Head m
TSOL3026P2	3000	2090	1500	1720	1320	1320	125-63	600-300	SM265	Vortex	0.55	0-300	8.5-1
TSOL3045P2	3000	2090	1500	1720	1320	1320	125-63	600-300	SM390	Vortex	0.75	0-500	10.5-1
TSOL3063P2	3000	2090	1500	1720	1320	1320	125-63	600-300	SM635	Two-channel	1.1	0-650	15-0
TSOL3065P2	3000	2090	1500	1720	1320	1320	125-63	600-300	SM650	Vortex	1.5	0-600	9-3
TSOL3050P2	3000	2090	1500	1720	1320	1320	160-90	600-300	SM590	Vortex	1.5	0-600	15-2
TSOL3080P2	3000	2090	1500	1720	1320	1320	160-90	600-300	NRG09	Vortex	2.2	0-700	18-2
TSOL3011P2	3000	2090	1500	1720	1320	1320	160-90	600-300	SM1100	Vortex	2.2	0-900	13-1
TSOL3012P2	3000	2090	1500	1720	1320	1320	125-63	600-300	SM125	Grinder	1.18	0-110	30-3
TSOL3002P2	3000	2090	1500	1720	1320	1320	125-63	600-300	PMST2	Grinder	0.9	35-215	16-4
TSOL3004P2	3000	2090	1500	1720	1320	1320	160-90	600-300	PMST4	Grinder	1.5	20-245	22-6
TSOL3005P2	3000	2090	1500	1720	1320	1320	160-90	600-300	PMST5	Grinder	2.2	30-255	28-6

THE PUMPS ARE BOXED AND ARE NOT PRE-INSTALLED IN THE TANK

PUMPS FOR LIFT STATIONS

MULTI-CHANNEL IMPELLER PUMPS

Submersible electric pumps with multichannel open shim impeller. These are ideal to pump clear and turbid water without solid and stringy matter, for example rainwater and treated waste water.



Pump	HP	kW	H	µF	DNM	A mm	B mm	C mm	Weight kg	Flow rate l/min	Head m
PTC4	1	0.75	4.8	20	1" ½	317	57	188	14.5	35-380	12-1
SM635SL	1.5	1.1	7.3	25	2"	466	60	250	19.3	0-650	15-0

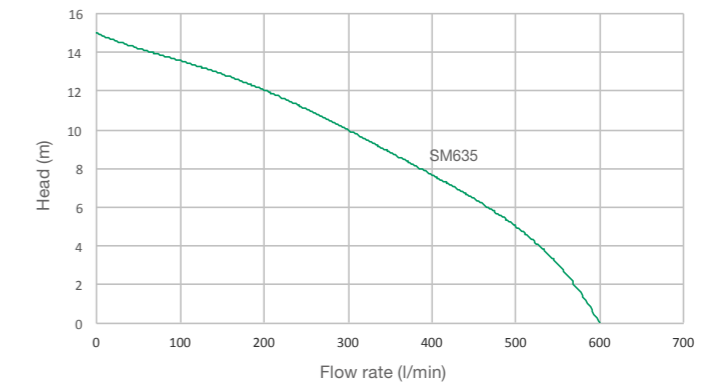
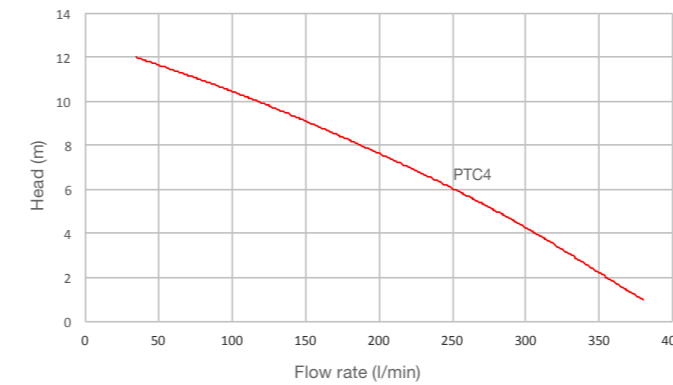

VORTEX IMPELLER PUMPS

Submersible electric pumps with vortex impeller. These are ideal for low head pumping of sewage, including sewage with solid or stringy matter in suspension, such as water from marshy land and untreated domestic sewage.



Pump	HP	kW	H	µF	DNM - Solid passage	A mm	B mm	C mm	Weight kg	Flow rate l/min	Head m
PNRG01	0.4	0.3	2.2	8	1 ¼	263	42	151	9	20-155	6-1
SM265	0.75	0.55	4.2	16	1" ½	400	50	230	16.5	0-300	8.5-1
SM390	1	0.75	5.5	20	2"	435	50	235	18.8	0-500	10.5-1
SM650L	2	1.5	12	31.5	2" ½	445	91	334	22	0-600	9-3
SM590	2	1.5	10.5	31.5	2"	481	50	198	18.2	0-600	15-2
PNRG09 (three-phase)	3	2.2	5.3	-	2"	445	184	232	26	0-700	18-2
PST/65/1100 (three-phase)	3	2.2	6	-	3"	584	65	417	40	0-900	13-1

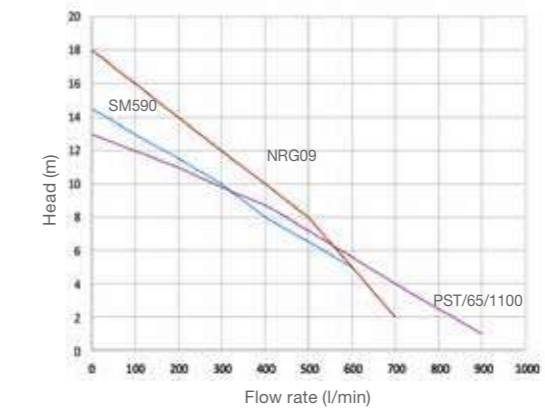
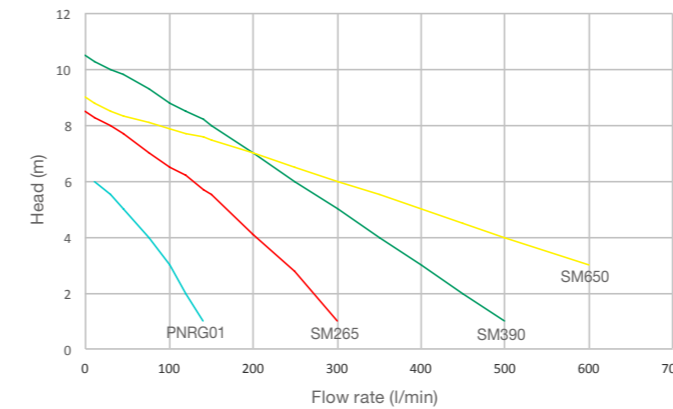

PUMPS WITH GRINDER IMPELLER

Submersible electric pumps with grinder impeller. These are ideal for pumping of sewage, even if it contains with solid or stringy matter in suspension, such as water from marshy land and untreated domestic sewage. Reduction of the solids into small fragments and the high pressure generated by the pump allow considerable differences in level to be overcome.



Pump	HP	kW	H	µF	DNM	A mm	B mm	C mm	Weight kg	Flow rate l/min	Head m
SM125GR	1.6	1.18	9.2	35	1" ½	416	29	240	20.5	0-110	30-3
SM300	1.6	1.18	9.2	35	1" ½	416	46	264	24.5	0-300	0-18
PMST2	1.2	0.9	7.3	30+70	1" ¼	385	78	205	23	35-215	16-4
PMST4	2	1.5	11	40+70	40 mm	442	92	268	38	20-245	22-6
PMST5 (three-phase)	3	2.2	5.3	-	40 mm	442	92	268	40	30-255	28-6

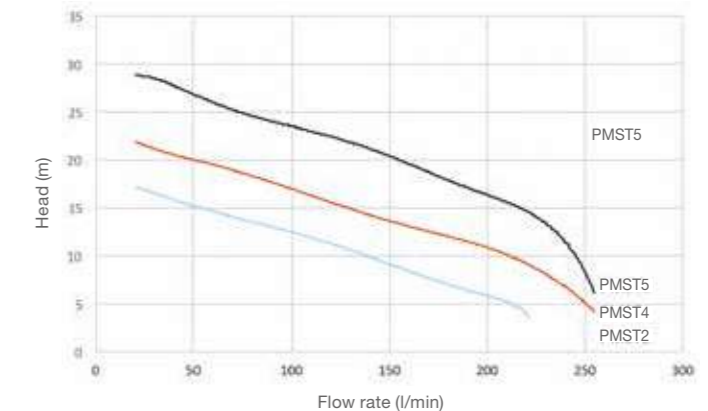
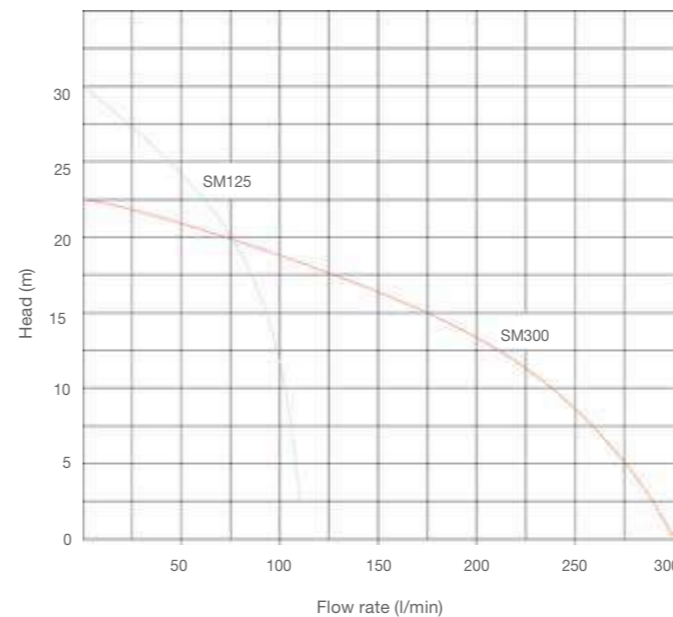

PANELS FOR LIFT STATIONS



SEWAGE



WATER



UNDERGROUND INSTALLATION



DIRECT ELECTRIC PANEL FOR SIMPLE PUMP LIFT STATION (not included)

Item	Power supply V	Pump power		Current		Size			Weight kg
		kW	HP	from (A)	to (A)	Height mm	Length mm	Depth mm	
QCSOLP1	230	0.37-2.2	0.5-3	2	16	340	240	170	1.5
QCSOLP1T	400	0.55-3.7	0.75-5.5	2	8	340	240	170	2

FUNCTION

sewage pump start-up panel for lift station. The start-up command can be either manual or automatic by means of start/stop float switches in the tank. The electric panel is fitted with visual alarms (warning lights) and is set-up for connecting a self-powered audible alarm (mod. QALARM) to signal faults, including in the presence of a power cut. The power supply can be single-phase (domestic type: 230 V) or three-phase (industrial type: 400 V).



ELECTRIC PANEL FOR DUAL PUMP LIFT STATION (not included)

Item	Power supply V	Pump power		Current		Size			Weight kg
		kW	HP	from (A)	to (A)	Height mm	Length mm	Depth mm	
QCSOLP2	230	0.37-2.2	0.5-3	2	16	340	240	170	4
QCSOLP2T	400	0.55-3.7	0.75-5.5	2	8	340	240	170	5.5

FUNCTION

pump start-up panel enabling activation of alternate or simultaneous operation of No. 2 pumps for sewage lift station. The start-up command can be either manual or automatic by means of a series of start-stop float switches positioned at different levels in the tank. The electric panel is fitted with visual alarms (warning lights) and is set-up for connecting an audible alarm (mod. QALARM) to signal faults. The power supply can be single-phase (domestic type: 230 V) or three-phase (industrial type: 400 V).



ALARM UNIT ELECTRIC PANEL (not included)

Item	Power supply V	Size			Weight kg
		Height mm	Length mm	Depth mm	
QALARM	12	160	160	140	0.5
QALARM230	230	160	160	140	0.5

FUNCTION

audible/visual alarm for fault signalling. The unit is set-up for connecting to the electric start-up panels of sewage pumps or to level floats (overflow). For installation in lift stations.



NEW

DIRECT ELECTRIC PANEL FOR SINGLE PUMP LIFT STATION WITH REMOTE MANAGEMENT VIA APP (not included)

Item	Power supply V	Pump power		Current		Size			Weight kg
		KW	HP	from (A)	to (A)	Height mm	Length mm	Depth mm	
QCSOLP1APP	230	0,37-2,2	0,5-3	2	16	340	240	170	1.9
QCSOLP1TAPP	400	0,55-7,5	0,75-10	2	15	340	240	170	2.4

FUNCTION

pump start-up panel for lift station sewage pump. The start-up command can be either manual or automatic by means of start/stop float switches in the tank. The electric panel is fitted with visual alarms (warning lights) and is also set-up for connection of a self-powered audible alarm (mod. QALARM) to signal faults, even in the presence of a power cut. The power supply can be single-phase (domestic type: 230 V) or three-phase (industrial type: 400 V). **The system can be managed using a smart phone or tablet.**

NEW

DIRECT ELECTRIC PANEL FOR DUAL PUMP LIFT STATION WITH REMOTE MANAGEMENT VIA APP (not included)

Item	Power supply V	Pump power		Current		Size			Weight kg
		KW	HP	from (A)	to (A)	Height mm	Length mm	Depth mm	
QCSOLP2APP	230	0,37-2,2	0,5-3	2	16	340	240	170	1.9
QCSOLP2TAPP	400	0,55-7,5	0,75-10	2	15	340	240	170	2.4

FUNCTION

Pump start-up electric panel allowing the activation of alternate or simultaneous operation mode for two sewage pumps serving a lift station. The start-up command can be either manual or automatic by means of a series of start-stop float switches positioned at different levels in the tank. The electric panel is fitted with visual alarms (warning lights) and is also set-up for connection of an audible alarm (mod. QALARM) to signal faults. The power supply can be single-phase (domestic type: 230 V) or three-phase (industrial type: 400 V). **The system can be managed using a smart phone or tablet.**

NEW

ALARM UNIT ELECTRIC PANEL (not included)

Item	Power supply V	Battery autonomy h	Acoustic pressure dB	Size			Weight kg
				Height mm	Length mm	Depth mm	
QALARM230APP	230	24	90	410	240	170	1.8
QALARMTAPP	400	24	90	410	240	170	1.8

FUNCTION

Audible/visual alarm for fault signalling. The unit is set-up for connection to the electric start-up panels of sewage pumps or to level floats (overflow). For installation in lift stations. **SMS and audible/visual alarm.**

ACCESSORIES

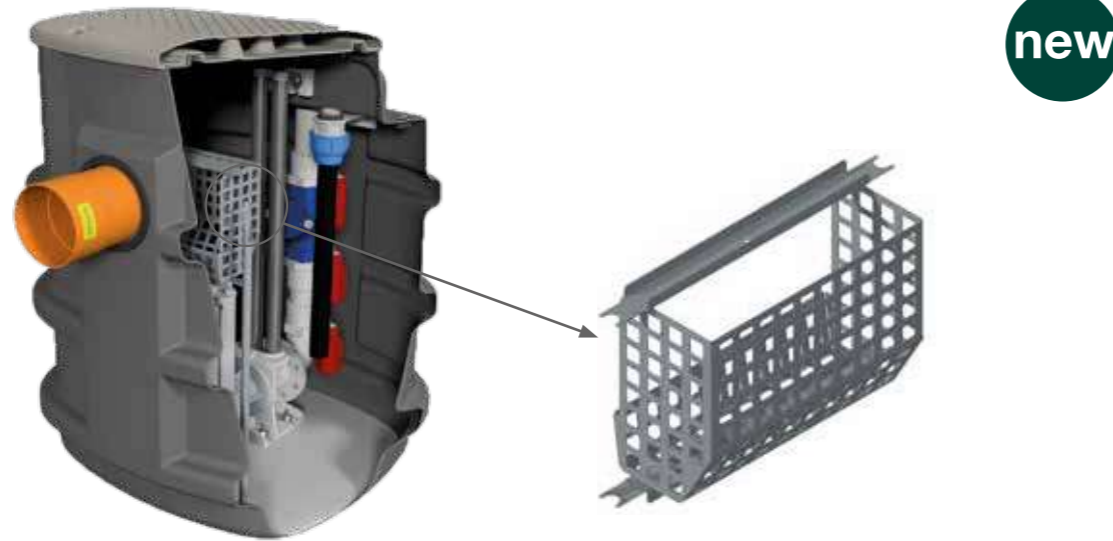

SLIDE-OUT BASKET FOR TEKNOSOL LIFT STATIONS (ON REQUEST)

Item	Impeller type
KCSOL	20 x 20

DESCRIPTION

Internal filter basket specifically designed for Teknosol lift stations, with a capacity of 300 to 800 liters, (single or double pump versions). Positioned at the tank inlet, the accessory acts as a pre-filtration system, capturing coarse solids before they reach the pump. The basket helps protect the pumping unit and increases the reliability of the system, reducing the risk of operational issues caused by solid materials.

FUNCTION

- Interception of coarse solids at the inlet
- Reduction of the risk of pump clogging or blockages
- Protection of the lifting system

TECHNICAL FEATURES

- Internal tank installation
- Positioned at the inlet pipe
- Removable stainless steel filter screen, mesh 20 x 20 mm
- Structure designed for easy removal and reinsertion
- Simple and quick maintenance

COMPATIBILITY

Compatible with Teknosol lift stations, single or double pump, for lifting clear and wastewater, with tank volumes between 300 and 800 liters.

MAINTENANCE

The filter basket should be checked periodically, depending on operating conditions and the type of wastewater handled. The removable screen allows for quick cleaning and easy reinsertion into the tank.

CHAMBERS

SAMPLING CHAMBER

Item	Ø mm	H mm	HI mm	HO mm	I/O Ø mm	Cover Ø mm	Cover	Extensions (optional)
PPF 50	430	465	260	40	125*	300	CC300	PP35
PPF 500	790	790	618	50	125**	400	CC400	PP45

FUNCTION Installation downstream of a sewage treatment plant allows effluent samples to be taken for analysis purposes.

* on request I/O 110 mm
** on request I/O 160 mm

DOSING SIPHON CHAMBER

Item	Ø mm	H mm	HI mm	HO mm	Ø I/O mm	Cover Ø mm	Cover	Extensions (optional)	Dosing siphon volume l
NPDC 500	790	790	640	100	110	400	CC400	PP45	~ 200
NPDC1200	1160	1140	900	150	125 / 110	400	CC400	PP45	~ 670

FUNCTION Essential upstream of a sub-irrigation system with dispersion pipe, for even distribution of the treated effluent along the whole length of the dispersion pipe.

NON-RETURN VALVE / ANTI-RAT CHAMBER

Item	Ø mm	H mm	HI mm	HO mm	Ø I/O mm	Cover Ø mm	Cover	Extensions (optional)
PAR 50	430	430	90	60	125	300	CC300	PP35

FUNCTION When installed on a waste water drain pipe, this stops any backflow from the main sewer and prevents the basement from being flooded. At the same time, the valve prevents animals (e.g. rats) from running up the pipe.

ANTI-FLOODING CHAMBER

Item	Volume l	Ø mm	H mm	HO mm	ØØ mm	Pump	kW	Flow rate l/min	Head m
PDG150	130	660	550	330	50	PNRG01G	0.3	20-155	6-1
PDG300	175	660	700	490	50	PNRG01G	0.3	20-155	6-1

FUNCTION PE chamber with top opening and high-density trafficable PVC grate, containing a pump controlled by an electric float and a PE delivery pipe with non-return valve. The anti-flooding chamber is installed under the floors of garages, basements, and other rooms located below the level of the public sewer system. Its purpose is to collect water and pump it out of the room to prevent sudden flooding caused, for example, by infiltration, accidental pipe breakage, or leaks from household appliances (e.g., washing machines). Water is collected directly through the top grate and discharged by the pump. The chamber's top opening has standard dimensions of 40 x 40 cm and can accommodate cast iron manhole covers.

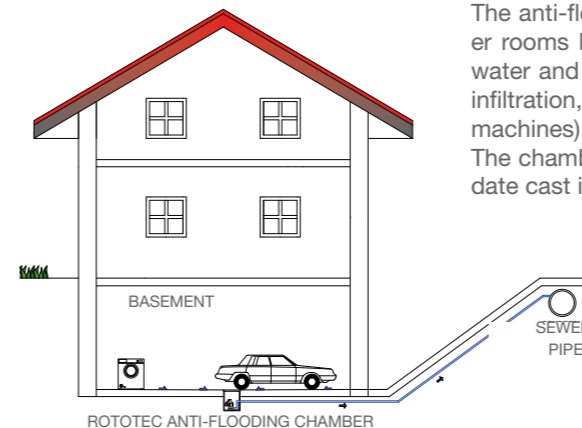
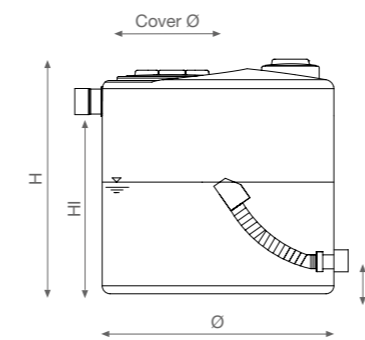



SEWAGE



WATER



UNDERGROUND INSTALLATION



CHAMBERS



SIPHON CHAMBER

Item	Ø mm	H mm	I/O Ø mm	Cover Ø mm	Cover	Extensions (optional)
PSIF 150	582	660	125	300	CC300	PP35

FUNCTION Sewage siphon.

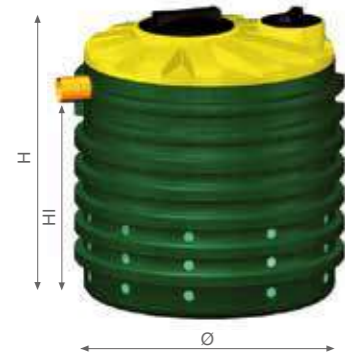

SOAKAWAY CHAMBER

Item	Ø mm	H mm	HI mm	IØ mm	Cover Ø mm	Cover	Extensions (optional)
XPD 1000	1150	1221	930	110	400 - 210	CC400-CC200	PP45 / PP30
XPD 1500	1150	1779	1465	110	400 - 210	CC400-CC200	PP45 / PP30
NPD 2100	1350	1975	1540	110	400 - 300	CC400- CC300	PP45 / PP35
NPD 4000	1710	2150	1850	125	630	TAP800	PP77
NPD 8000	2270	2750	2410	125	630	TAP800	PP77

FUNCTION The holes present on the bottom of the tank allow previously treated effluent to soak away through the surface layers of soil.

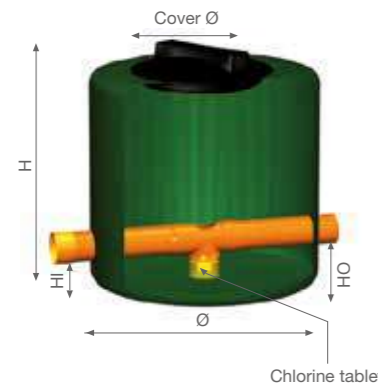

CHLORINATOR CHAMBER

Item	Ø mm	H mm	HI mm	HO mm	Ø I/O mm	Cover Ø mm	Cover	Extensions (optional)
PCL 50	430	430	100	90	110	300	CC300	PP35
PCL 150	580	660	100	90	110	300	CC300	PP35

FUNCTION The chamber has a housing for a chlorine tablet. Consequently, when installed downstream of a treatment plant, it disinfects the final effluent prior to discharging to the receptor.



DOSING CHAMBER

Item	Tank volume l	Ø mm	H mm	Cover Ø mm	Cover	Max. pump flow rate l/h	Working pressure bar	Absorbed power W
PDOS 300	300	630	1100	210	CC200	1	5	32

FUNCTION Dosing sodium hypochlorite (or disinfecting agent) at a constant flow in the disinfection tanks or pipes.

DOSING PUMP

- Plastic container in reinforced PP with protection level IP55;
- Pump body with manual air vent;
- Compact size;
- Fixing bracket for base or wall mounting;
- Operating status signalling with LED;
- Silent version available on request;
- Flow control is by means of frequency variation knob, scale 0-100%.

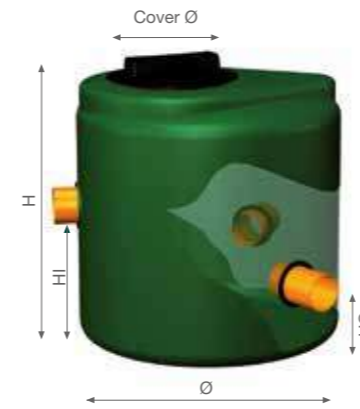

DISTRIBUTION CHAMBER

Item	Ø mm	H mm	Ø I/O * mm	HI mm	HO mm	Cover Ø mm	Cover	Extensions (optional)
PRE 500	790	790	125	to be defined according to use		400	CC400	PP45
PRU 500	790	790	125			400	CC400	PP45

* on request I/O 160 mm and 200 mm

FUNCTION The distribution chambers are installed upstream and downstream of a treatment system laid out in two parallel lines. The upstream chamber divides the effluent into two equal flows, while the downstream chamber combines the two treatment flow lines into one outlet. This latter chamber can also function as a sampling point.

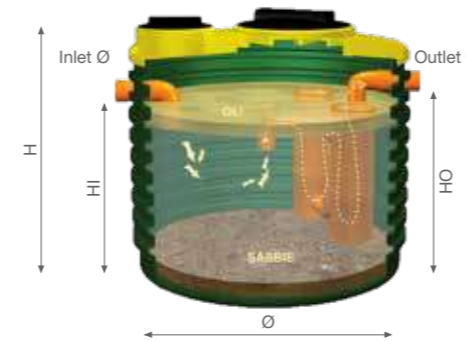

OIL ABSORPTION WELL

Item	Ø mm	H mm	HI mm	HO mm	Ø I/O mm	Useful vol. l
XPOLSS1000	1150	1221	810	790	200	820

FUNCTION A special fabric is present in a removable stainless steel grid. It is able to absorb and block the particles of oil in the effluent. It is used downstream of stormwater treatment systems or oil separators, to block any residual oil that may escape normal treatment.

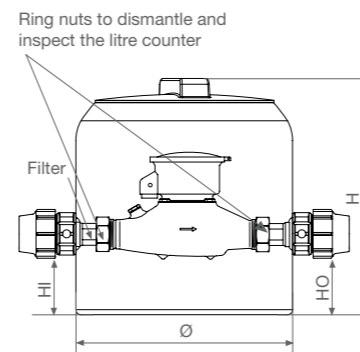

LITRE COUNTER CHAMBER



FUNCTION When installed on a pressurised pipe this allows measurement of the amount of water passing through the pipe itself. It is often required in stormwater run-off systems, downstream of the storage and delivery tank.

Item	Ø mm	H mm	HI mm	HO mm	Cover	Extensions	Bore mm	Max. flow rate m³/h	Nominal flow rate m³/h	Min. flow rate l/h	Sensitivity l/h	Min reading l
PCLT 50	430	430	120	120	CC300	PP 35	32	12	6	120	15	0.05



SEWAGE



WATER



UNDERGROUND INSTALLATION



TECHNICAL SECTION

- p. 160 USE AND MAINTENANCE
- p. 174 TROUBLESHOOTING
- p. 176 SOIL ABSORPTION SYSTEM
- p. 178 CALCULATION OF POPULATION EQUIVALENT
- p. 179 CERTIFICATES

- GREASE SEPARATORS
- IMHOFF BIOLOGICAL TANKS
- BIOLOGICAL SEPTIC TANKS
- ACTIVATED SLUDGE PLANT
- TRICKLE FILTERS
- SECONDARY TREATMENT PLANT
- DEPURBLOK
- DEPURO
- STORMWATER MANAGEMENT
- CAR WASH PLANTS
- LIFT STATIONS
- CHAMBERS
- TECHNICAL SECTION
- UNDERGROUND TANKS
- RAINFALL HARVESTING AND RE-USE SYSTEMS
- CHAMBERS
- PORTABLE TOILETS
- NON-STANDARD SOLUTIONS
- ABOVE-GROUND MODULAR FIREFIGHTING TANKS
- ACCESSORIES
- CONSTRUCTION SITE EQUIPMENT
- OIL DISPOSAL UNIT
- UNDERGROUND INSTALLATION



SEWAGE



WATER

UNDERGROUND
INSTALLATION

GREASE SEPARATORS

TECHNICAL CHARACTERISTICS

The grease separator is a physical pre-treatment process that removes oils, foams, greases and all substances of specific weight less than that of the effluent. Greases and oils produced during normal domestic activities derive from the consumption of butter, margarine, lard and vegetable oils. They also originate from waste meat and vegetables and from some cosmetic products. Greases are insoluble in water and have a low density. In the presence of surface-active agents (detergents), they create stable foams of floating materials that can cause an accumulation of putrescible substances in the sewerage pipes and render oxygenation of the sewage difficult, which also has a detrimental effect on the biological treatment processes located downstream.

The grease separator is nothing more than a stilling tank in which the substances of specific weight less than water are separated by floatation (surface). The reduced velocity of the fluid also allows sedimentation of a part of the suspended solids which deposit at the bottom of the tank. As temperature has a considerable influence on the operation of the grease separator, the separation process becomes 100% effective when the temperature does not rise much above the melting point of the greases, estimated as being around 20°C.

Rototec gravity grease separators consist of a polyethylene tank with two semi-submerged inlet and outlet pipes at different levels. The working volume is divided into three compartments: an inlet zone in which the turbulence of the inlet flow is dampened, a second zone in which the separation takes place together with temporary accumulation of the solids and a third outlet zone for the treated effluent. The longer the retention time of the sewage in the grease separator the more efficient is the removal of the floating materials. This retention time must nevertheless be more than 3 minutes at peak flow. The grease separators are certified in accordance with standard UNI-EN 1825-1 (excluding three-chamber, external and under-sink grease separators) and guarantee a sewage retention time of at least 4 minutes at peak flow Q_{max}, taking into account the available volume only, i.e. that not occupied by greases or heavy sediments. This guarantees retention times at mean daily flow rates of more than 15 minutes.

USE AND MAINTENANCE

The substances removed by floatation accumulate at the surface of the grease separator in the form of a surface crust, while the heavier solids settle at the bottom of the tank to form a deposit of putrescible sludge.

It is advisable to provide for the periodic removal, by specialist staff, of the accumulated materials, which reduce the effective volume required for the passage of the water, reduce the retention time and, as a result, compromise the efficiency of the plant. An excessive accumulation of sludge in the grease separator can cause septic conditions to develop, resulting in resulting bad smells, in particular during the summer.

MANAGEMENT

WHAT TO DO	WHEN	HOW
Inspect the grease separator	Every 1 / 2 months	Unscrew the covers on the inspection holes and check the level of sediment and the surface scum.
Remove the surface scum, the bottom sludge and clean the inlet and outlet pipes	Every 6 / 12 months	Contact a licensed waste disposal company

N.B. the frequency of cleaning operations depends on the amount of oil, grease and solids in the waste.

PROHIBITIONS

- do not use toxic and/or poisonous substances (bleach, solvents, insecticides, disinfectant substances, aggressive detergents), always use biodegradable products;
- NEVER allow rainwater to enter the system.

WARNINGS

- make sure that drains have a siphon;
- check that the pipes slope sufficiently (approximately 1% - 2%);
- connect the biogas vent pipe (see installation method);
- in the case of grey water and sewage flowing into the same pipe, DO NOT install the grease separator, but an Imhoff septic tank one class higher than that for the Population Equivalent (P.E.) number;
- after emptying, fill the tank again with clean water;
- in the event of a maintenance operation of any kind, always comply with the safety regulations regarding operations within closed waste water treatment areas, and with the general technical procedures applicable
- products in PE manufactured using rotational moulding can have the following tolerances:
+/- 3% on dimensions and +/- 5% on capacity

IMHOFF BIOLOGICAL TANKS

TECHNICAL CHARACTERISTICS

A series of chemical, physical and biological processes take place inside the biological septic tank, allowing a reduction in the values of the main reference parameters (BOD₅, COD, SS (Suspended Solids)). More specifically, the Imhoff cone means that the turbulence of the inlet flow is dampened in the upper sedimentation section, with solids tending to settle and enter the lower digestion section. In the same way, any substances with a specific weight lower than that of water (e.g. oils and greases, foam,...) separate from the effluent and accumulate on the surface. In the digestion section, in a completely anaerobic environment, the bacterial flora developed and maintained partially digests the accumulated sludge, transforming it into more stable, non-polluting products. The Imhoff biological tank must be installed directly on the sewage line. It is good practice to install a grease separator tank for the pre-treatment of grey water from bathroom and kitchen sinks, showers, bidets, etc.

USE AND MAINTENANCE

From the moment the Imhoff is put into operation, the anaerobic bacterial flora starts to develop inside the tank. Obviously, a certain period of time is necessary in order to reach the correct balance and maximum treatment efficiency. This is known as the start-up phase, and can last between 2 and 5 weeks. To reduce this time, the use of a specific bio-activator is recommended. An excessive accumulation of sedimentable material in the sludge compartment can cause uncontrolled anaerobic digestion phenomena, leading to an over-production of biogas and bad smells. Furthermore, the reduction in the volume available in the digestion compartment and the excessive production of gas bubbles will cause the settled material to rise, causing deterioration in the quality of the treated effluent. The use of the Rototec BIO-ACTIVATOR is highly recommended for rendering the initiation of the biological processes more rapid, thus limiting the number of sludge removal operations and reducing the risk of malodorous emissions. The DEPURO NIM Imhoff tank is designed to provide primary and secondary recirculation sludge storage for a period of 6-8 months of plant operation. A minimum of 1-2 inspections per year by qualified personnel and eventual emptying operations must be programmed according to the loads fed to the tank. Once the settled sludge has been removed, the internal surfaces of the tank must be cleaned in order to eliminate any material obstructing the effluent inlet and outlet pipes and the outlet of the sedimentation chamber.

MANAGEMENT

WHAT TO DO	WHEN	HOW
Inspect the Imhoff biological tank	From 1 to 2 times a year	Unscrew the inspection covers and check the level of sediments
Remove the settled sludge, clean the interior and the inlet and outlet pipes	Every 6 / 12 months	Contact a licensed waste disposal company

N.B. the frequency of operations will depend on the incoming organic load.

PROHIBITIONS

- do not use toxic and/or poisonous substances (bleach, solvents, insecticides, disinfectant substances, aggressive detergents), always use biodegradable products;
- NEVER flush paper tissues, kitchen towel, paper napkins or other materials except toilet paper down the toilet;
- NEVER allow rainwater to enter the system.

WARNINGS

- make sure that drains have a siphon;
- check that the pipes have sufficient gradient (approximately 1% - 2%);
- connect the biogas vent pipe (see underground installation);
- after emptying, fill the tank again with clean water;
- in the event of a maintenance operation of any kind, always comply with the safety regulations regarding operations within enclosed wastewater treatment areas and with the general technical procedures applicable within enclosed wastewater treatment areas and with the general technical procedures applicable.



SEWAGE



WATER

UNDERGROUND
INSTALLATION

BIOLOGICAL SEPTIC TANKS

TECHNICAL CHARACTERISTICS

Septic tanks constitute a reliable device for the primary treatment of sewage. The treatment systems are passive, extremely stable, simple and inexpensive. They are used, above all, for treating domestic sewage from small communities. The configuration of the tank forces the sewage to pass through the liquid mass contained in it. The slowing down of the flow allows sedimentable solids and substances of specific weight less than that of the water to separate. Furthermore, an anaerobic fermentation process is triggered with the resulting solubilisation and synthesis of part of the suspended solids. In this way, the effluent leaving the tank is conditioned, i.e. it has a limited concentration of solids, transformed for the most part into dissolved and colloidal solids.

Septic tanks are nothing more than stilling tanks in which the following processes take place:

- separation of sedimentable solids, coarse material, sand/grit, oils and greases present in the sewage;
- reduction of a fraction of the accumulated organic substances by decomposition;
- accumulation and prolonged storage of the separated materials.

Compartmentation, i.e. the division of the system into chambers, significantly influences the efficiency of the treatment process. With this configuration, a large part of the suspended solids accumulate in the first compartment and only pass to the next chamber with great difficulty. Compartmentation is particularly effective when high levels of treatment are to be reached, particularly in terms of reducing suspended solids. The volumes of septic tanks are calculated to achieve high treatment performance and to obtain liquefaction of the sludge, which reduces its production and thus minimises the cost of disposal. For populations of up to 50 P.E., the sizing, which is not applicable to new installations in which a minimum retention time of 12 hours is required for the daily flow discharged (150-200 l/P.E.) and at least 50 l pro capita for the sludge storage, for a total of 125-150 l/P.E. The single-chamber septic tanks are certified under standard UNI EN 12566-1. The septic tank is only foreseen when replacing existing systems. Some local authorities, however, still prescribe the installation of two-chamber and three-chamber septic tanks.

USE AND MAINTENANCE

An excessive accumulation of putrescible material at the bottom of the tank can cause uncontrolled anaerobic digestion phenomena, leading to an over-production of biogas and the development of malodorous emissions. Furthermore, the reduction in the volume available in the digestion compartment and the excessive production of gas bubbles will cause the settled material to rise, thus causing deterioration in the quality of the treated effluent.

For this reason, according to the loads feeding the tank, between 1 and 4 inspections a year are to be foreseen, with removal of the sludge if necessary. It is sometimes recommended not to remove all the deposited sludge, but to leave approximately 1/10 of the sludge that has deposited in the tank; this accelerates re-start of the processes. The use of the Rototec Bioactivator is highly recommended to trigger the biological processes more quickly, thus limiting the number of sludge removal operations and reducing the risk of bad smells.

MANAGEMENT

WHAT TO DO	WHEN	HOW
Inspect the septic tank	From 1 to 4 times a year	Unscrew the covers on the inspection holes and check the level of sediments
Extract the bottom sludge, clean the interior and the inlet and outlet pipes	Every 6 / 12 months	Contact a licensed waste disposal company

N.B. the frequency of operations will depend on the incoming organic load.

PROHIBITIONS

- do not use toxic and/or poisonous substances (bleach, solvents, insecticides, disinfectant substances, aggressive detergents), always use biodegradable products;
- NEVER flush paper tissues, kitchen towel, paper napkins or other materials except toilet paper down the toilet;
- NEVER allow rainwater to enter the system.

WARNINGS

- make sure that drains have a siphon;
- check that the pipes slope sufficiently (approximately 1% - 2%);
- connect the biogas vent pipe (see installation method);
- after emptying, fill the tank again with clean water;
- in the event of a maintenance operation of any kind, always comply with the safety regulations regarding operations within closed waste water treatment areas, and with the general technical procedures applicable.
- products in PE manufactured using rotational moulding can have the following tolerances:
 - +/- 3% on dimensions and +/- 5% on capacity

ACTIVATED SLUDGE PLANTS

(LOW LOAD, TOTAL OXIDATION, IFABLOK)

TECHNICAL CHARACTERISTICS

Activated sludge plants are secondary treatment systems that make use of the action of the bacterial colonies that, remaining in suspension in the sewage, consume the biodegradable organic material, using it as a nutrient to obtain the necessary energy and the material required for the synthesis of new cells. In this manner, increasingly stable compounds are formed leading to the total degradation of the organic load. Very high concentrations of aerobic type bacteria are developed inside activated sludge plants, sufficient, that is, to absorb the dissolved oxygen in the water in order to consume the biodegradable material. To guarantee the concentration of oxygen necessary for the development of the biological reaction, an aeration system is adopted consisting of submerged diffusers which, from the bottom of the tank, disperse a flow of fine air bubbles. This also guarantees sufficient mixing to keep the high concentrations of solids present in the tank in suspension.

In the oxygen rich environment of the aeration tank, a number of different processes are set in motion:

- Chemical, i.e. the oxidation of malodorous compounds (hydrogen sulphide, sulphites...)
- Physical, i.e. the removal of sewage solids trapped by the dispersion of bacteria
- Biological, i.e. direct assimilation of the organic substances dissolved in the sewage.

The sizing of the activated sludge plants is performed on the basis of the sludge load (or organic load factor) expressed as the ratio between the organic load BOD5 and the micro-organisms; the lower this ratio, the more intensely the organic load is consumed, at the same time reducing the production of excess sludge. Rototec activated sludge plants are sized to have sludge loads of less than 0.08 KgBOD/KgSSD with retention times of more than 24 hours at mean flows and volumetric loads of less than 0.25 KgBOD/m3d in the prolonged aeration (or total oxidation) configuration and sludge loads of less than 0.15 KgBOD/KgSSD and volumetric loads less than 0.5 KgBOD/m3d in the low-load configuration.

USE AND MAINTENANCE

The small user activated sludge plant is designed with the sedimentation compartment inside the oxidation tank in order to provide sewage settlement as well as sludge recirculation. This however leads to a build-up of solids in the oxidation chamber. Cleaning operations are carried out by qualified personnel as part of the Imhoff tank inspection and emptying operations. It should be remembered that in order to ensure the correct operation of a low-load activated sludge plant, a grease separator and Imhoff tank or similar should be installed upstream of the reactor itself, and that the aeration should be kept on during the periods of use of the plant. The plant needs 10-15 days in order to reach normal operation. This time can be reduced, however, by adding biomass activators (Rototec bioactivator) directly to the sewage.

MANAGEMENT

WHAT TO DO	WHEN	HOW
Inspect the activated sludge plant	Every 6 / 12 months	Unscrew the covers on the inspection holes and check the level of sediments
Check operation of the blower	Every month	Unscrew the inlet manhole cover and check the air being blown into the tank
Extract the bottom sludge, clean the interior, the inlet and outlet pipes and the diffuser plate	Every 6 / 12 months	Contact a licensed waste disposal company
Replace the chlorine tablet (when required)	Every 2 months	Unscrew the outlet manhole cover and place the tablet in the housing provided

N.B. the frequency of operations will depend on the incoming organic load.

PROHIBITIONS

- do not use toxic and/or poisonous substances (bleach, solvents, insecticides, disinfectant substances, aggressive detergents), always use biodegradable products;
- NEVER put the chlorine tablet into the plant, but insert it in the proper housing;
- NEVER allow rainwater to enter the system.

WARNINGS

- make sure that drains have a siphon;
- check that the pipes slope sufficiently (approximately 1% - 2%);
- connect the biogas vent pipe (see installation method);
- when discharging into the subsoil using a soil absorption system, provide a dosing siphon chamber downstream of the system, for better distribution of the effluent into the dispersion pipes;
- after emptying, fill the tank again with clean water;
- in the event of a maintenance operation of any kind, always comply with the safety regulations regarding operations within closed waste water treatment areas, and with the general technical procedures applicable.
- products in PE manufactured using rotational moulding can have the following tolerances:
 - +/- 3% on dimensions and +/- 5% on capacity

ACTIVATED SLUDGE PLANTS

ACCESSORIES INCLUDED IN THE SUPPLY

BLOWER/COMPRESSOR

Rototec fits its activated sludge plants with diaphragm type air compressors which make use of the electromagnetic vibration of an actuator rod supported by rubber diaphragms. This system reduces energy consumption to a minimum by supplying constant air flows without any variations in working pressure. The blower does not have any moving parts in contact, and as such does not require any lubrication. Special attention is paid to the acoustic insulation and to the design of the vibrating section of the compressor in order to make it as silent as possible.



SIDE CHANNEL BLOWER

Compressors-aspirators constructed in accordance with the side channel principle, operating both in aspiration and in compression. They are designed to operate continuously. Constructed in die-cast aluminium to guarantee maximum sturdiness and ease of handling. Special silencers contribute to its extremely low noise levels.

INSTALLATION

- install in a special above ground technical room (with an environment free from corrosive gas), protected from the weather but with adequate ventilation to avoid overheating of the blower;
- maximum distance of 10 m from the activated sludge plant;
- the blower must rest on a stable, flat surface, not exposed to vibration, at a level higher than that of the plant itself so as to avoid any return of the sludge if the air supply is interrupted;
- if necessary, provide ducting for the air pipe, running from the technical room to the edge of the tank (minimum diameter 80mm), and for the electric cable (minimum diameter 63mm);
- connect one end of the air feed pipe supplied to the outlet of the blower using the appropriate clips;
- connect the other end of the pipe to the coupling on the tank;
- when installation has been completed, connect the blower to the power socket (220V, 50Hz).

MANAGEMENT

WHAT TO DO	WHEN	HOW
Check the operation of the blower	Every month	Unscrew the inlet manhole cover and check the air being blown into the tank
Clean the suction filter (membrane model)	Every 3 months	Remove the filter, eliminate excess dust and if necessary wash with mild detergent

PROHIBITIONS

- do not connect the compressor to a power supply other than that specified. If there is any doubt about the connections, DO NOT connect up the equipment.

WARNINGS

- the operating temperature must be between -20°C and $+40^{\circ}\text{C}$ with relatively low humidity;
- carry out all cleaning and/or part replacement operations with the power supply disconnected;
- before carrying out any cleaning and/or part replacement operations, in order to avoid risks of burning, make sure that the compressor has cooled down sufficiently;
- when carrying out repairs, in order to guarantee the safety of the equipment, it is good practice to use original spare parts only;
- maintenance operations requiring the presence of electricity, such as troubleshooting the blower, must be carried out by qualified personnel.

PLATE/TUBULAR/MEMBRANE DIFFUSERS

In its activated sludge plants, Rototec uses diaphragm type diffusers in microbored rubber, constructed to provide a uniform distribution of air with bubbles of microscopic diameter designed to optimise the oxygenation of the effluent. The particular structure of the plates reduces the risk of blockages even during intermittent operation to a minimum and eliminates the possibility of its separation during the inspection phase, thus guaranteeing a high air flow with minimum head loss. The rubber lining of the rigid air distributor provides protection against accidental damage to the system, which will maintain its original characteristics over time. The innovative composition of the plate also ensures absolute impermeability of the connection between the diaphragm, the support plate and the support coupling.



INSTALLATION

- already fitted inside the tank and connected to the set-up provided;
- stays on the bottom of the tank thanks to its special micro-pore rubber structure.

MANAGEMENT

WHAT TO DO	WHEN	HOW
Clean the diffuser	During cleaning of the plant (every 6/12 months)	Contact a licensed waste disposal company (water jet pump-out)

WARNINGS

- during cleaning operations, lift the plate using the transparent pipe provided, paying attention to the set-up in the tank.





SEWAGE



WATER

UNDERGROUND
INSTALLATION

TRICKLE FILTERS

TECHNICAL CHARACTERISTICS

A trickle filter is a biological reactor, inside which the micro-organisms that purify the effluent develop on the surface of special bulk fill material (filter media). The uniform distribution of the effluent through the filter guarantees maximum contact between the organic material to purify and the biological film covering the spheres making up the fill material.

The spheres of the filter media are manufactured in polypropylene and are designed to provide a large surface area available for bacterial micro-organisms to take root. In particular, the spheres used provide a surface area per unit volume of filter media of 140 m²/m³, much higher than the traditional stone fill material, with voids accounting for over 90% of the volume. This solution minimises the risk of clogging the bed and also guarantees an improved circulation of air through the bed of the aerobic filter. Trickle filters allow good purification performance without any energy overheads, with management costs limited to periodic cleaning of the plant.

The sizing of trickle filters for an average domestic effluent refers to the organic load factor (kgBOD/m³d) with which the filter is fed. This parameter is the ratio between the organic load at the inlet (kg BOD₅d) and the volume of the filter bed. Rototec filters are designed to operate with medium-low organic load factors (kg BOD₅/m³d). This guarantees a good margin of safety, with respect to fluctuations in inlet flow, and a limited production of excess sludge.

USE AND MAINTENANCE

The filter is designed to ensure minimum clogging risk. However, the development of the films on the bulk fill material can over time excessively dirty the filter, with the resulting risk of solids being discharged with the treated effluent.

Cleaning operations are normally carried out as part of the Imhoff tank inspection and emptying operations. It should be remembered that in order for the trickle filter to function correctly, the effluent must first be subjected to sedimentation treatment in an Imhoff tank or similar installed upstream of the filter. The use of Rototec Bioactivators is recommended to speed up the start of the biological processes.

MANAGEMENT

WHAT TO DO	WHEN	HOW
Inspect the trickle filter	Every 12 months	Unscrew the covers on the inspection holes and check the level of sediments
Extract the bottom sludge, clean the interior and the inlet and outlet pipes and backwash the filter media	Every 12/15 months	Contact a licensed waste disposal company

N.B. the frequency of operations will depend on the incoming organic load.

PROHIBITIONS

- do not use toxic and/or poisonous substances (bleach, solvents, insecticides, disinfectant substances, aggressive detergents), always use biodegradable products.
- NEVER allow rainwater to enter the system.

WARNINGS

- make sure that drains have a siphon;
- check that the pipes slope sufficiently (approximately 1% - 2%);
- connect the biogas vent pipe (see installation method).
- when discharging to a surface watercourse, install a septic tank (Imhoff or other septic tank) downstream of the trickle filter as the final effluent sedimentation and clarification phase;
- when discharging into the subsoil using a soil absorption system, provide a dosing siphon chamber downstream of the system, for better distribution of the effluent into the dispersion pipes;
- the outlet from the trickle filter is level with the bottom of the element, and as such in the absence of any difference in level, the installation of a lifting system downstream of the filter itself is required;
- after emptying, fill the tank again with clean water;
- in the event of a maintenance operation of any kind, always comply with the safety regulations regarding operations within closed waste water treatment areas, and with the general technical procedures applicable;
- products in PE manufactured using rotational moulding can have the following tolerances:
 - +/- 3% on dimensions and +/- 5% on capacity

TOP OUTLET AEROBIC TRICKLE FILTERS

TECHNICAL CHARACTERISTICS

A top outlet aerobic trickle filter is a biological reactor, inside which the micro-organisms that purify the effluent develop on the surface of special bulk fill material (filter media). The uniform distribution of the effluent through the filter guarantees maximum contact between the organic material to purify and the biological film covering the spheres making up the fill material. More specifically, the bacteria that grows and develops inside the aerobic trickle filter with top outlet consumes the organic load in the effluent in the presence of oxygen, continually entering the tank through the external compressor and distributed by the diffuser plates.

The spheres of the filter media are manufactured in polypropylene and are designed to provide a large surface area available for bacterial micro-organisms to take root. In particular, the spheres used provide a surface area per unit volume of filter media of 140 m²/m³, much higher than the traditional stone fill material, with voids accounting for over 90% of the volume. This solution minimises the risk of clogging the bed and also guarantees an improved circulation of air through the filter bed. Top outlet aerobic trickle filters with blower are used as secondary treatment of domestic effluent and the like. They must be preceded by a grease separation phase and a primary sedimentation phase (Imhoff or septic tank) in order to be able to discharge the treated effluent to a soil absorption system or to a surface watercourse.

The sizing of trickle filters for an average domestic effluent refers to the organic load factor (kgBOD/m³d) with which the filter is fed. This parameter is the ratio between the organic load at the inlet (kg BOD₅d) and the volume of the filter bed. Rototec filters are designed to operate with medium-low organic load factors (kg BOD₅/m³d). This guarantees a good margin of safety, with respect to fluctuations in inlet flow, and a limited production of excess sludge.

USE AND MAINTENANCE

The filter is designed to ensure minimum clogging risk. However, the development of the films on the bulk fill material can over time excessively dirty the filter, with the resulting risk of solids being discharged with the treated effluent. Cleaning operations are normally carried out as part of the Imhoff tank inspection and emptying operations. It should be remembered that in order for the trickle filter to function correctly, the effluent must first be subjected to sedimentation treatment in an Imhoff tank or similar installed upstream of the filter. It should be remembered that the aeration process must be kept active while the plant is in service. The plant needs 10-15 days in order to reach normal operation. This time can be reduced, however, by adding biomass activators (Rototec bioactivator) directly to the sewage.

MANAGEMENT

WHAT TO DO	WHEN	HOW
Inspect the trickle filter	Every 12 months	Unscrew the covers on the inspection holes and check the level of sediments
Check operation of the blower	Every month	Unscrew the inlet manhole cover and check the air being blown into the tank
Extract the bottom sludge, clean the interior, the inlet and outlet pipes and the diffuser plate, backwash the bulk fill material	Every 12/15 months	Contact a licensed waste disposal company

N.B. the frequency of operations will depend on the incoming organic load.

PROHIBITIONS

- do not use toxic and/or poisonous substances (bleach, solvents, insecticides, disinfectant substances, aggressive detergents), always use biodegradable products;
- NEVER allow rainwater to enter the system.

WARNINGS

- make sure that drains have a siphon;
- check that the pipes slope sufficiently (approximately 1% - 2%);
- connect the biogas vent pipe (see installation method);
- when discharging into the subsoil using a soil absorption system, provide a dosing siphon chamber downstream of the system, for better distribution of the effluent into the dispersion pipes;
- after pump-out, fill the tank again with clean water;
- in the event of a maintenance operation of any kind, always comply with the safety regulations regarding operations within closed waste water treatment areas, and with the general technical procedures applicable;
- products in PE manufactured using rotational moulding can have the following tolerances:
 - +/- 3% on dimensions and +/- 5% on capacity

SECONDARY TREATMENT

TECHNICAL CHARACTERISTICS

Secondary treatments consisting of an anaerobic trickle filter and an activated sludge plant allow almost 100 % removal of the organic load and suspended solids with a very high reduction in the nitrogen load and phosphorous load found in domestic sewage.

The trickle filter is a biological reactor in which the micro-organisms, under anaerobic conditions, make use of the biodegradable substance contained in the effluent. These micro-organisms develop on the surface of special bulk fill material in polypropylene, specifically designed to maximise the contact surface area between the micro-organisms and the effluent. Activated sludge plants are systems in which the bacterial flora develops in colonies that remain in suspension in the effluent and consume the remaining biodegradable material. The process is fully aerobic and the oxygen necessary for the development of the bacteria is supplied by submersed diffusers that emit a flow of fine bubbles of air from the bottom of the tank. This also guarantees continuous effluent mixing.

The outlet from the activated sludge plant is equipped with a housing in which it is possible to insert a chlorine tablet. This allows the effluent leaving the treatment plant to be disinfected.

USE AND MAINTENANCE

Bacterial organisms develop inside the two tanks forming the treatment system and transform the pollutants into inert sludge which tends to accumulate at the bottom and on the filter media of the trickle filter. Over time, an excessive accumulation of sludge leads to the release of these bacterial organisms with the resulting deterioration in the quality of the final effluent. For this reason, the tanks need to be inspected and subjected to periodic maintenance. These operations are normally carried out as part of the Imhoff tank inspection and emptying operations.

During the tank inspection operations, make sure that there is a continuous supply of air being blown into the activated sludge plant. It should be remembered that in order for the plant to function correctly, the effluent must first be subjected to grease separation and sedimentation treatment in an Imhoff tank or similar installed upstream of the system.

The plant needs 10-15 days in order to reach normal operation. This time can be reduced, however, by adding biomass activators (Rototec Bioactivator) directly to the sewage.

PROHIBITIONS

- do not use toxic and/or poisonous substances (bleach, solvents, insecticides, disinfectant substances, aggressive detergents), always use biodegradable products;
- NEVER put the chlorine tablet into the activated sludge plant, but insert it in the proper housing;
- NEVER allow rainwater to enter the system.

WARNINGS

- make sure that drains have a siphon;
- check that the pipes slope sufficiently (approximately 1% - 2%);
- connect the biogas vent pipe in both tanks (see installation method);
- after pump-out, fill the tanks again with clean water;
- in the event of a maintenance operation of any kind, always comply with the safety regulations regarding operations within closed waste water treatment areas, and with the general technical procedures;
- products in PE manufactured using rotational moulding can have the following tolerances:
 - +/- 3% on dimensions and +/- 5% on capacity

WARNINGS (blower)

- the operating temperature must be between -20°C and +40°C with relatively low humidity;
- carry out all cleaning and/or part replacement operations with the power supply disconnected;
- before carrying out any cleaning and/or part replacement operations, in order to avoid risks of burning, make sure that the compressor has cooled down sufficiently;
- when carrying out repairs, in order to guarantee the safety of the equipment, it is good practice to use original spare parts only;
- maintenance operations requiring the presence of electricity, such as troubleshooting the blower, must be carried out by qualified personnel.
- never connect the compressor to energy sources other than those indicated. If there is any doubt about the connections, DO NOT connect the equipment.

MANAGEMENT

WHAT TO DO	WHEN	HOW
Inspect the activated sludge plant	Every 6 / 12 months	Unscrew the covers on the inspection holes and check the level of sediments
Inspect the trickle filter	Every 6 / 12 months	Unscrew the covers on the inspection holes and check the level of sediments
Check the operation of the blower	Every month	Unscrew the cover on the inlet manhole and check that air is being blown into the activated sludge plant
Clean the blower suction filter	Every 3 months	Remove the filter, eliminate excess dust and if necessary wash with mild detergent
Extract the bottom sludge, clean the interior and the inlet and outlet pipes	Every 6 / 12 months	Contact a licensed waste disposal company
Clean the plate diffuser in the activated sludge plant	Every 6 / 12 months	Contact a licensed waste disposal company (water jet pump-out)
Backwash the filter media in the trickle filter	Every 6 / 12 months	Contact a licensed waste disposal company (water jet pump-out)

N.B. the frequency of operations will depend on the incoming organic load.



SEWAGE



WATER



UNDERGROUND INSTALLATION



COALESCING FILTER OIL SEPARATORS

(INCLUDING MODELS WITH INTEGRATED BY-PASS)

TECHNICAL CHARACTERISTICS

Oils and greases are present in most industrial effluents. Their removal is necessary prior to discharge due to the negative aesthetic effects that they produce when discharged to a body of surface water and due to the damage caused to flora and fauna. Furthermore, their removal is also necessary as a pre-treatment prior to any other treatment phase, in that they create problems for the development of the biological treatment processes.

In the case of service stations, car washes, workshops and parking areas, the oils and greases are essentially of mineral type and non-biodegradable, including in the long-term. Consequently, the discharge of these substances into the sewerage system or worse still into watercourses or the soil have even more negative consequences, not only because of the risk of causing blockages, but because they cannot be degraded at all by the environment. To remove this type of pollutants, coalescing filter type oil separators are used when the final outlet is to a watercourse or soak-away system. These oil separators are defined as class I under UNI-EN 858-1.

Oil separators with coalescing filters allow improved performance to be obtained in removing light substances. The system makes use of a polyurethane sponge support on which the oil and hydrocarbon particles collect until their dimensions are such that enable them to settle away from the effluent by gravity. This treatment is recommended in the presence of particularly severe limitations on the discharged concentrations of mineral oils and hydrocarbons. It is advisable to install a grit separator upstream of the oil separator in order to prevent solid particles from clogging the filter meshes.

USE AND MAINTENANCE

An excessive accumulation of floating material causes a reduction in the volume available for separation. This risk worsens in the presence of considerable quantities of sedimentable substances that settle at the bottom of the plant. To prevent the escape of solids and mineral oils that could compromise the quality of the discharged effluent, it is advisable to carry out inspections and removal of the accumulated pollutants. These operations should be more frequent if the plant receives effluent from vehicle workshops, oil storage areas or service stations.

As far as maintenance of the coalescing filter oil separators is concerned, in addition to the normal emptying by specialist technicians, it is also advisable to remove the sponge support and wash it thoroughly upstream of the plant.

MANAGEMENT

WHAT TO DO	WHEN	HOW
Inspect the coalescing filter type oil separator	Every 1 / 2 months	Unscrew the covers on the inspection holes and check the level of sediment and the floating material
Clean the coalescing filter	Every 1/2 months	Extract the steel cage containing the filter and wash it with a jet of water at the head of the plant
Remove the floating material, the bottom sludge and clean the inlet and outlet pipes	Every 6 / 12 months	Contact a licensed waste disposal company

N.B. how often operations are carried out will depend on the incoming pollutant load and the frequency of rainfall.

PROHIBITIONS

- do not use toxic and/or poisonous substances (bleach, solvents, insecticides, disinfectant substances, aggressive detergents).

WARNINGS

- make sure that drains have a siphon;
- check that the pipes slope sufficiently (approximately 1% - 2%);
- connect the biogas vent pipe (see installation method);
- after emptying, fill the tank again with clean water;
- in the event of a maintenance operation of any kind, always comply with the safety regulations regarding operations within closed waste water treatment areas, and with the general technical procedures applicable
- products in PE manufactured using rotational moulding can have the following tolerances: +/- 3% on dimensions and +/- 5% on capacity

HORIZONTAL GRIT AND OIL SEPARATOR

TECHNICAL CHARACTERISTICS

The plant allows the continuous treatment of stormwater run-off from impermeable surfaces up to 27000 m² used for transit or parking in industrial areas, residential zones and service stations subject to possible pollution from mineral oils, hydrocarbons, sand/grit and inert materials. The stormwater run-off treatment system makes use of the action of a grit and oil separator in continuous operation capable of treating flows of up to 150 l/s.

Run-off from impermeable transit areas must be carried to the treatment system. For flow rates higher than the design data, the by-pass is activated, sending the excess flow to the rainwater system.

The treatment plant consists of a grit separator and a coalescing filter type oil separator, thus ensuring that the final effluent possesses the appropriate characteristics for discharge to a body of surface water.

The coalescing filter oil separators are certified under Standard UNI-EN 858-1 and bear the CE mark.

The plant is effective for the following parameters:

- Sedimentable solids.
- Total hydrocarbons and other light liquids that have not been emulsified of specific weight up to 0.85 g/cm³.

USE AND MAINTENANCE

The pollutants separated from the stormwater run-off inside the plant are mainly non-biodegradable (grit, lime, stone, hydrocarbons, oils, etc.). These tend to build up inside the various tanks. Over time, this build-up becomes excessive and tends to have a negative effect on the efficiency of the treatment plant (blocked pipes, release of the pollutants themselves, etc.).

It is therefore necessary to carry out periodic inspection of the tanks and, if necessary, to pump them out and clean them, contacting licensed waste disposal companies.

The inspections must be more frequent during the first months the system is in operation, in order to identify approximately how often pump-out will be necessary.

MANAGEMENT

WHAT TO DO	WHEN	HOW
Inspect the grit separator	Every 1 / 2 months	Unscrew the covers on the inspection holes and check the level of sediment and the floating material
Inspect the coalescing filter type oil separator	Every 1 / 2 months	Unscrew the covers on the inspection holes and check the level of sediment and the floating material
Clean the coalescing filter	Every 1 / 2 months	Extract the steel cage containing the filter and wash it with a jet of water at the head of the plant
Remove the floating material, the bottom sludge and clean the inlet and outlet pipes	Every 6 / 12 months	Contact a licensed waste disposal company who will empty all the elements in the plant

N.B. how often operations are carried out will depend on the incoming pollutant load and the frequency of rainfall.

WARNINGS

- make sure that drains have a siphon;
- check that the pipes slope sufficiently (approximately 1% - 2%);
- connect the biogas vent pipe (see installation method);
- after emptying, fill the tank again with clean water;
- inspect the tanks periodically both during and after rain, so as to check that the various devices and elements are working properly;
- in the event of a maintenance operation of any kind, always comply with the safety regulations regarding operations within closed waste water treatment areas, and with the general technical procedures applicable.
- products in PE manufactured using rotational moulding can have the following tolerances: +/- 3% on dimensions and +/- 5% on capacity



SEWAGE



WATER



UNDERGROUND INSTALLATION



LIFT STATIONS

TECHNICAL CHARACTERISTICS

Sewage lift stations are systems that allow effluent to be lifted and transferred to stations located at higher levels (sewerage systems, treatment systems). They become necessary, for example, when the discharge level of a WC is lower than that of the treatment plant or sewerage pipes (cellars, underground premises, etc.) and when the hydraulic profile of the treatment system cannot work by gravity.

The station consists of a high density linear polyethylene (LHDPE) storage tank of various sizes, with a submerged electric pump installed inside it. The pump is connected to the tank by a chain to facilitate its removal, and the inlet pipe is fitted with a cast iron ball backflow valve.

Dual pump models are provided if the flow rates of waste water to be lifted are very high and/or variable and if the presence of a spare pump is necessary. The pumps are connected to suitable electric panels so that, according to requirements, the start-up command can be either manual or automatic by means of start/stop float switches located inside the tank.

The dual pump models are provided with an electric panel allowing alternating or simultaneous operation of the 2 pumps to be activated. The electric panel can also be fitted with visual alarms (warning lights) and is set-up for connecting an audible alarm device. The power supply can be single-phase (domestic type: 230 V) or three-phase (industrial type: 400 V).

Depending on need, the lift stations can be equipped with various types of pumps with different heads, flow rates and working pressures. For pumps with special characteristics, contact the ROTOTEC technical office. Three-phase electric pumps and electric panels available on request.

N.B. TEKNOSOL lift stations are delivered on pallets with pumps boxed separately and therefore not installed.

USE AND MAINTENANCE

All maintenance operations must be carried out with the pump disconnected from the power supply. The pump must be disconnected by trained technicians, so that there is no risk of it starting accidentally.

The maintenance recommendations indicated are not to be understood as "do-it-yourself" operations, as they require specific technical knowledge. A service contract with a specialist technician will ensure you receive the best technical assistance at all times. In order for a lift station to function efficiently, it is important that the most suitable pump for satisfying the specific requirements is selected during the design phase. To this end, a few important parameters such as the origin and characteristics of the effluent to treat, the function of the lift station, the head and linear distance to the receiver must be evaluated. Even when the pump is capable of handling solid matter (vortex impeller) it is nevertheless advisable to install a primary sedimentation system (e.g. septic tank) upstream or a sewage screening system that can separate non-shreddable materials such as rags, plastics, etc. The installation of such a system is essential when pumps with 2-channel impellers are installed.

Under normal operating conditions, the electric pumps do not require any maintenance operations.

MANAGEMENT

WHAT TO DO	WHEN	HOW
Inspect the lifting station	Every 6 months	Unscrew the covers on the inspection holes and check the level of sediments on the bottom
Check the seal on pipes, connectors and gaskets	Every 6 months	Check inlet and outlet pipes
Check vent pipe	Every 6 months	If anything is obstructing the free flow of air, remove it
Check the pumping system	Every 12 months	Extract the pump*, clean the inlet to remove any debris, assess the state of the impeller, the electric cable and the floats
Remove bottom sediment and clean the inlet and outlet pipes	Every 6 / 12 months	Contact a licensed waste disposal company

* To dismantle a pump it is necessary to unfasten the compression fitting on the pump delivery pipe, then extract the pump, with the aid of the lifting cord.

- products in PE manufactured using rotational moulding can have the following tolerances:
+/- 3% on dimensions and +/- 5% on capacity

WARNINGS

- provide for a vent of a size suited to the power of the pump, to prevent the formation of a vacuum in the tank;
- only start the electric pump once it has been installed; do not attempt a dry start;
- do not remove the suction filter, if there is one, for any reason whatsoever;
- avoid operating the pump in the horizontal position. The electric pump can only function in the vertical position (with the motor at the top and the pump part at the bottom);
- on the three-phase version, the correct direction of rotation is indicated by the arrow stamped on the pump body and on the identification plate;
- if the electric pump is not properly fixed, it may become unsteady or topple over on start-up due to the starting torque;
- never use the electric pump to pump dangerous liquids (toxic, flammable, etc...);
- in the event of a maintenance operation of any kind, always comply with the safety regulations regarding operations within closed waste water treatment areas, and with the general technical procedures applicable.
- provide for a vent of a size suited to the power of the pump, to prevent the formation of a vacuum in the tank;
- only start the electric pump once it has been installed; do not attempt a dry start;
- do not remove the suction filter, if there is one, for any reason whatsoever;
- avoid operating the electric pump in the horizontal position. The pump can only function in the vertical position (with the motor at the top and the pump section at the bottom)

RISK OF ELECTRIC SHOCK:

- do not transport or handle the pump using the electric power supply cable;
- never move the electric pump when it is operating or with the power cable connected to the power supply;
- before connecting up the electric pump, make sure that the power supply network is properly earthed;
- before carrying out any type of control or maintenance operation, disconnect the power supply;
- never start the pump if you are in contact with the liquid to be pumped;
- always ensure that the electric pump is checked and repaired by authorised personnel only. Unauthorised repairs might make the product unsafe and/or dangerous;
- never put your hands or other objects into the pumped liquid inlets or outlets in the vicinity of the impeller, if present, as this is a moving part;



SEWAGE







WATER

UNDERGROUND
INSTALLATION

TROUBLESHOOTING



TREATMENT PLANTS

 PROBLEM	 CAUSE	 CHECK	 SOLUTION
The grease separator gives off an unpleasant smell	Biogas vent not connected or blocked	Check the state of the biogas pipe	Connect the biogas vent Ensure the biogas pipe is free
	The grease separator must be cleaned	Check the level of sediment	Contact a licensed waste disposal company
The septic tank gives off an unpleasant smell	Biogas vent not connected or blocked	Check the state of the biogas pipe	Connect the biogas vent Ensure the biogas pipe is free
	The tank has not yet activated	Days of use	Addition of bioactivators
		Check the actual number of users	
The tank must be cleaned	Check the level of sludge in the tank	Contact a licensed waste disposal company	
The activated sludge system gives of an unpleasant smell	Check the blower	Timed blower	The blower must always be on
		The blower has stopped working	Contact the Technical Department
	The plant must be cleaned	Check the level of sludge in the plant	Contact a licensed waste disposal company
The aerated trickle filter gives off an unpleasant smell	Biogas vent not connected or blocked	Check the state of the biogas pipe	Connect the biogas vent Ensure the biogas pipe is free
	The filter has not yet activated	Bulk fill material not covered by a film of bacteria	Addition of bioactivators
		Check the actual number of users	
The filter must be emptied	Check the level of sludge in the filter	Contact a licensed waste disposal company	
There is a bad smell in the house	Non-trapped drains	Check domestic drains	Trap the inlet pipes to the system

N.B. For any other problems, please contact the Rototec Technical Department immediately.

TROUBLESHOOTING

LIFT STATIONS

 PROBLEM	 CAUSE	 SOLUTION	
The electric pump does not work, the motor does not turn	no power supply	check the power supply	
	circuit broken	check the circuit	
	pump blocked	check the state of the electric pump	
	float blocked	check that the float is free and that it reaches the ON level	
	impeller blocked	free the impeller from any obstructions	
	thermal cut-out triggered	- the pump will re-start automatically - check that the amp range corresponds with that of the pump - adjust the amp range of the thermal cut-out manually	
		short-circuit	use a tester to check the values of the pump connection wires
The motor turns, but the electric pump does not work or the flow rate is restricted	bad connections (three-phase model)	reverse the phase connections	
	delivery pipe or suction filter partially blocked	remove the obstructions	
	non return valve blocked	clean the valve	
	turns in the wrong direction	reverse the direction of rotation	
	project values have changed	check that the required head, linear distance or flow rate indicated in the offer have not changed	
	pipes are leaking	check that the pipes are undamaged	
When a dual pump is installed, the pumps never stop working	bad connections	check the float connections	

For further information on how to deal with malfunctions please see the information provided in the manual for installation and use of the electric panel supplied inside the panel itself.

N.B. For any other problems, please contact the Rototec Technical Department immediately.



SEWAGE



WATER



UNDERGROUND INSTALLATION





SEWAGE



WATER



UNDERGROUND INSTALLATION



SOIL ABSORPTION SYSTEM

TECHNICAL CONSTRUCTION REQUIREMENTS

The dispersion pipe must preferably consist of continuous tubular elements in HDPE of diameter 110-125 mm, with 5 to 10 mm wide slots formed in the lower part perpendicular to the pipe centreline and spaced 10 - 20 cm. The dispersion pipe must have a gradient of between 0.2% and 0.5%. The pipe is laid in a trench of minimum depth 60 cm and maximum depth 80 cm, with the width at the base not less than 40 cm. The bottom of the trench must be filled with a bed of washed stone of size 40/70 of minimum depth 30 cm. The dispersion pipe is laid at the centre of the stone bed. Prior to being covered with fill material, the top surface of the stone bed must be protected using a layer of material suitable for preventing the overlying soil from becoming clogged while at the same time guaranteeing that the drainage system remains aerated. A geotextile membrane is particularly suitable for this type of application.

On completion of the works, the summit of the trench must be slightly higher than the adjacent ground in order to prevent the formation of low spots and channels that would allow rainwater to penetrate into the drainage system. The dispersion pipe can be:

1. single;
2. branching;
3. laid along parallel lines.

In the last case, the pipes are laid at no less than 2 metres between centrelines. Greater distances, where possible, will improve the efficiency of the dispersion. On steeply sloping ground, the adoption of a soil absorption discharge system must be carefully evaluated with respect to possible landslide phenomena linked to the geomorphological and geotechnical characteristics of the ground in question. This solution however should not be adopted in cases where the sloping ground has a gradient of more than 15%, otherwise there is a risk of the

distributed effluent rising to the surface at the lower levels. The pipeline must, nevertheless, follow the direction of the contour lines in order to prevent the dispersion pipes from exceeding the above-mentioned ideal gradients.

For sanitary and operational reasons, trenches housing dispersion pipes must be located far from buildings and paved areas or must be arranged in a manner that prevents the passage of air in the ground. In this respect, the following minimum distances should be respected: In the presence of groundwater, the distance between the bottom of the dispersion trench and the maximum level of the groundwater must not be less than 1 m. For this purpose, the maximum level of the groundwater is intended as being the level reached by the water table, with respect to ground level, under maximum flow conditions. The length of the dispersion pipe per user depends on the type of ground available. For reference purposes, the table shown alongside has been taken.

Structure types	Safety distance
Buildings	defined by local regulations
Wells, pipes, tanks or any other private works used for the supply of drinking water	30 m
Wells, pipes, tanks or any other public works used for the supply of potable water	200 m

Soil composition	Length of dispersion pipe
Fine sand or light fill material	2 m/P.E.
Coarse sand and crushed stone	3 m/P.E.
Fine sand with clay	5 m/P.E.
Clay with some sand content	10 m/P.E.
Compact clay	Unsuitable

The following diagrams show the possible layouts of dispersion pipes indicated in the guidelines for treating domestic sewage and similar in areas not served by public sewers.

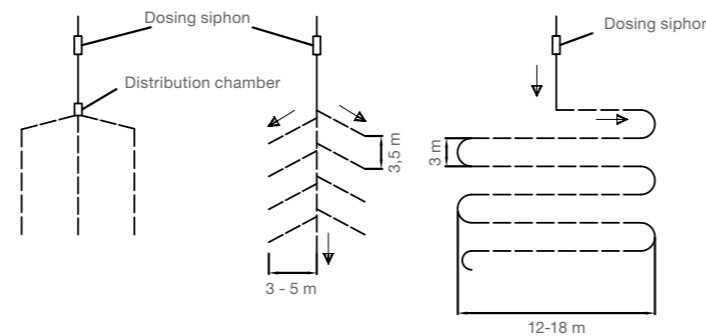

SOIL ABSORPTION SYSTEM

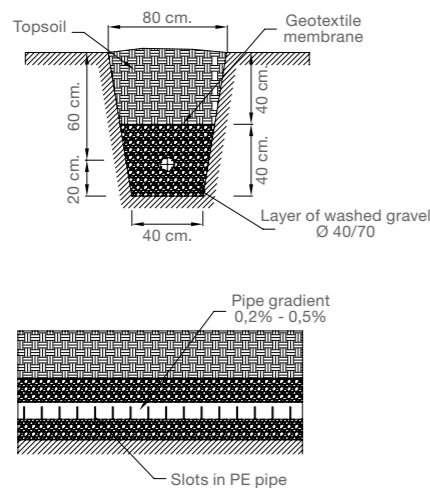

Another effluent treatment system with construction characteristics similar to those of sub-irrigation and for treatment aspects to the above mentioned bacterial filters is drained sub-irrigation.

This treatment system consists of a trench of approximate depth 1.20 m and width of 80 cm at the upper part and 60 cm at the bottom. The discharge pipe (dispersion pipe), consisting of an HDPE pipe with cuts in the upper part, normally formed along the length of the pipe itself 7/10 cm apart, is laid on the bottom of the trench.

The whole trench is then filled to a height of 65 cm with washed coarse gravel of size 40/70. It is recommended that the size of the gravel be varied, placing a layer approximately 30 cm thick of 20/40 gravel at the bottom and one of 40/70 at the top. The upper pipe (drainage pipe) is positioned on top of this layer of gravel, and is connected to the Imhoff septic tank. This upper drainage pipe must have the same characteristics as the lower pipe, the only difference being that the cuts must be on the underside of the pipe. More coarse gravel must then be added to cover this pipe for a depth of approximately 15 cm. A layer of geotextile membrane is then placed over the gravel in order to prevent soil from filling the voids between the stones. The trench is then topped with approximately 30 cm of topsoil and the relative area reinstated.

The gradients of the pipes are an important factor and must never exceed 0.5%. The dispersion pipe must be at least 5 m longer than the drainage pipe. The upper (drainage) pipe must therefore be plugged at least 5 m before the discharge into the receptor.

In order to introduce an aerobic atmosphere into the filter media, aeration pipes must be laid in the trench at a distance of approximately 3 m. These aeration systems must be in 110-125 mm diameter HDPE pipes, perforated to allow the passage

DRAINED SOIL ABSORPTION SYSTEM

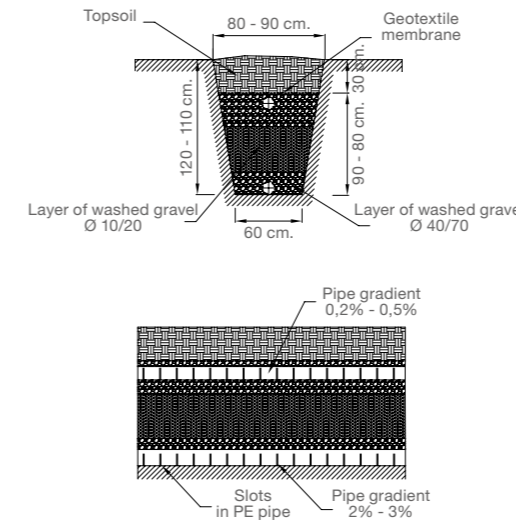

of air. The pipes must be connected to chambers with covers that prevent the entry of rainwater. In order to ensure the specific characteristics of this type of effluent treatment system, the trench must act as a natural container, as a result of which the ground where it is installed must be able to guarantee total geological impermeability. As far as the sizing of the drained soil absorption system is concerned, in order to guarantee a volume of filter media equal to 1-2 m³ per population equivalent, a minimum length of between 2 and 4 metres must be calculated per population equivalent. A suitable dosing siphon chamber must be installed between the Imhoff tank and the start of the soil absorption system in order to ensure that the effluent flows along the entire length of the drainage pipe.

PE DRAINAGE PIPES



Material

Corrugated PE pipe with slotted double wall, coated with geotextile filter fibre.

Applications

Drainage pipe for subterranean dispersion by sub-irrigation of the waste water leaving a treatment plant.

Installation

Follow the indications provided in this paragraph carefully.

Item	External Ø mm	Internal Ø mm	Pack
TUBODREN110	110	92	50 m roll
TUBODREN125	125	105	50 m roll
TUBODREN160	160	137	50 m roll

CALCULATING THE POPULATION EQUIVALENT ACCORDING TO THE TYPE OF USERS SERVED

The concept of Population Equivalent (P.E.) is useful for expressing the load on a treatment plant from a particular user in standard terms comparable with domestic users. The equivalence can refer to the hydraulic load, to the load in suspended solids or, more commonly, to the organic load expressed as BOD5. Population Equivalent is a conventional concept based on the mean contribution from a typical user equal to 60 g/BOD5 per inhabitant. It is also particularly useful in that it allows a simple comparison to be made between the loads from very different users, expressing each user as a "population equivalent" load. The following tables indicate the operations necessary for calculating the P.E.'s of users that can be assimilated to a residential building.

Residential building

$$\text{Residents} \times \frac{1}{\text{Coefficient}} = \text{Population equivalent}$$

Offices

$$\text{Employees} \times \frac{0.3}{\text{Coefficient}} = \text{Population equivalent}$$

Restaurants

$$\text{Place settings} \times \frac{0.3}{\text{Coefficient}} = \text{Population equivalent}$$

Cafés and bars

$$\text{Customers} \times \frac{0.07}{\text{Coefficient}} = \text{Population equivalent}$$

Camp sites and holiday villages

$$\text{Guests and personnel} \times \frac{0.8}{\text{Coefficient}} = \text{Population equivalent}$$

Cinemas and theatres

$$\text{Seats} \times \frac{0.13}{\text{Coefficient}} = \text{Population equivalent}$$

Charitable institutes and retirement homes

$$\text{Beds} \times \frac{2}{\text{Coefficient}} = \text{Population equivalent}$$

Residential building

(based on the surface areas of the bedrooms)

$$\begin{aligned} & 1 \text{ P.E. for bedrooms with a surface area of up to } 14 \text{ m}^2 \\ & 2 \text{ P.E. for bedrooms with surface area of over } 14 \text{ m}^2 \end{aligned}$$

Dance halls

$$\text{Customers} \times \frac{0.2}{\text{Coefficient}} = \text{Population equivalent}$$

Hospitals

$$\text{Beds} \times \frac{2}{\text{Coefficient}} = \text{Population equivalent}$$

Motorway restaurants

$$\text{Seating per hour} \times \frac{2}{\text{Coefficient}} = \text{Population equivalent}$$

Hotels, guest houses, holiday farms, boarding houses

$$\text{Guests and personnel} \times \frac{1}{\text{Coefficient}} = \text{Population equivalent}$$

Schools and educational institutes

$$\text{Students and personnel} \times \frac{0.26}{\text{Coefficient}} = \text{Population equivalent}$$

CERTIFICATES



SEWAGE



WATER



UNDERGROUND INSTALLATION



WATER TANKS



SEWAGE



WATER



UNDERGROUND INSTALLATION



TECHNICAL SECTION

CHAMBERS

LIFT STATIONS

CAR WASH PLANTS

STORMWATER MANAGEMENT

DEPURO

DEPURBLOK

SECONDARY TREATMENT PLANT

TRICKLE FILTERS

ACTIVATED SLUDGE PLANT

BIOLOGICAL SEPTIC TANKS

IMHOFF BIOLOGICAL TANKS

GREASE SEPARATORS

TECHNICAL SECTION

CHAMBERS

RAINWATER HARVESTING AND RE-USE SYSTEMS

UNDERGROUND TANKS

CONSTRUCTION SITE EQUIPMENT

ACCESSORIES

ABOVE-GROUND TANKS

ABOVE-GROUND TANKS

UNDERGROUND INSTALLATION

NON-STANDARD SOLUTIONS

PORTABLE TOILETS

OIL DISPOSAL UNIT

CONSTRUCTION SITE EQUIPMENT

ACCESSORIES

ABOVE-GROUND TANKS

UNDERGROUND INSTALLATION

NON-STANDARD SOLUTIONS



WATER DIVISION

p. 184	ABOVE-GROUND TANKS
p. 200	MODULAR FIREFIGHTING TANKS
p. 204	UNDERGROUND TANKS
p. 238	RAINWATER HARVESTING AND RE-USE
p. 260	CHAMBERS
p. 265	TECHNICAL SECTION

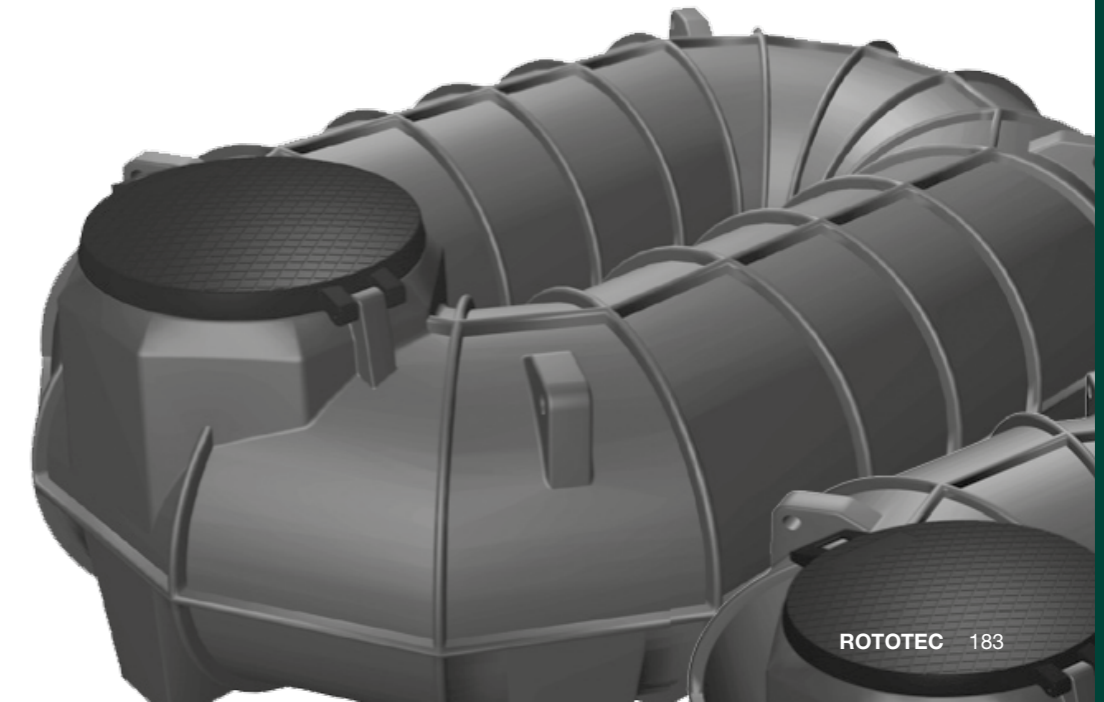



SEWAGE



WATER



UNDERGROUND INSTALLATION



ABOVE-GROUND TANKS



SPECIFICATIONS

Monolithic above ground tanks manufactured by rotational moulding technology, in linear polyethylene (LLDPE), fitted with threaded inspection cover in PP with vent and hinged inspection cover in PE (only for mod. C5000, V10000, P11000, P15000), provided with co-moulded female threaded openings for inlet, outlet and full drain (according to model).

Thanks to rotational moulding technology and the chemical-physical-mechanical characteristics of linear polyethylene (LLDPE), the above-ground tanks hold the ideal characteristics for accumulating large volumes of liquids of large volumes of liquids. Polyethylene, in fact, is totally **non-toxic and does not foster the growth of algae in the fluids contained in the tanks, thus making the tanks ideal for storing potable water and other foodstuffs.** Furthermore, linear polyethylene also supports sudden changes in temperature (from -20°C to +80°C) and is inert in the presence of chemical and physical atmospheric agents. For these reasons, there are no material oxidation or corrosion problems that would prejudice the mechanical characteristics and impermeability of the tanks. These characteristics are also guaranteed by the fact that rotational moulding allows the production of **one-piece** tanks, i.e. free from welds that could weaken parts that are subjected to internal stresses. Furthermore, while they guarantee the same characteristics as other materials (cement, fibreglass, metal), polyethylene tanks are much lighter, so that transport, installation and maintenance operations are extremely **simple and economical**.

Reference standards

Regulation (CE) No. 1935/2004,
Regulation (EU) No. 10/2011,
Commission regulation (EU) 2020/1245.

The tank is suitable to contain foodstuffs according to the limits indicated in the Certificate of Conformity issued by CSI SpA - Senago - Milan.



VERTICALE

FIND OUT MORE



Type
Above-ground tank

Applications
Storage of drinking and rain water, containment of foodstuffs (water, oil, wine)

Volumes
From 50 to 10000 litres

Installation
Placed directly on a flat supporting surface

Available colours

standard ● blue on request ● grey ● green ● terracotta



Item	Capacity l	Ø cm	Height cm	Cover Ø cm	Cover	Inlet	Outlet	Full drain	Lifting eye	Threaded insert distance cm		
										A	B	Centre distance
V50	50	43	43	30	CS300	N.P.	N.P.	¾"	-	4.5	-	-
VN150	150	60	70	21	CS200	¾"	N.P.	¾"	-	4	-	-
VN300	300	63	110	21	CS200	¾"	N.P.	¾"	-	4	-	-
VN500	500	68	152	30	CS300	¾"	1"	¾"	-	9	4	6
VN1000	1000	85	193	30	CS300	¾"	1"	¾"	3	9	4	8
VN2000	2000	115	210	40	CS400	1"	1"	¾"	3	10	5	9
VN3000	3000	135	230	40	CS400	1"	1½"	1"	3	11	6	10
VN5000	5050	180	223	40	CS400	1"	1½"	1"	3	11	6	10
V10000	10000	240	270	63	TAP700	N.P.	N.P.	N.P.	4	-	-	-

N.P. Not present.

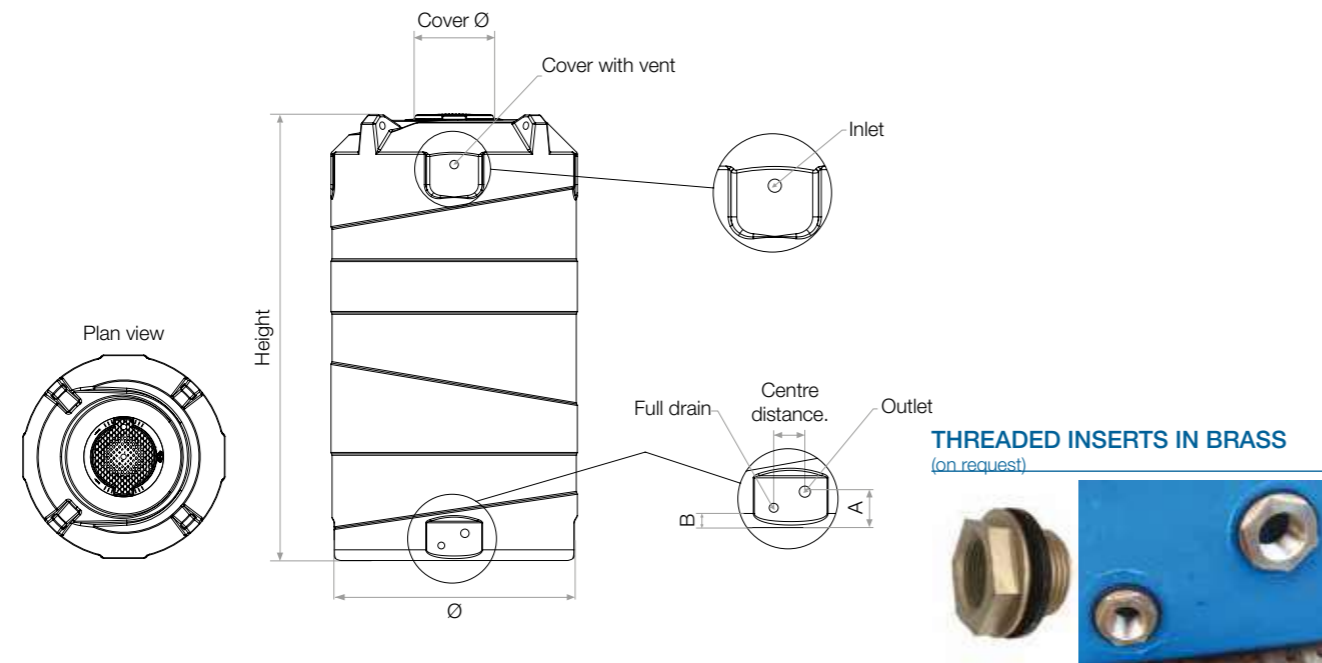

See table on page 199

PANETTONE

FIND OUT MORE



Type
Above-ground tank

Applications
Storage of drinking and rain water, containment of foodstuffs (water, oil, wine)

Volumes
From 500 to 14300 litres

Installation
Placed directly on a flat supporting surface which is also suitable for transport

Available colours

standard ● blue on request ● grey ● green ● terracotta



Item	Capacity l	Ø cm	Height cm	Cover Ø cm	Cover	Inlet	Outlet	Full drain	Lifting eye	Threaded insert distance cm		
										A	B	Centre distance
PN500	538	100	80	21	CS200	¾"	¾"	N.P.	-	5	-	-
PN1000	1040	120	105	30	CS300	1"	1"	¾"	3	9	5	11
PN2000	2075	150	133	40	CS400	1"	1"	¾"	3	9	5	11
PN3000	3105	183	135	40	CS400	1"	1"	¾"	3	10	6	12
PN5000	4905	225	135	40	CS400	1"	1½"	1"	3	10	6	12
PN7500	7800	225	210	40	CS400	1"	1½"	1"	3	10	6	12
P11000	11150	240	278	63	TAP700	N.P.	N.P.	N.P.	3	-	-	-
P15000	14300	240	355	63	TAP700	N.P.	N.P.	N.P.	3	-	-	-
P20000	20075	240	510	63	TAP700	N.P.	N.P.	N.P.	3	-	-	-

N.P. Not present.

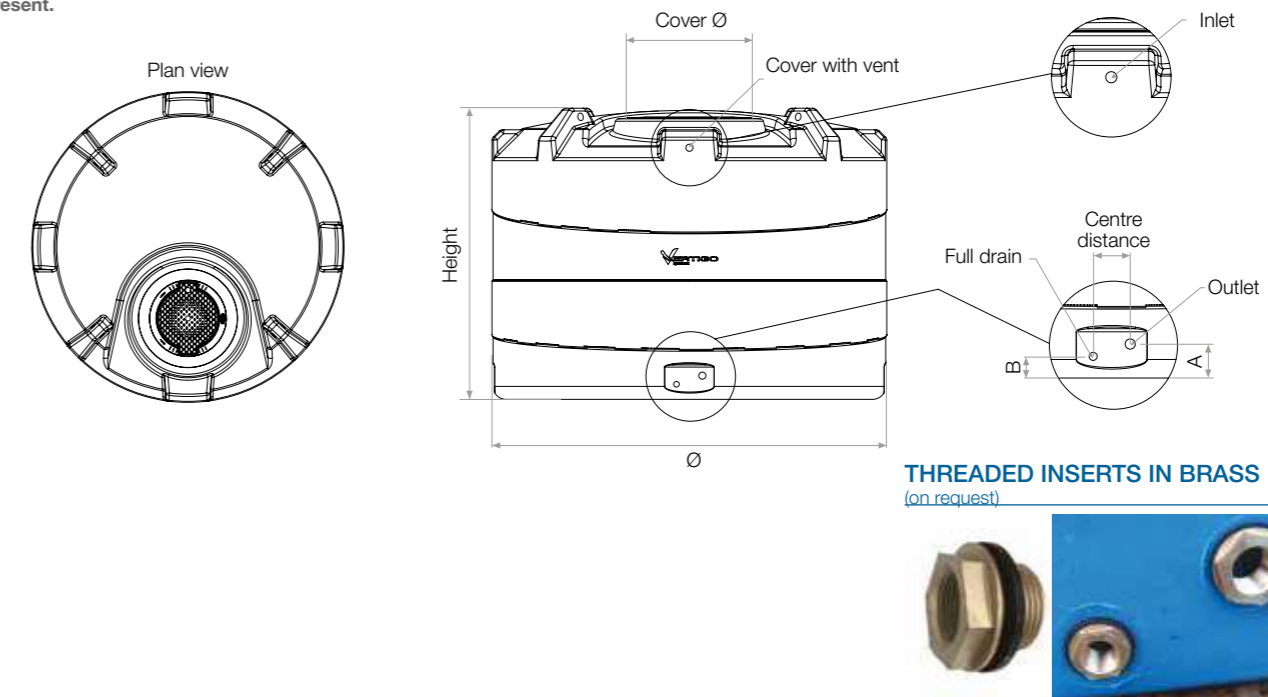

See table on page 199

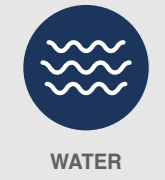

CISTERNA

[FIND OUT MORE](#)



Type
Above-ground tank

Applications
Storage of drinking and rain water, containment of foodstuffs (water, oil, wine)

Volumes
From 300 to 5000 litres

Installation
Placed directly on a flat supporting surface

Available colours

standard ● blue | on request ● grey ● green ● terracotta 

Item	Capacity l	Length cm	Width cm	Height cm	Cover Ø cm	Cover	Inlet	Outlet	Full drain	Lifting eye	Threaded insert distance cm		
											A	B	Centre distance
C300	300	113	63	66	21	CS200	¾"	1"	¾"	-	4	4.2	8.5
C500	565	120	80	83	21	CS200	¾"	N.P.	¾"	-	-	4	-
C1000	1020	155	97	104	30	CS300	1"	1"	¾"	-	7	4	11
C1500	1665	170	115	122	40	CS400	1"	1"	¾"	2	7	4	11
C2000	2200	190	125	132	40	CS400	1"	1"	¾"	2	7	4	12
C3000	3260	210	145	152	40	CS400	1"	1"	¾"	2	7	4	12
C5000	5000	220	173	192	63	TAP700	N.P.	N.P.	N.P.	2	-	-	-

N.P. Not present

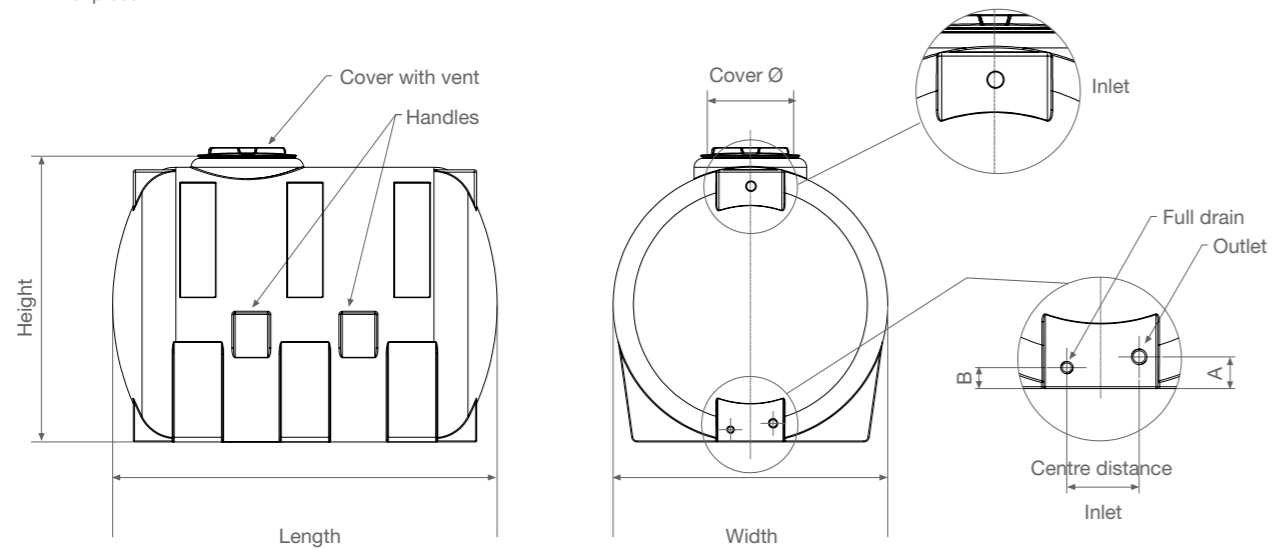

THREADED INSERTS IN BRASS
(on request)



See table on page 199

JOLLY

[FIND OUT MORE](#)



Type
Above-ground tank

Applications
Storage of drinking and rain water, containment of foodstuffs (water, oil, wine)

Volumes
From 1000 to 3000 litres

Installation
Easy to position and handle, designed for narrow passages, cellars, basements, placed directly on a flat supporting surface

Available colours

standard ● blue | on request ● grey ● green ● terracotta 

Item	Capacity l	Length cm	Width cm	Height cm	Cover Ø cm	Cover	Inlet	Outlet	Full drain	Lifting eye	Threaded insert distance cm		
											A	B	Centre distance
J1000	1000	150	68	145	30	CS300	1"	1"	¾"	-	6	6	8
J2000	2000	233	68	190	30	CS300	1"	1"	¾"	-	6	6	8
J3000	3000	260	80	200	40	CS400	1"	1"	¾"	-	7	5	10

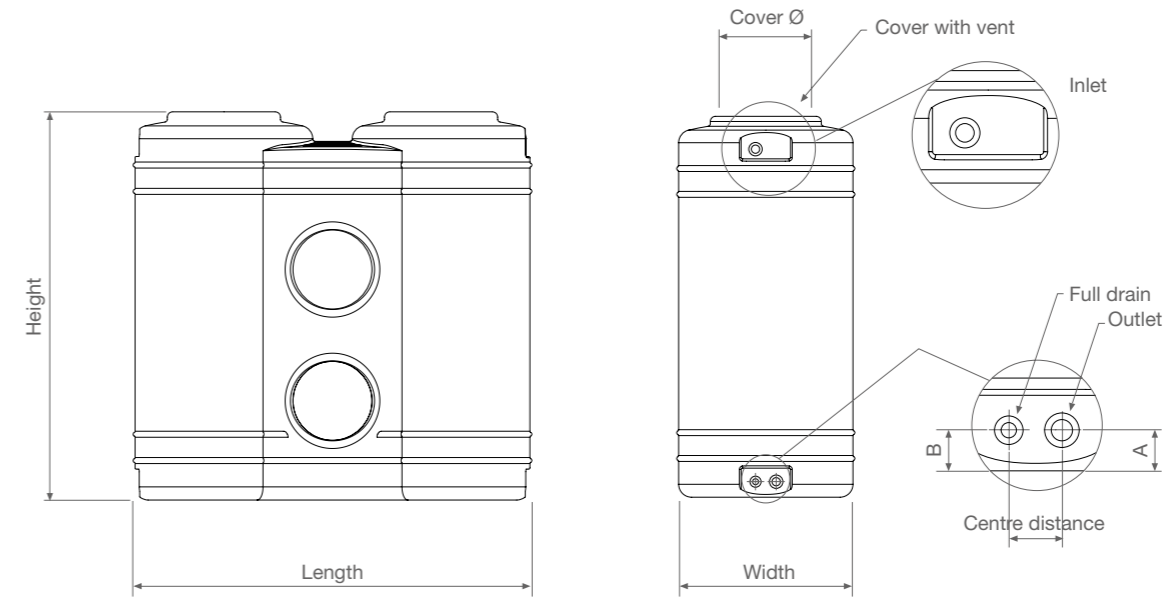

THREADED INSERTS IN BRASS
(on request)



See table on page 199



VALIGIA

[FIND OUT MORE](#)

BOX

[FIND OUT MORE](#)



Type
Above-ground tank

Applications
Storage of drinking and rain water, containment of foodstuffs (water, oil, wine)

Volumes
From 500 to 1000 litres

Installation
Placed directly on a flat supporting surface

Available colours

standard: blue | on request: grey, green, terracotta

Item	Capacity l	Length cm	Width cm	Height cm	Cover Ø cm	Cover	Inlet	Outlet	Full drain	Lifting eye	Threaded insert distance cm		
											A	B	Centre distance
RV500	500	99	65	105	21	CS200	N.P.	1"	¾"	-	6.6	4.6	10
RV1000	1000	139	80	115	30	CS300	N.P.	1"	¾"	-	6.8	4.8	10.5

N.P. Not present.

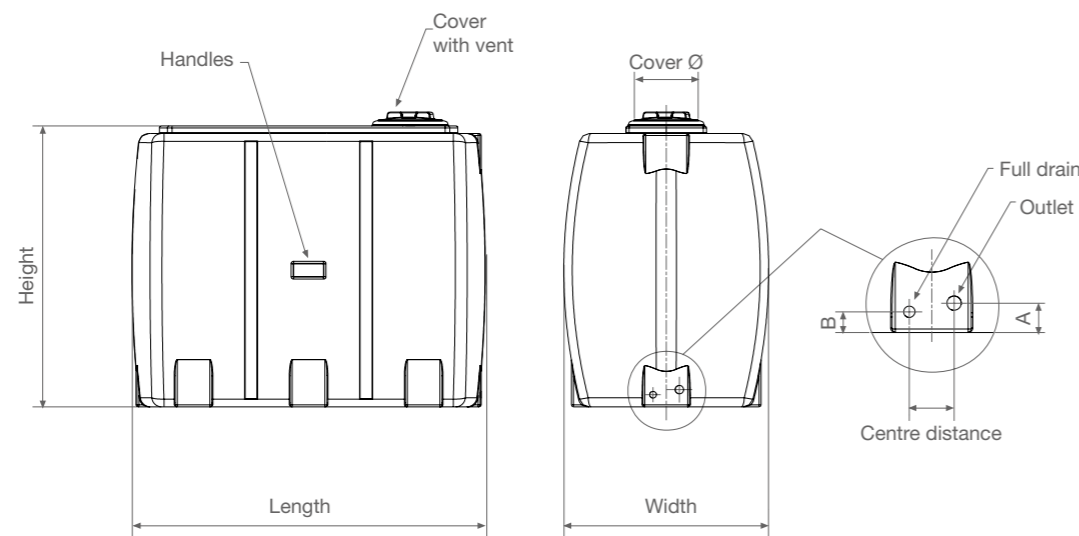

THREADED INSERTS IN BRASS
(on request)



See table on page 199



Type
Above-ground tank

Applications
Storage of drinking and rain water, containment of foodstuffs (water, oil, wine)

Volumes
From 300 to 500 litres

Installation
Placed directly on a flat supporting surface which is also suitable for transport

Available colours

standard: blue | on request: grey, green, terracotta

Item	Capacity l	Length cm	Width cm	Height cm	Cover Ø cm	Cover	Inlet	Outlet	Full drain	Lifting eye	Threaded insert distance cm		
											A	B	Centre distance
B300	290	80	55	80	21	CS200	N.P.	1"	¾"	-	3.8	3.8	10
B500	500	80	55	130	21	CS200	N.P.	1"	¾"	-	3.8	3.8	10

N.P. Not present.

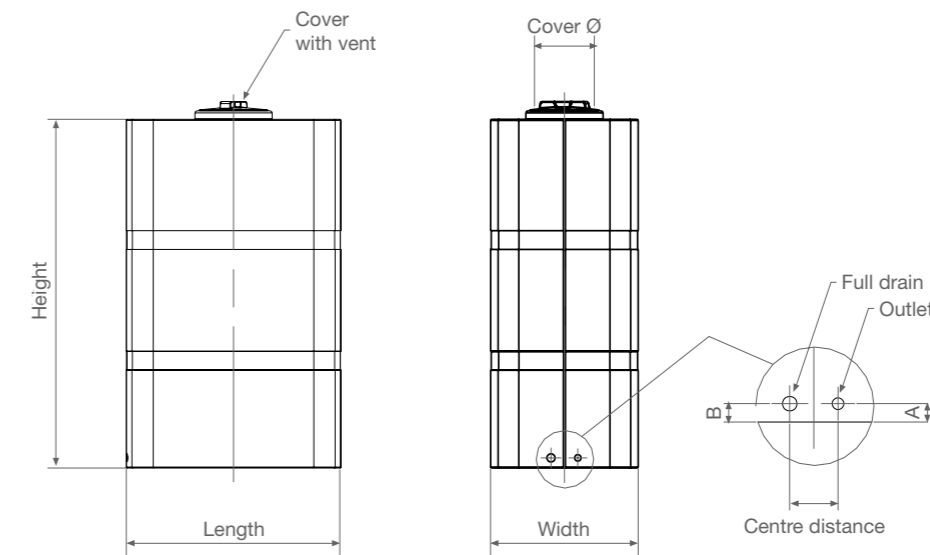

THREADED INSERTS IN BRASS
(on request)



See table on page 199

SNELLO

[FIND OUT MORE](#)



Type
Above-ground tank

Applications
Storage of drinking and rain water, containment of foodstuffs (water, oil, wine)

Volumes
From 300 to 800 litres

Installation
Placed directly on a flat supporting surface, ideal for confined spaces

Available colours

standard | on request

● blue | ● grey ● green ● terracotta



Item	Capacity l	Length cm	Width cm	Height cm	Cover Ø cm	Cover	Inlet	Outlet	Full drain	Lifting eye	Threaded insert distance cm		
											A	B	Centre distance
S300	300	98	46	105	21	CS200	N.P.	¾"	N.P.	-	3.8	-	-
S800	750	122	67	130	30	CS300	N.P.	1"	N.P.	-	5.6	-	-

N.P. Not present

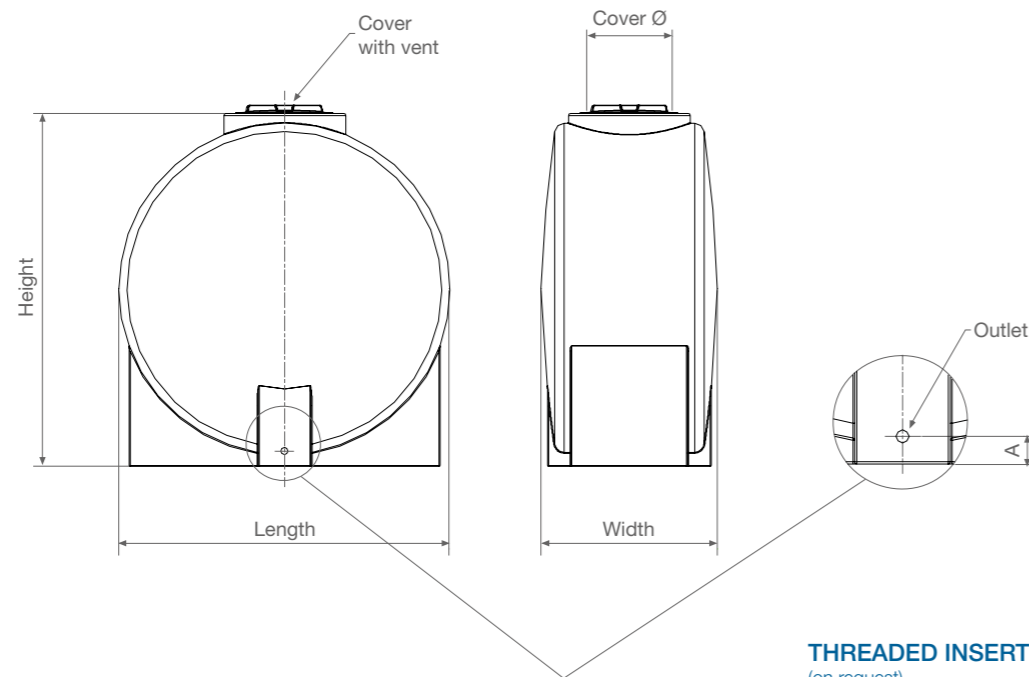

THREADED INSERTS IN BRASS
(on request)



See table on page 199

SOTTOTETTO

[FIND OUT MORE](#)



Type
Above-ground tank

Applications
Storage of drinking and rain water, containment of foodstuffs (water, oil, wine)

Volumes
300 litres

Installation
Placed directly on a flat supporting surface, ideal for confined spaces

Available colours

standard | on request

● blue | ● grey ● green ● terracotta



Item	Capacity l	Length cm	Width cm	Height cm	Cover Ø cm	Cover	Inlet	Outlet	Full drain	Lifting eye	Threaded insert distance cm		
											A	B	Centre distance
ST300	300	160	50	42	21	CS200	N.P.	1"	¾"	-	5.2	3.6	7

N.P. Not present

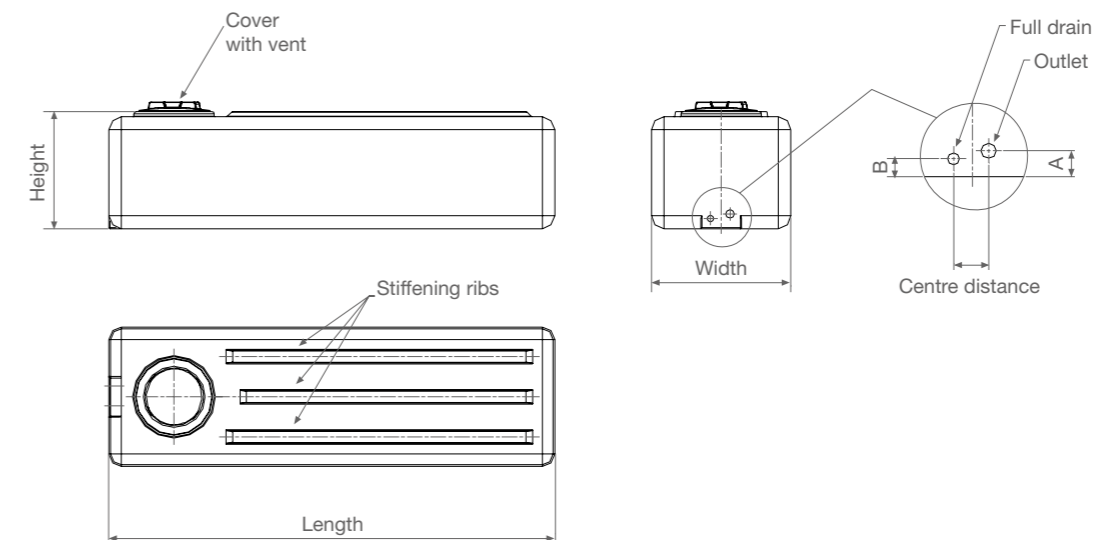

THREADED INSERTS IN BRASS
(on request)



See table on page 199

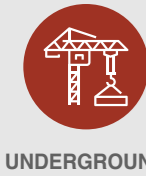
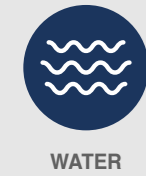
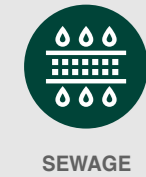

SOTTOSCALA

FIND OUT MORE

CUBO

FIND OUT MORE



Type
Above-ground tank

Applications
Storage of drinking and rain water, containment of foodstuffs (water, oil, wine)

Volumes
500 litres

Installation
Placed directly on a flat supporting surface

Available colours

standard | on request

● blue | ● grey ● green ● terracotta



Item	Capacity l	Length cm	Width cm	Height cm	Cover Ø cm	Cover	Inlet	Outlet	Full drain	Lifting eye	Threaded insert distance cm		
											A	B	Centre distance
SS500	500	133	76	80	21	CS200	N.P.	1"	¾"	-	5.2	3.6	7

N.P. Not present.

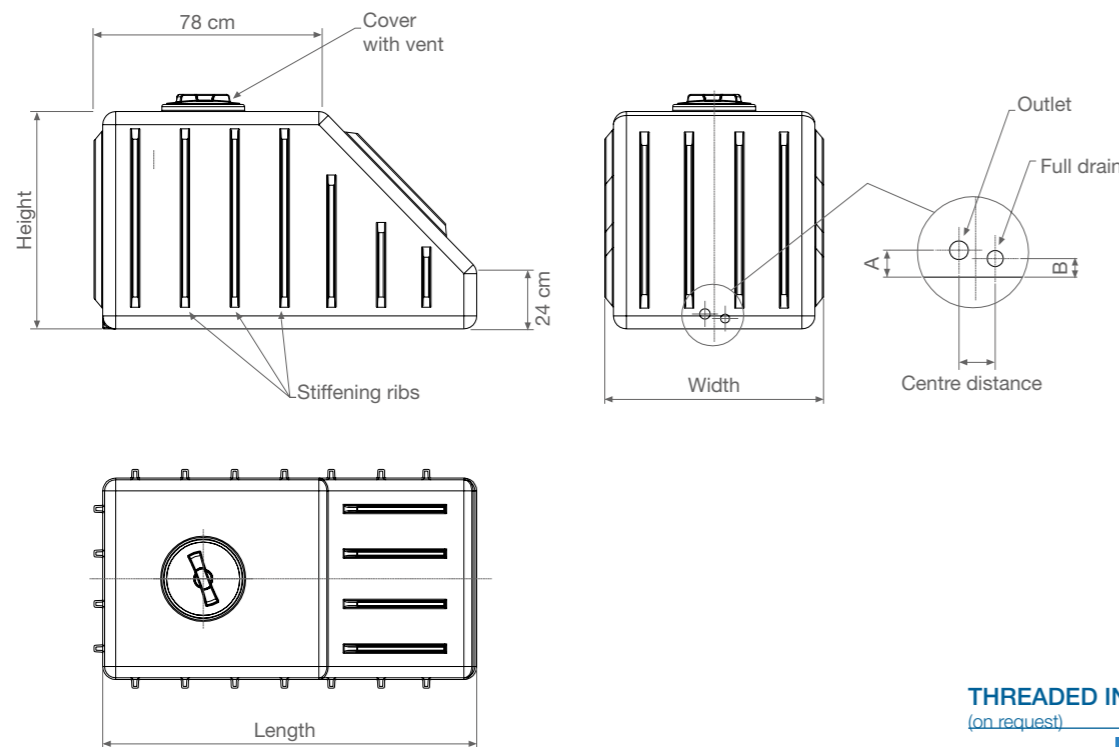

THREADED INSERTS IN BRASS
(on request)



See table on page 199



Type
Above-ground tank

Applications
Storage of drinking and rain water, containment of foodstuffs (water, oil, wine)

Volumes
From 220 to 500 litres

Installation
Placed directly on a flat supporting surface

Available colours

standard | on request

● blue | ● grey ● green ● terracotta



Item	Capacity l	Length cm	Width cm	Height cm	Cover Ø cm	Cover	Inlet	Outlet	Full drain	Lifting eye	Threaded insert distance cm		
											A	B	Centre distance
Q200	230	71	71	51	30	CS300	¾"	1"	¾"	-	4.6	3.2	10.6
QS300	300	76	76	68	30	CS300	¾"	1"	¾"	-	5	3.5	10
Q400	370	71	71	88	30	CS300	¾"	1"	¾"	-	6	4	10
QS500	470	76	76	98	30	CS300	¾"	1"	¾"	-	5	3.5	10

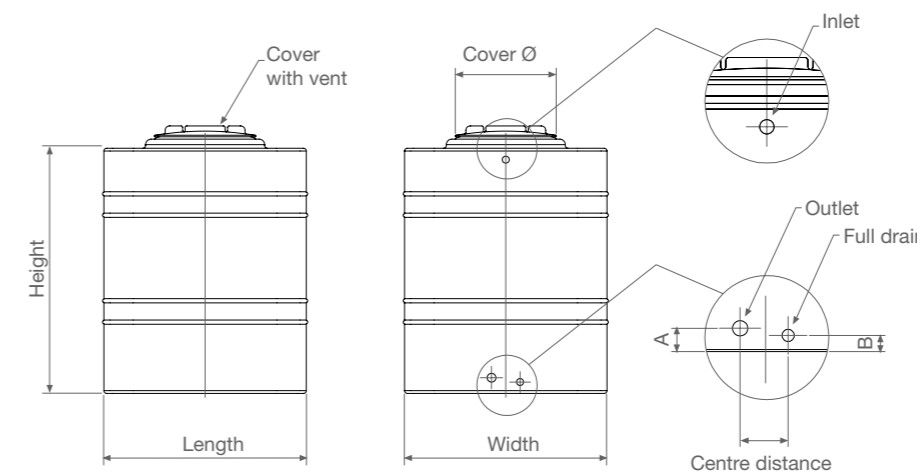

THREADED INSERTS IN BRASS
(on request)



See table on page 199

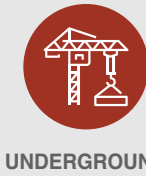
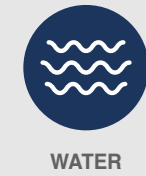

KITANK

[FIND OUT MORE](#)

OPTIMISATION OF WORKING VOLUMES DURING STORAGE AND TRANSPORT



Type
Above-ground tank

Applications
Storage of drinking and rain water, containment of foodstuffs (water, oil, wine)

Volumes
From 800 to 1300 litres

Installation
Placed directly on a flat supporting surface

Available colours

standard: blue, on request: grey, green, terracotta. MOCA logo.

Item	Useful volume l	Min. Ø cm	Max. Ø cm	H cm	Cover Ø cm	Cover
VA1000	800	86	115	135	30	CS300
VA1500	1300	100	130	150	30	CS300

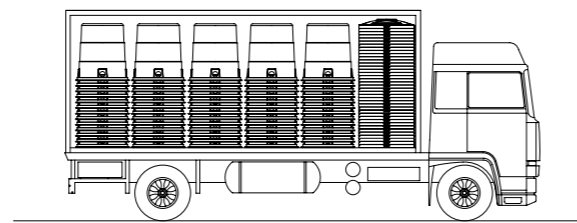
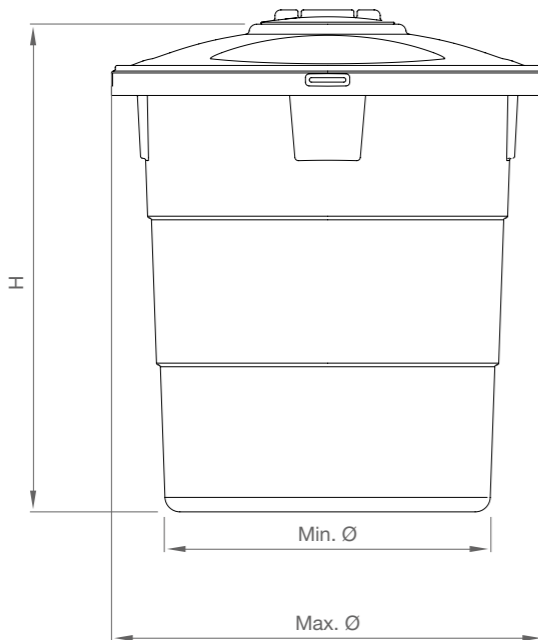

Example of transport for Rototec stackable tanks



How much can I save?

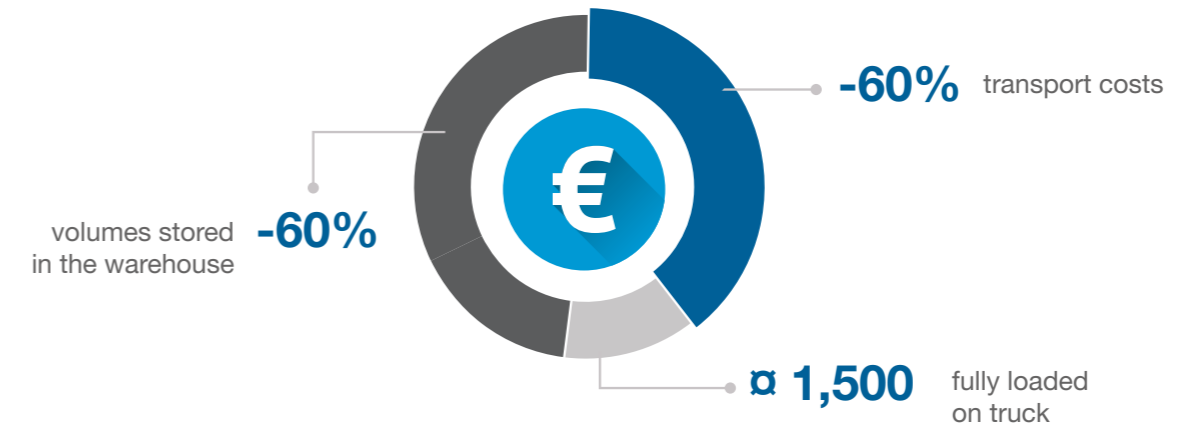

TECHNICAL CHARACTERISTICS

The new range of Rototec "KITank" tanks has been designed to reduce to a minimum the working volume during storage and transport. Thanks to the fact that the tanks can be dismantled and stacked it is possible to store and transport a large number of tanks in a very small space, thus reducing the working volume and above all the cost of transport.

The versatility of these tanks means they can be used to create drinking water or rainwater storage tanks, as well as for a wide range of domestic waste water treatment systems for small residential units: Grease separators, Septic tanks, IMHOFF BIOLOGICAL TANKS and anaerobic trickle filters.



ORCIOTTO

FIND OUT MORE

THREADED INSERTS IN GALVANISED BRASS (on request)

WATCH THE VIDEO



Type
Above-ground tank

Applications
Storage of drinking and rain water, containment of foodstuffs (water, oil, wine)

Volumes
From 300 to 1000 litres

Installation
Placed directly on a flat supporting surface

Available colours

● terracotta



Item	Useful volume l	Min. Ø cm	Max. Ø cm	H cm	Cover Ø cm	Cover	Outlet
OR300	315	475	815	960	300	CS300	3/4"
OR500	535	574	980	1135	300	CS300	3/4"
OR1000	1040	727	1236	1400	300	CS300	3/4"

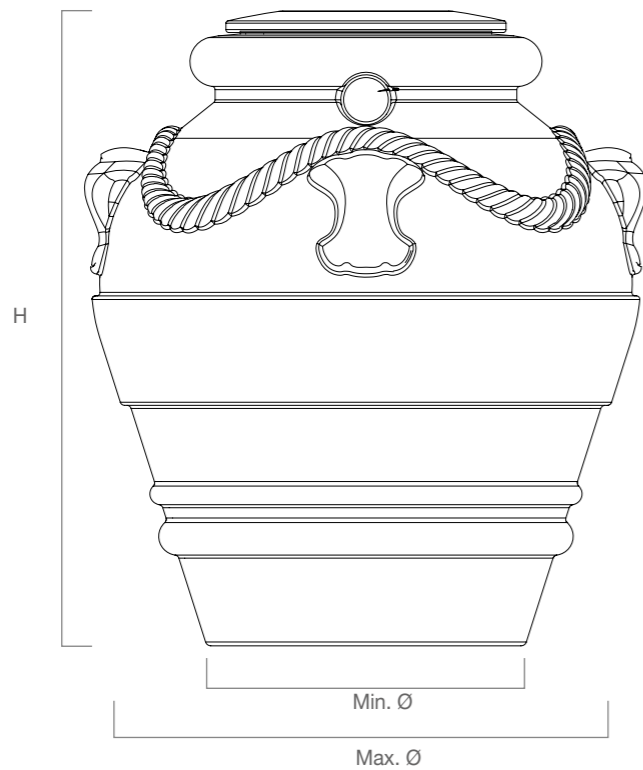

THREADED INSERTS IN BRASS (on request)



See table on page 199

Function

to provide a metal threaded female connection to replace the classic threaded unions co-moulded in the above-ground tanks.

Material

M-F threaded reducer fitting in galvanised brass, ideal for contact with potable water, with EPDM washer.

Application

The fitting is screwed into the threaded hole co-moulded in the tank, then tightened so that the washer forms a seal between the wall of the tank and the shoulder of the fitting itself. To tighten the fitting, use a spanner or, even better, a socket wrench.

Guarantee

The fitting is in fact a reducer, therefore the metal thread is always 1/4" smaller than the original co-moulded thread.

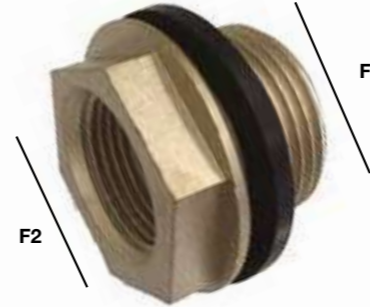

Item	F1 Inches	F2 Inches	Size of socket wrench for the installation mm
ROR7550	3/4	1/2	26
ROR1075	1"	3/4	36
ROR1512	1" 1/2	1" 1/4	50

Item	Tank Inlet Ø	Tank Outlet Ø	Full drain Ø	Insert Code number
V50	/	/	1/2"	No.1 ROR7550
VN150	1/2"	/	1/2"	No.2 ROR7550
VN300	1/2"	/	1/2"	No.2 ROR7550
VN500	1/2"	3/4"	1/2"	No.2 ROR7550 + No.1 ROR1075
VN1000	1/2"	3/4"	1/2"	No.2 ROR7550 + No.1 ROR1075
VN2000	3/4"	3/4"	1/2"	No.1 ROR7550 + No.2 ROR1075
VN3000	3/4"	3/4"	1/2"	No.1 ROR7550 + No.2 ROR1075
VN5000	3/4"	1" 1/4	3/4"	No.2 ROR1075 + No.1 ROR1512
V10000	/	/	/	/
PN500	1/2"	1/2"	/	No.2 ROR7550
PN1000	3/4"	3/4"	1/2"	No.1 ROR7550 + No.2 ROR1075
PN2000	3/4"	3/4"	1/2"	No.1 ROR7550 + No.2 ROR1075
PN3000	3/4"	3/4"	1/2"	No.1 ROR7550 + No.2 ROR1075
PN5000	3/4"	1" 1/4	3/4"	No.2 ROR1075 + No.1 ROR1512
PN7500	3/4"	1" 1/4	3/4"	No.2 ROR1075 + No.1 ROR1512
P11000	/	/	/	/
P15000	/	/	/	/
P20000	/	/	/	/
C300	1/2"	3/4"	1/2"	No.1 ROR1075 + No.2 ROR7550
C500	1/2"	/	1/2"	No.2 ROR7550
C1000	3/4"	3/4"	1/2"	No.1 ROR7550 + No.2 ROR1075
C1500	3/4"	3/4"	1/2"	No.1 ROR7550 + No.2 ROR1075
C2000	3/4"	3/4"	1/2"	No.1 ROR7550 + No.2 ROR1075
C3000	3/4"	3/4"	1/2"	No.1 ROR7550 + No.2 ROR1075
C5000	/	/	/	/
J1000	3/4"	3/4"	1/2"	No.1 ROR7550 + No.2 ROR1075
J2000	3/4"	3/4"	1/2"	No.1 ROR7550 + No.2 ROR1075
J3000	3/4"	3/4"	1/2"	No.1 ROR7550 + No.2 ROR1075
RV500	/	3/4"	1/2"	No.1 ROR7550 + No.1 ROR1075
RV1000	/	3/4"	1/2"	No.1 ROR7550 + No.1 ROR1075
B300	/	3/4"	1/2"	No.1 ROR7550 + No.1 ROR1075
B500	/	3/4"	1/2"	No.1 ROR7550 + No.1 ROR1075
Q200	1/2"	3/4"	1/2"	No.2 ROR7550 + No.1 ROR1075
QS300	1/2"	3/4"	1/2"	No.2 ROR7550 + No.1 ROR1075
Q400	1/2"	3/4"	1/2"	No.2 ROR7550 + No.1 ROR1075
QS500	1/2"	3/4"	1/2"	No.2 ROR7550 + No.1 ROR1075
S300	/	1/2"	/	No.1 ROR7550
S800	/	3/4"	/	No.1 ROR1075
ST300	/	3/4"	1/2"	No.1 ROR7550 + No.1 ROR1075
SS500	/	3/4"	1/2"	No.1 ROR7550 + No.1 ROR1075
OR300	/	1/2"	/	No.1 ROR7550
OR500	/	1/2"	/	No.1 ROR7550
OR1000	/	1/2"	/	No.1 ROR7550

Installation example

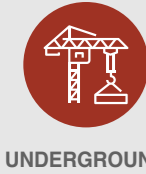
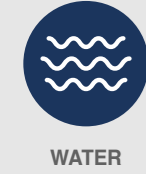
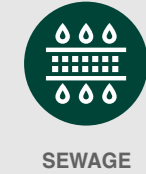

MODULAR FIREFIGHTING TANKS

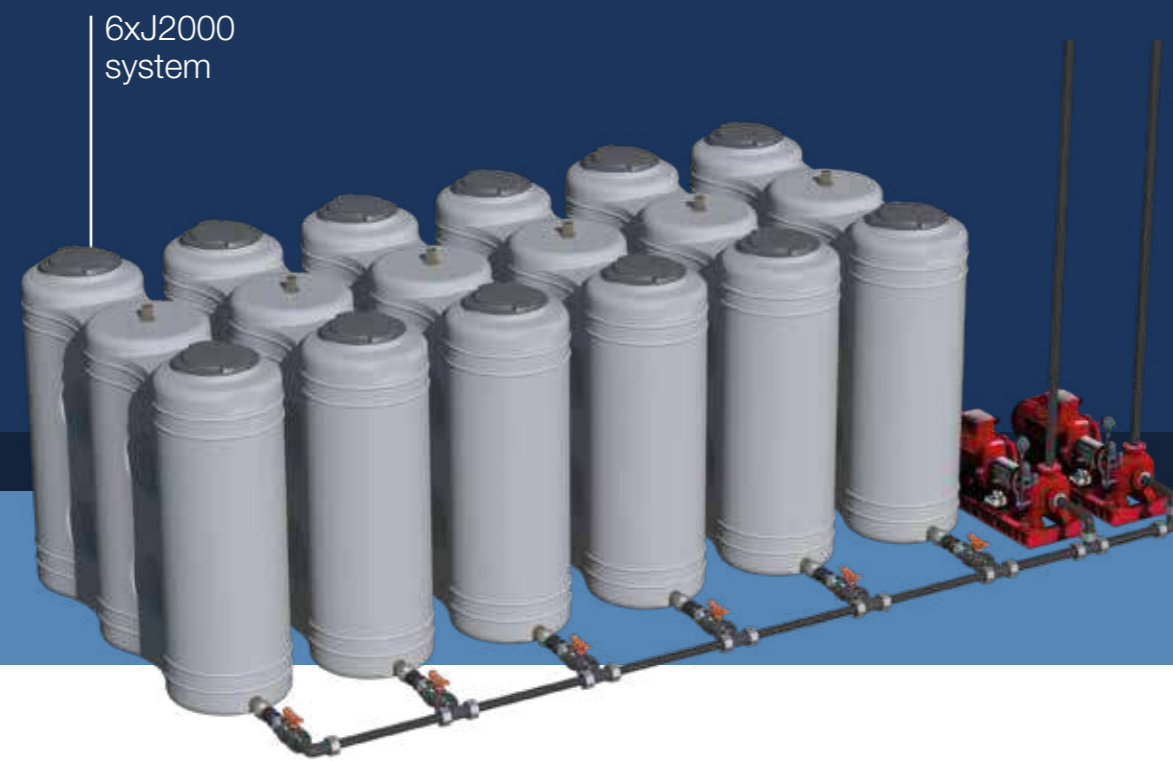

SPECIFICATIONS

The Jolly tank is the ideal solution for those needing a high performance, robust and versatile product. Designed to maximise the storage capacity, it ensures easy access and maintenance, along with a long service life. It is perfectly suited for applications where safety, hygiene, and functionality are critical — such as water supply and firefighting systems.

TECHNICAL CHARACTERISTICS

HIGH QUALITY MATERIAL

Made of linear high density polyethylene (LLDPE), a durable material containing additives to protect the tank from sunlight, simultaneously preventing the formation of algae and guaranteeing its durability and weather-resistance.

SUITABLE FOR SENSITIVE LIQUIDS:

Certified for potable water and for contact with food-quality liquids such as wine and oil, retaining their sensory characteristics (colour, smell, taste).

ECO-SUSTAINABLE AND RECYCLABLE:

The Jolly tank is 100% recyclable and contributes to environmental sustainability.

EASY ACCESS FOR MAINTENANCE:

The tank allows easy access to the interior for maintenance.

CONFIGURE YOUR SYSTEM WITH THE JOLLY MODEL TO ACHIEVE HIGH, CUSTOMIZABLE STORAGE CAPACITY, THAT CAN BE ADAPTED TO ANY NEED.



SEWAGE



WATER



UNDERGROUND INSTALLATION



- GREASE SEPARATORS
- IMHOFF BIOLOGICAL TANKS
- BIOLOGICAL SEPTIC TANKS
- ACTIVATED SLUDGE PLANT
- TRICKLE FILTERS
- SECONDARY TREATMENT PLANT
- DEPURBLOK
- DEPURO
- STORMWATER MANAGEMENT
- CAR WASH PLANTS
- LIFT STATIONS
- CHAMBERS
- TECHNICAL SECTION
- RAINWATER HARVESTING AND RE-USE SYSTEMS
- UNDERGROUND TANKS
- CONSTRUCTION SITE EQUIPMENT
- NON-STANDARD SOLUTIONS
- ABOVE-GROUND TANKS
- ACCESSORIES
- UNDERGROUND INSTALLATION
- OIL DISPOSAL UNIT
- PORTABLE TOILETS

6X2000L SYSTEM

4X3000L SYSTEM



Fig. 1

Fig. 2

Item	Capacity l	Length m	Width m	Height m	Cover Ø cm	Cover	Outlet vent	Outlet
J2000*	2000	2.33	0.68	1.9	30	CS300	-	1"
6XJ2000	12000	5.1	2.33	1.9	35	CS300	2"	2"

* Single model on page 189.

System consisting of 6 tanks model J2000. The accessories supplied as standard include by default the 2" plastic vent and the 2" plastic outlet pipe (figure 1). On request it is possible to add the kits illustrated below to connect them together, as shown (figure 2).

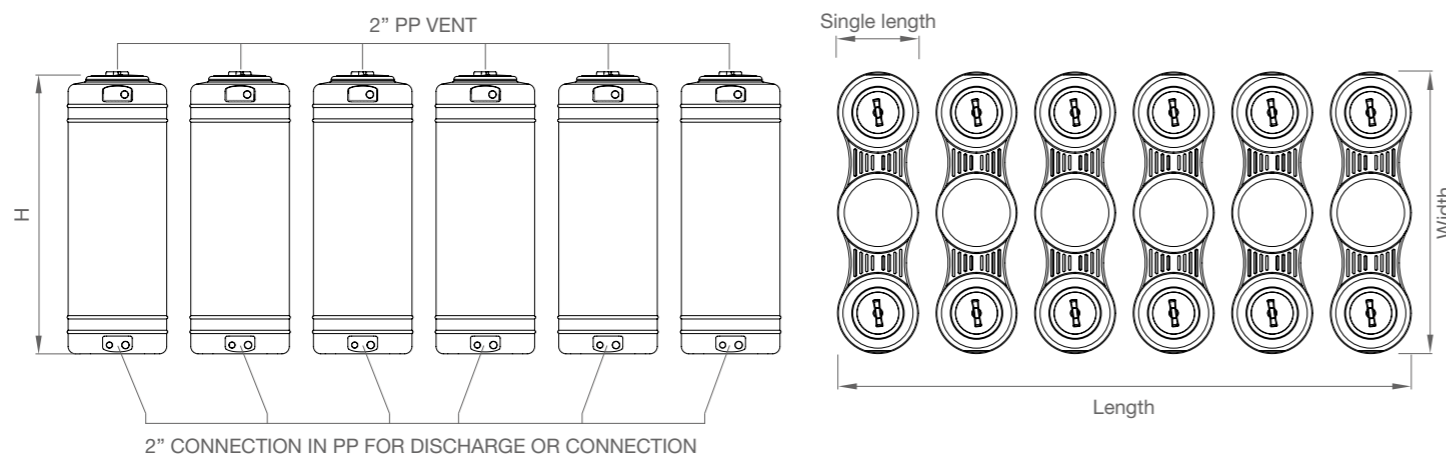

Item	Kit	Components
KIT 1		<ul style="list-style-type: none"> • Vibration damping joint • PVC ball valve • Elbow

Item	Kit	Components
KIT 2		<ul style="list-style-type: none"> • Vibration damping joint • PVC ball valve • Tee



Fig. 1

Fig. 2

Item	Capacity l	Length m	Width m	Height m	Cover Ø cm	Cover	Outlet vent	Outlet
J3000*	3000	2.60	0.8	2	40	CS400	-	1"
4XJ3000	12000	4	2.60	2	40	CS400	2"	2"

* Single model on page 189.

System consisting of 4 tanks model J3000. The accessories supplied as standard include by default the 2" plastic vent and the 2" plastic outlet pipe (figure 1). On request it is possible to add the kits illustrated below to connect them together, as shown (figure 2).

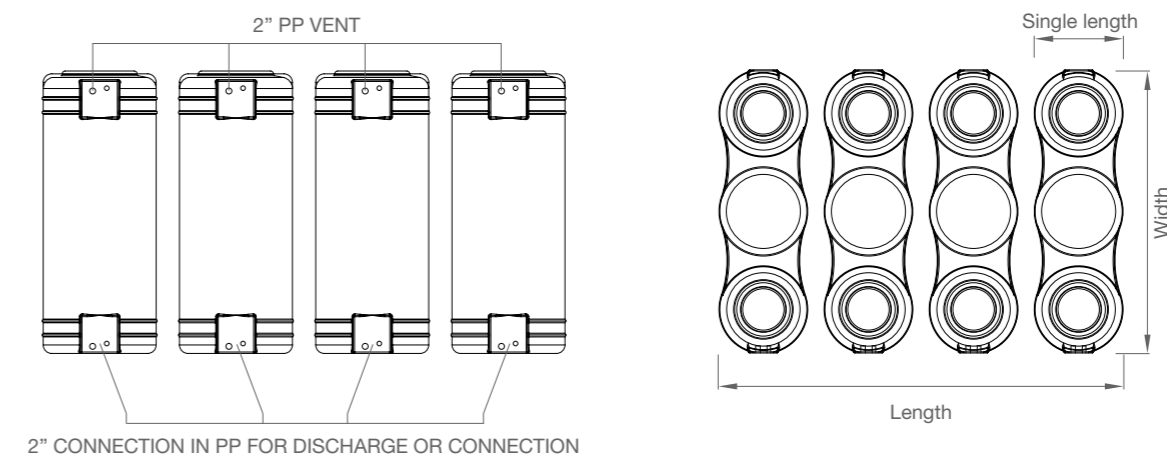

Item	Kit	Components
KIT 1		<ul style="list-style-type: none"> • Vibration damping joint • PVC ball valve • Elbow

Item	Kit	Components
KIT 2		<ul style="list-style-type: none"> • Vibration damping joint • PVC ball valve • Tee

UNDERGROUND TANKS

MODULAR

[FIND OUT MORE](#)

ONE-PIECE

[FIND OUT MORE](#)

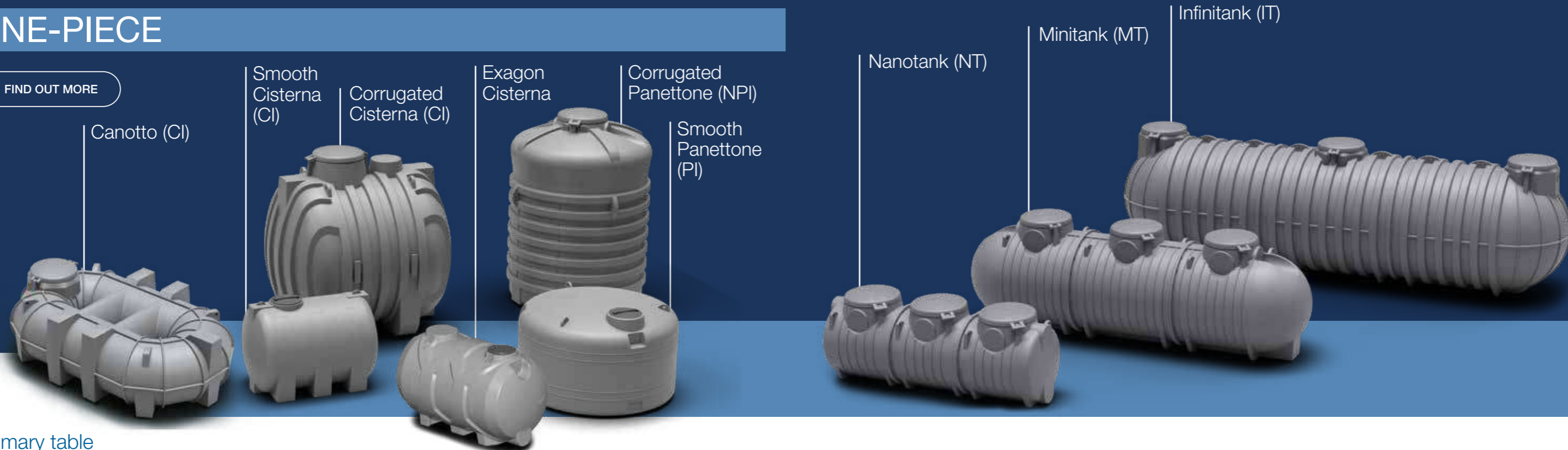

Summary table

Volumes l	SMOOTH CISTERNA Item	SMOOTH PANETTONE Item	CANOTTO Item	CORRUGATED CISTERNA Item	CORRUGATED PANETTONE Item	Volumes l	NANOTANK Item	MINITANK Item	INFINITANK Item
1000	CI1000	PI1000							
1500	CI1500								
2000	CI2000	PI2000				2000	NT2000		
3000			CI3500	CI3000	NPI3000	3000	NT3000		
4000					NPI4000	4000	NT4000		
5000			CI5300	CI5700	NPI5000	5000	NT5000		
6000			CI6500			6000	NT6000	MT6000	
8000			CI8300	CI8700	NPI8000				
10000				CI10700	NPI10000	9000		MT9000	
						11000	NTC10000		IT11000
						12000	NTC12000	MT12000	
						13000			IT13000
						15000		MT15000	IT15000
						18000		MT18000	IT18000
						20000			IT20000
						21000		MT21000	
						22000			IT22000
						25000			IT25000
						28000			IT28000
						30000			IT30000
						33000			IT33000
						35000			IT35000
						36000			IT36000
						40000			IT40000
						42000			IT42000
						45000			IT45000
						48000			IT48000
						50000			IT50000
						52000			IT52000

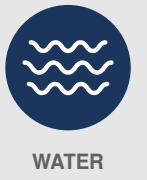

CISTERNA CORRUGATED UNDERGROUND TANKS

[FIND OUT MORE](#)



Type
Underground tank

Applications
Storage of drinking and rain water, containment of foodstuffs (water, oil, wine)

Volumes
From 3100 to 10700 litres

Installation
See chapter "Underground installation"

Available colours
standard ● marbled grey



Item	Capacity l	Length m	Width m	Height m	Cover Ø cm	Cover	A cm	B cm	C cm	D cm	Extensions (optional)	Lifting eye
CI3000	3100	2.09	1.50	1.72	63	TAP800	27	23	23	27	PP77	8
CI5700	5700	2.42	1.92	2.10	63	TAP800	35	30	30	35	PP77	8
CI8700	8500	2.66	2.25	2.36	63	TAP800	32	32	32	40	PP77	8
CI10700	10700	2.78	2.43	2.66	63	TAP800	32	32	32	40	PP77	8

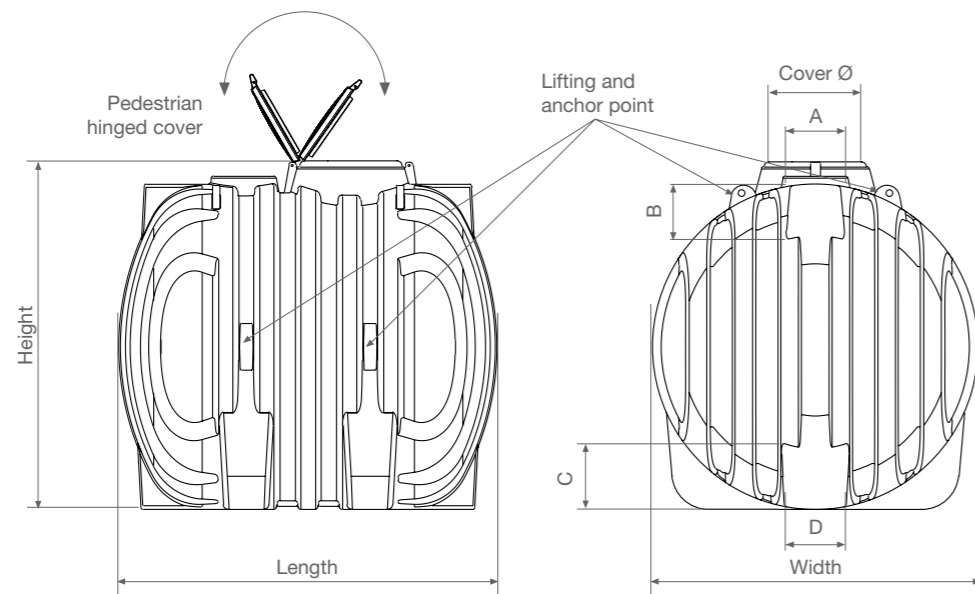

CANOTTO CORRUGATED UNDERGROUND TANKS

[FIND OUT MORE](#)



Type
Underground tank

Applications
Storage of drinking and rain water, containment of foodstuffs (water, oil, wine)

Volumes
From 3500 to 8300 litres

Installation
See chapter "Underground installation"

Available colours
standard ● marbled grey



Item	Capacity l	Length m	Width m	Height m	Cover Ø cm	Cover	Inlet	Outlet	Full drain	Extensions (optional)	Lifting eye
CI3500	3500	2.49	2.41	1.23	63	TAP800	-	-	-	PP77	4
CI5300	5300	3.65	2.41	1.23	63	TAP800	-	-	-	PP77	4
new CI6500	6300	3.97	2.41	1.23	63	TAP800	-	-	-	PP77	4
new CI8300	8300	5.13	2.41	1.23	63	TAP800	-	-	-	PP77	4

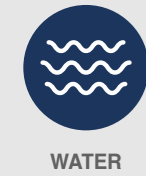
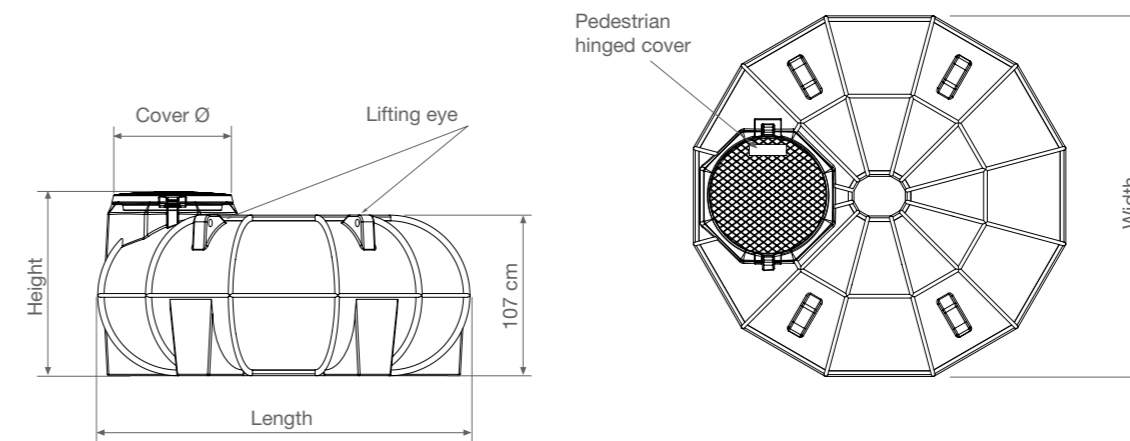

PANETTONE CORRUGATED UNDERGROUND TANKS

[FIND OUT MORE](#)



Type

Underground tank

Applications

Storage of drinking and rain water, containment of foodstuffs (water, oil, wine)

Volumes

From 3000 to 10000 litres

Installation

See chapter "Underground installation"

Available colours

standard ● marbled grey



Item	Capacity l	Ø m	Height m	Cover Ø cm	Cover	Inlet	Outlet	Full drain	Extensions (optional)	Lifting eye
NPI3000	3050	1.71	1.65	63	TAP800	-	-	-	PP77	4
NPI4000	4050	1.71	2.15	63	TAP800	-	-	-	PP77	4
NPI5000	5500	1.95	2.47	63	TAP800	-	-	-	PP77	4
NPI8000	7800	2.27	2.75	63	TAP800	-	-	-	PP77	4
NPI10000	9800	2.27	3.00	63	TAP800	-	-	-	PP77	4

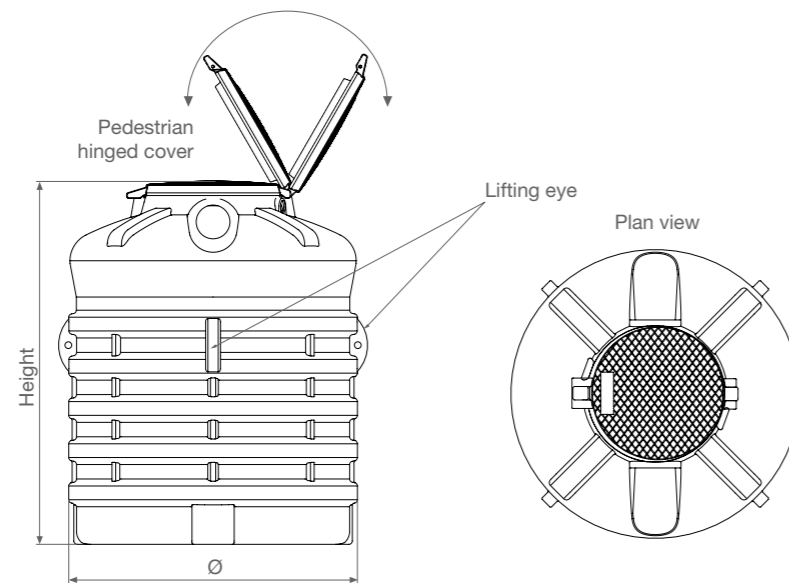

PANETTONE SMOOTH UNDERGROUND TANKS

[FIND OUT MORE](#)



Type

Underground tank

Applications

Storage of drinking and rain water, containment of foodstuffs (water, oil, wine)

Volumes

From 1000 to 2000 litres

Installation

See chapter "Underground installation"

Available colours

standard ● marbled grey



Item	Capacity l	Ø m	Height m	Cover Ø cm	Inlet	Outlet	Full drain	Cover	Extensions (optional)	A cm	B cm	Centre distance mm	Lifting eye
PI1000	1040	1.20	1.05	30	1"	1"	3/4"	CC300	PP35	9	5	110	3
PI2000	2075	1.50	1.33	40	1"	1"	3/4"	CC400	PP45	9	5	110	3

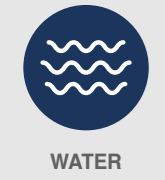
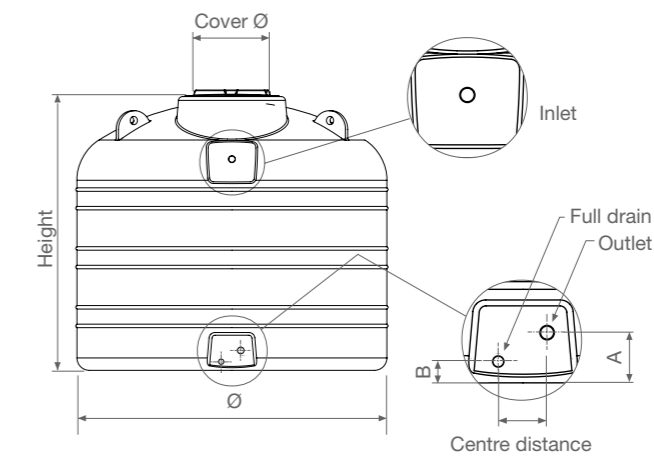
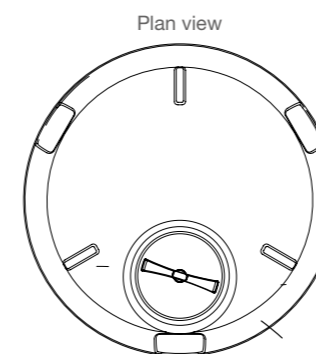

CISTERNA SMOOTH UNDERGROUND TANKS

[FIND OUT MORE](#)

UNDERGROUND TANK CISTERNA EXAGON



Type
Underground tank

Applications
Storage of drinking and rain water, containment of foodstuffs (water, oil, wine)

Volumes
From 1000 to 2000 litres

Installation
See chapter "Underground installation"

Available colours
standard ● marbled grey



Item	Capacity l	Length m	Width m	Height m	Cover Ø cm	Cover	Inlet	Outlet	Full drain	A cm	B cm	Centre distance mm	Extensions (optional)	Lifting eye
CI1000	1020	1.55	0.97	1.04	30	CC300	1"	1"	3/4"	7.80	4	11	PP35	-
CI1500	1665	1.70	1.15	1.22	40	CC400	1"	1"	3/4"	7	4	11	PP45	2
CI2000	2200	1.90	1.25	1.32	40	CC400	1"	1"	3/4"	8	4	12	PP45	2

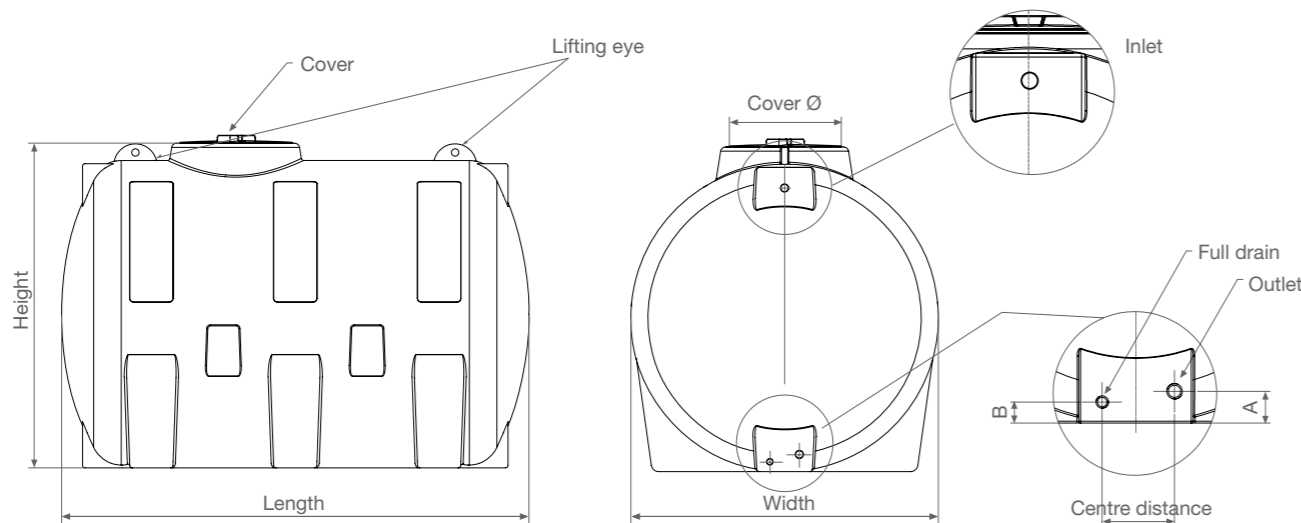

Type
Underground tank

Applications
Storage of drinking and rain water, containment of foodstuffs (water, oil, wine)

Volumes
From 2000 to 3100 litres

Installation
See chapter "Underground installation"

Available colours
standard ● marbled grey



Item	Model	Useful Volume l	Length mm	Width mm	Height mm	Ø Cap cm	Cover 1	Extensions (optional)	Lifting eye
XCI2000	Exagon	2060	2350	1220	1220	45	CC400	PP45	2
XCI3000	Exagon	3100	2450	1400	1450	45	CC400	PP45	4

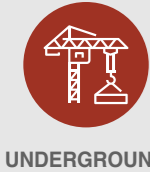
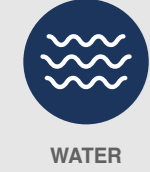
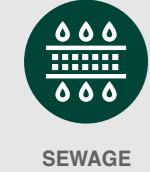
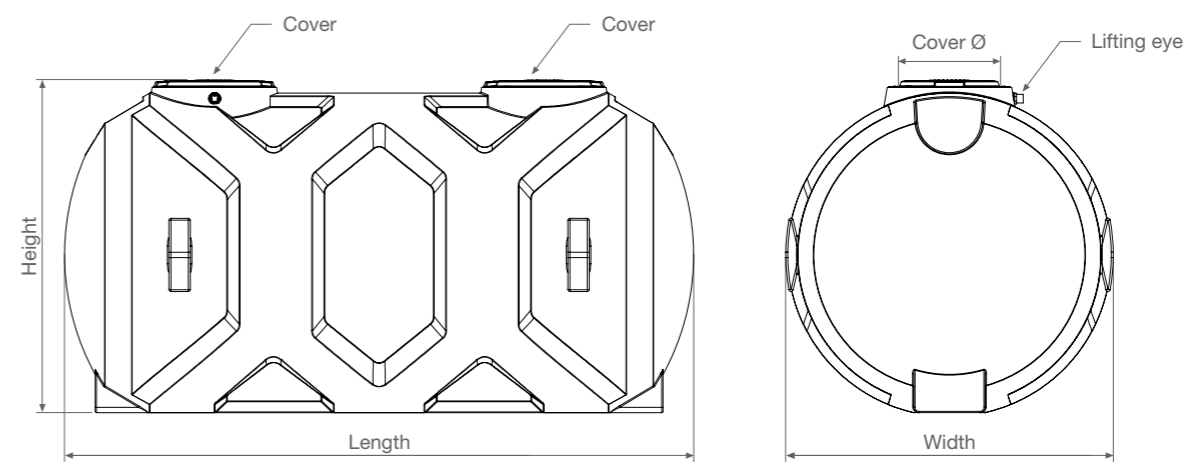

INFINITANK, MINITANK AND NANOTANK

Rototec's Infitank, Minitank and Nanotank underground tanks are modular units in which a number of one-piece, linear high density polyethylene (LLDPE) modules, manufactured using a rotomoulding process, are connected to each other to give large storage volumes. Thanks to the special pieces available (curve and Tee) the Infitank model can be used to create tanks of various shapes, allowing the best possible use of available space.

The various modules making up a tank are connected by means of a double system of bolting and electro-welding. Two modules are joined and fixed together by means of steel bolts, guaranteeing mechanical stability for the tank.

Water tightness, on the other hand, is guaranteed by a special polyethylene electro-welding procedure.

Polyethylene is a totally non-toxic material that does not foster the growth of algae in fluids contained in the tanks, making them ideal for storing potable water and other liquid foodstuffs. Furthermore, linear polyethylene also supports sudden changes in temperature (from -20 to + 80 °C) and is inert in the presence of chemical substances in the soil. For these reasons, there are no material oxidation or corrosion problems that would prejudice the mechanical characteristics and impermeability of the tanks. Furthermore, while possessing the same characteristics as other materials (cement, fibreglass, metal), tanks in polyethylene are much lighter, and as such transport, installation and maintenance are extremely simple and economic. Finally, polyethylene tanks can be bored when the need arises, for example when connecting tanks together, installing inlet/outlet pipes, overflows, etc.

NB: Rototec modular tanks must always be installed underground.

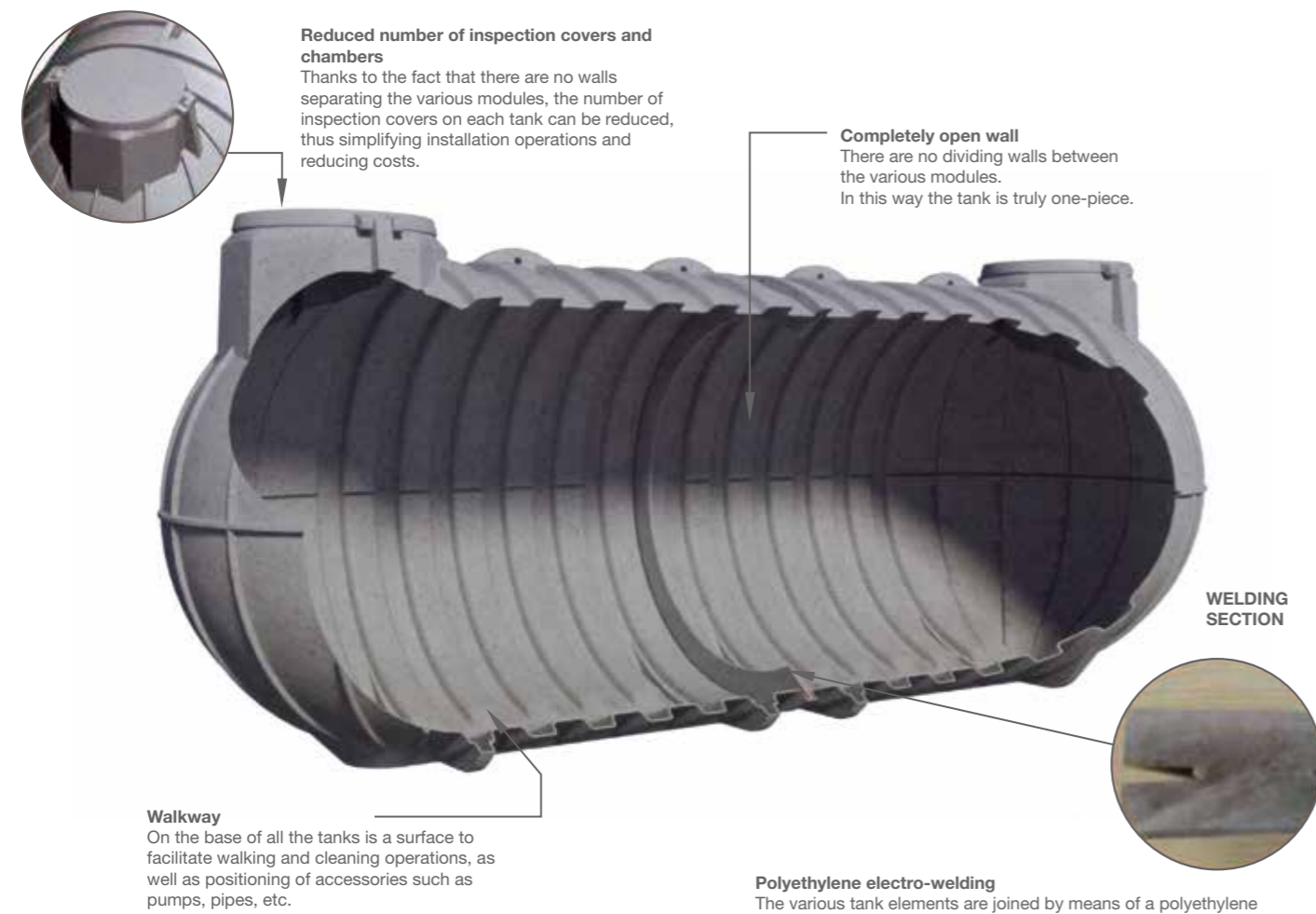

Reduced number of inspection covers and chambers
Thanks to the fact that there are no walls separating the various modules, the number of inspection covers on each tank can be reduced, thus simplifying installation operations and reducing costs.

Completely open wall
There are no dividing walls between the various modules. In this way the tank is truly one-piece.

WELDING SECTION

Walkway
On the base of all the tanks is a surface to facilitate walking and cleaning operations, as well as positioning of accessories such as pumps, pipes, etc.

Polyethylene electro-welding
The various tank elements are joined by means of a polyethylene electro-welding process. In this way the fluid in the tank never comes into contact with materials such as metal screws and flanges, rubber gaskets, etc., which might contaminate the fluid in the tank and also deteriorate over time.

INFINITANK / BASIC MODULES

HEAD

Item	Capacity l	Width m	Length m	Height m
TS 7500	7875	2.1	2.8	2.2
TS 5500	5500	2.1	2.2	2.2

CENTRAL

Item	Capacity l	Width m	Length m	Height m
CN 7000	7350	2.1	2.2	2.2

CURVE

Item	Capacity l	Width m	Length m	Height m
CR 7000	7350	2.1	2.4	2.2

TEE

Item	Capacity l	Width m	Length m	Height m
TE 8500	8925	2.1	2.3	2.4

MINITANK / BASIC MODULES

HEAD

Item	Capacity l	Width m	Length m	Height m
CTS3000	3005	1.55	1.93	1.71

CENTRAL

Item	Capacity l	Width m	Length m	Height m
CCN3000	3010	1.55	1.66	1.71

NANOTANK / BASIC MODULES

HEAD

Item	Capacity l	Width m	Length m	Height m
CTS1000	1050	1.15	1.17	1.32

CENTRAL

Item	Capacity l	Width m	Length m	Height m
CCN1000	1050	1.15	1.07	1.32



CURVE ^{new}

Item	Capacity l	Width m	Length m	Height m
CCR1000	950	1.24	1.24	1.32

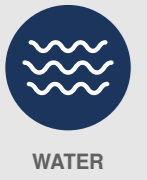

NANOTANK / NT

FIND OUT MORE

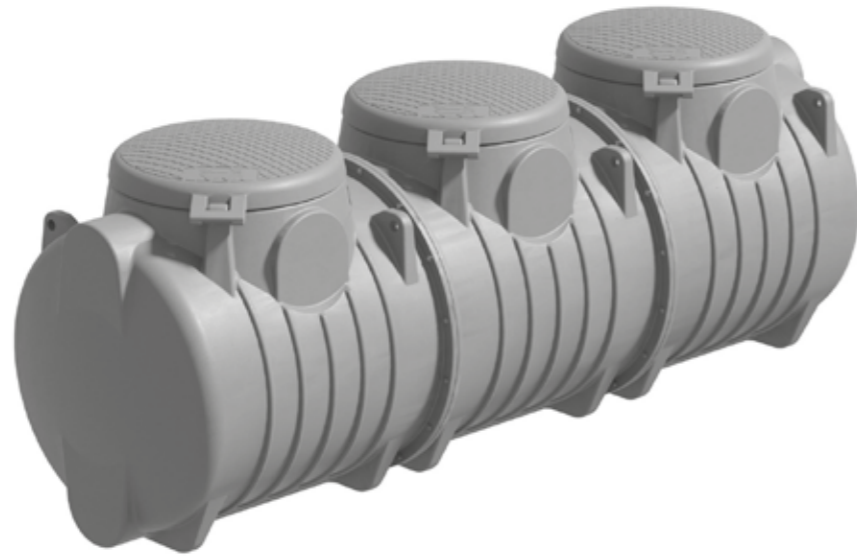

SEWAGE



WATER



UNDERGROUND INSTALLATION



Item	Useful volume l	Length m	Width m	Height m	Basic modules		No. Standard inspection covers	No. Optional inspection covers	Extensions (optional)
					CTS1000	CCN1000			
NT2000	2100	2.35	1.15	1.32	2	-	2	-	PP77

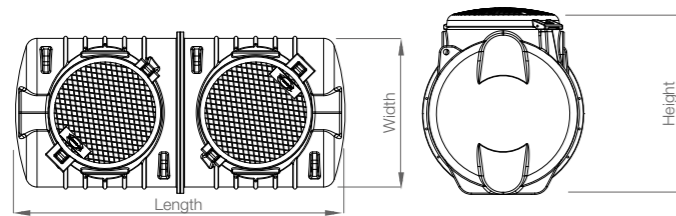

Item	Useful volume l	Length m	Width m	Height m	Basic modules		No. Standard inspection covers	No. Optional inspection covers	Extensions (optional)
					CTS1000	CCN1000			
NT3000	3150	3.42	1.15	1.32	2	1	2	1	PP77

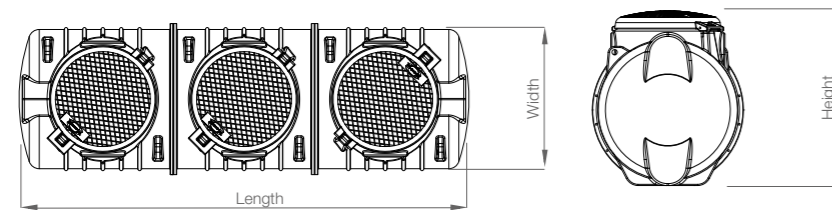

Item	Useful volume l	Length m	Width m	Height m	Basic modules		No. Standard inspection covers	No. Optional inspection covers	Extensions (optional)
					CTS1000	CCN1000			
NT4000	4200	4.5	1.15	1.32	2	2	2	2	PP77

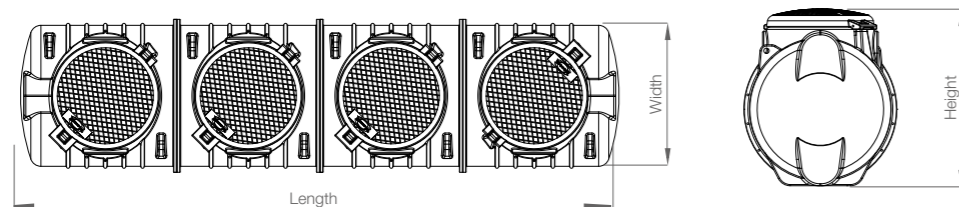

Item	Useful volume l	Length m	Width m	Height m	Basic modules		No. Standard inspection covers	No. Optional inspection covers	Extensions (optional)
					CTS1000	CCN1000			
NT5000	5250	5.57	1.15	1.32	2	3	2	3	PP77

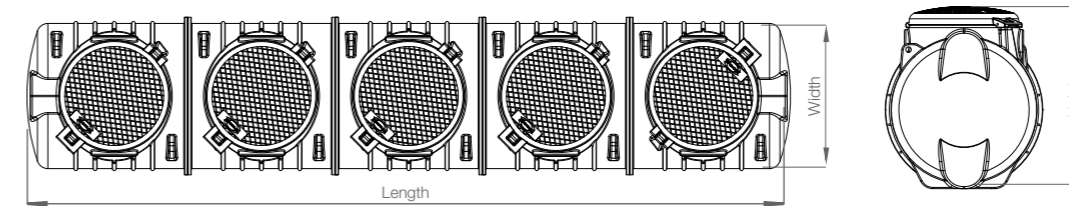

Item	Useful volume l	Length m	Width m	Height m	Basic modules		No. Standard inspection covers	No. Optional inspection covers	Extensions (optional)
					CTS1000	CCN1000			
NT6000	6300	6.65	1.15	1.32	2	4	2	4	PP77

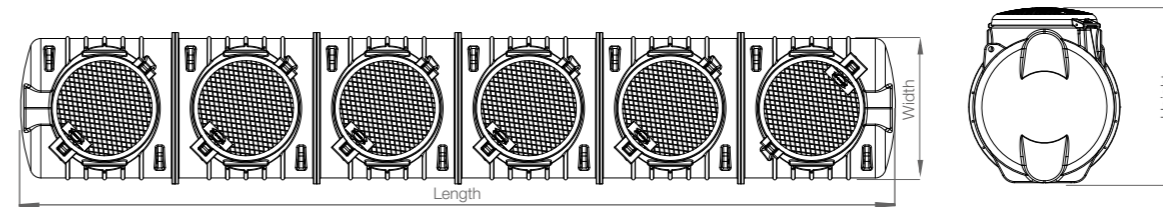

"U" SHAPE (NTU) NANOTANK

new

[FIND OUT MORE](#)



SEWAGE



WATER



UNDERGROUND INSTALLATION



Item	Useful volume l	Length m	Width m	Height m	Basic modules			No. Standard inspection covers	No. Optional inspection covers	Extensions (optional)
					CTS 1000	CCN 1000	CCR 1000			
NTU10000 330	10300	5.63	2.45	1.32	2	6	2	2	8	PP77

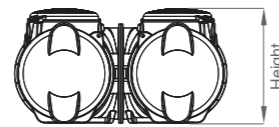
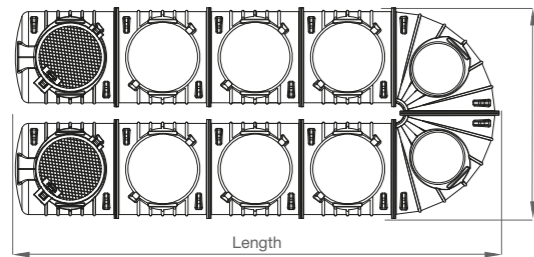

Item	Useful volume l	Length m	Width m	Height m	Basic modules			No. Standard inspection covers	No. Optional inspection covers	Extensions (optional)
					CTS 1000	CCN 1000	CCR 1000			
NTU12000 440	12400	6.7	2.45	1.32	2	8	2	2	10	PP77

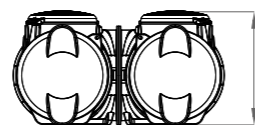
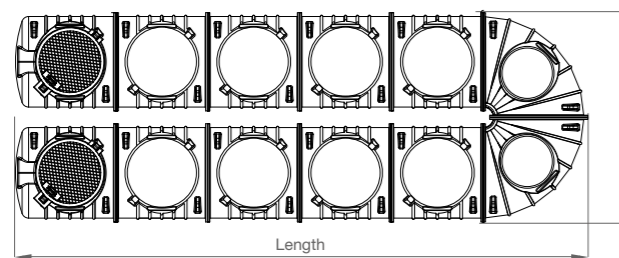

Item	Useful volume l	Length m	Width m	Height m	Basic modules			No. Standard inspection covers	No. Optional inspection covers	Extensions (optional)
					CTS 1000	CCN 1000	CCR 1000			
NTU14000 550	14500	7.78	2.45	1.32	2	10	2	2	12	PP77

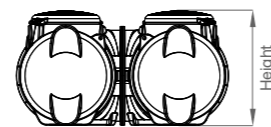
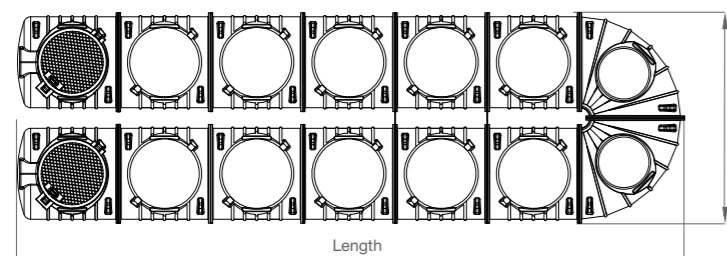

Item	Useful volume l	Length m	Width m	Height m	Basic modules			No. Standard inspection covers	No. Optional inspection covers	Extensions (optional)
					CTS 1000	CCN 1000	CCR 1000			
NTU16000 660	16600	8.85	2.45	1.32	2	12	2	2	14	PP77

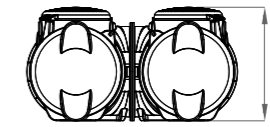
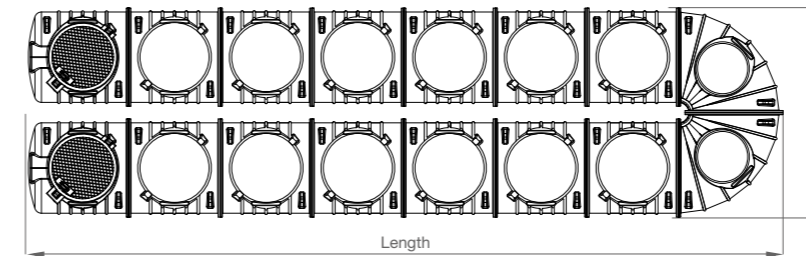

Item	Useful volume l	Length m	Width m	Height m	Basic modules			No. Standard inspection covers	No. Optional inspection covers	Extensions (optional)
					CTS 1000	CCN 1000	CCR 1000			
NTU18000 770	18700	9.93	2.45	1.32	2	14	2	2	16	PP77

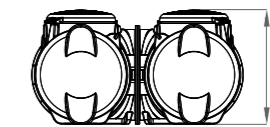
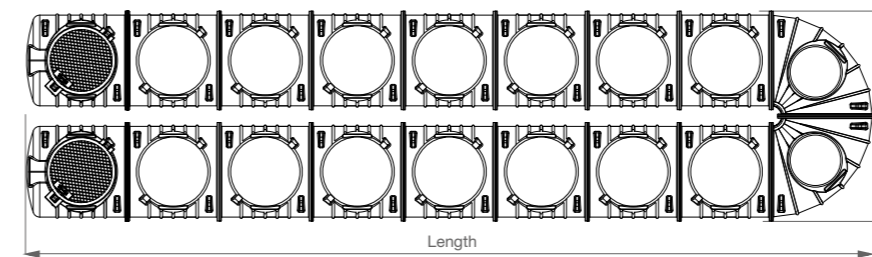

Item	Useful volume l	Length m	Width m	Height m	Basic modules			No. Standard inspection covers	No. Optional inspection covers	Extensions (optional)
					CTS 1000	CCN 1000	CCR 1000			
NTU20000 880	20800	11	2.45	1.32	2	16	2	2	18	PP77

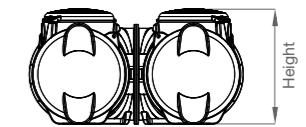
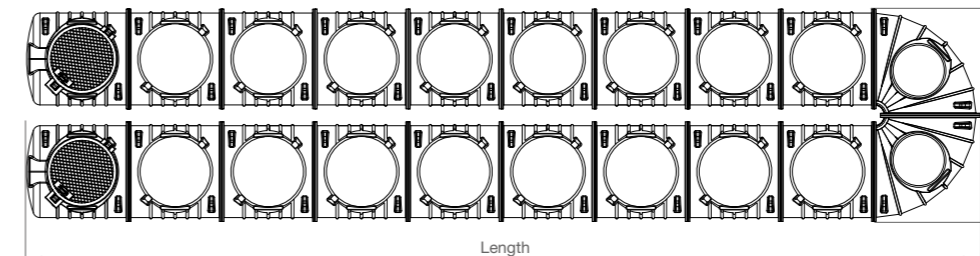

Item	Useful volume l	Length m	Width m	Height m	Basic modules			No. Standard inspection covers	No. Optional inspection covers	Extensions (optional)
					CTS 1000	CCN 1000	CCR 1000			
NTU22000 990	22900	12.08	2.45	1.32	2	18	2	2	20	PP77

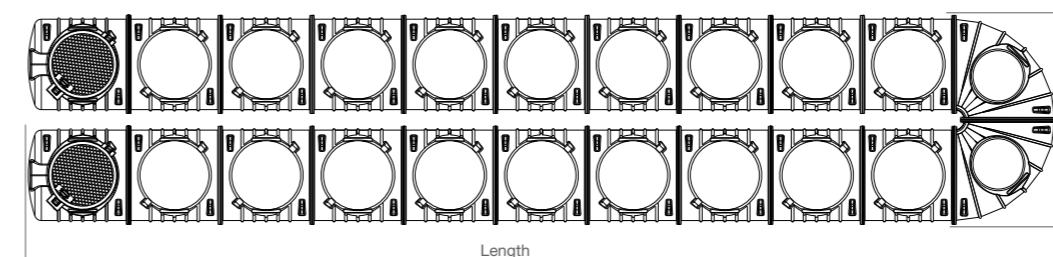

CANOTTO (NTC) NANOTANK

new

[FIND OUT MORE](#)



N.B.: For larger sizes, please contact the Technical Office.

Item	Useful volume	Length m	Width m	Height m	Basic modules			No. Standard inspection covers	No. Optional inspection covers	Extensions (optional)
					CTS 1000	CCN 1000	CCR 1000			
NTC10000	10100	5.68	2.45	1.32	-	6	4	2	4	PP77

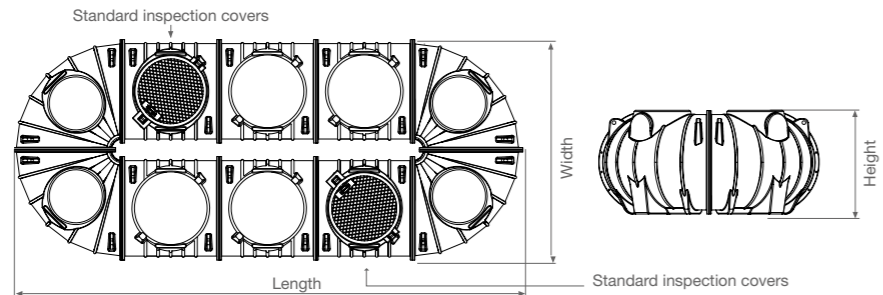

Item	Useful volume	Length m	Width m	Height m	Basic modules			No. Standard inspection covers	No. Optional inspection covers	Extensions (optional)
					CTS 1000	CCN 1000	CCR 1000			
NTC12000	12200	6.75	2.45	1.32	-	8	4	2	6	PP77

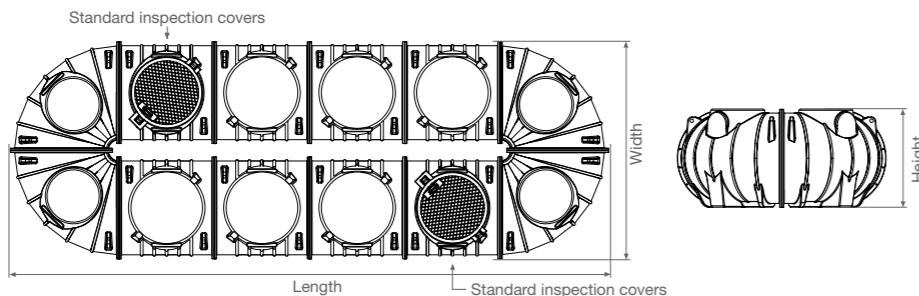

Item	Useful volume	Length m	Width m	Height m	Basic modules			No. Standard inspection covers	No. Optional inspection covers	Extensions (optional)
					CTS 1000	CCN 1000	CCR 1000			
NTC14000	14300	7.83	2.45	1.32	-	10	4	2	12	PP77

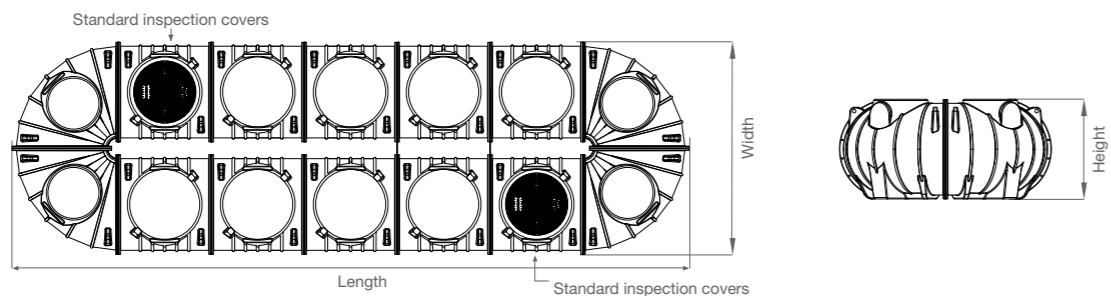

Item	Useful volume	Length m	Width m	Height m	Basic modules			No. Standard inspection covers	No. Optional inspection covers	Extensions (optional)
					CTS 1000	CCN 1000	CCR 1000			
NTC16000	16400	8.9	2.45	1.32	-	12	4	2	14	PP77

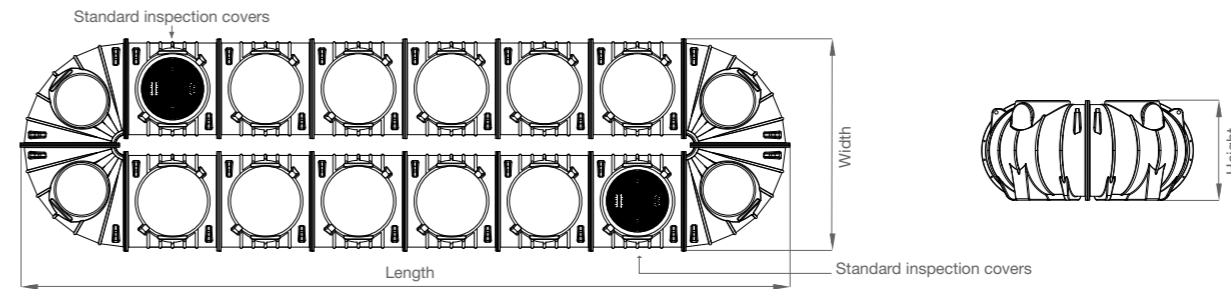

Item	Useful volume	Length m	Width m	Height m	Basic modules			No. Standard inspection covers	No. Optional inspection covers	Extensions (optional)
					CTS 1000	CCN 1000	CCR 1000			
NTC18000	18500	9.98	2.45	1.32	-	14	4	2	16	PP77

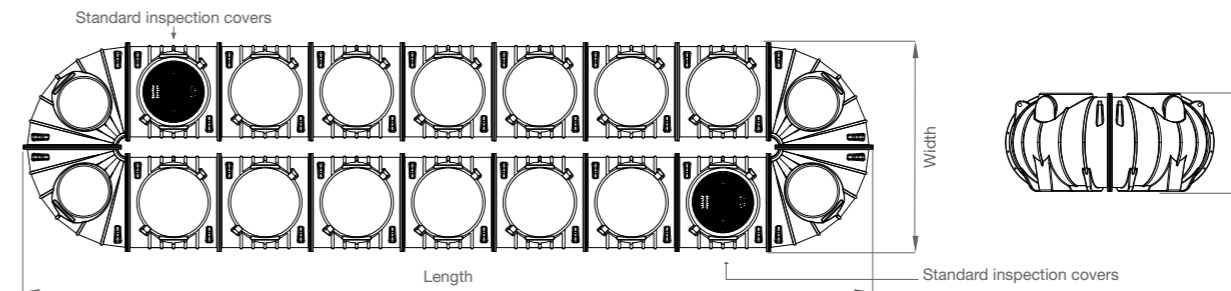

Item	Useful volume	Length m	Width m	Height m	Basic modules			No. Standard inspection covers	No. Optional inspection covers	Extensions (optional)
					CTS 1000	CCN 1000	CCR 1000			
NTC20000	20600	11.05	2.45	1.32	-	16	4	2	18	PP77

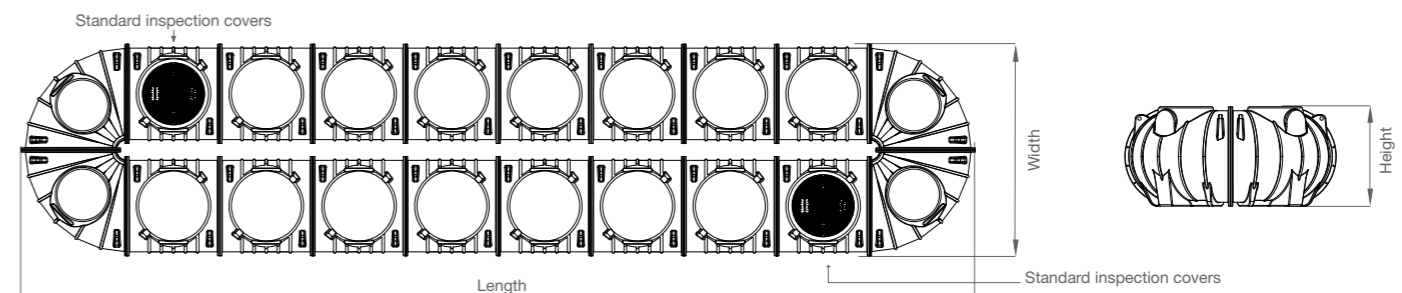

Item	Useful volume	Length m	Width m	Height m	Basic modules			No. Standard inspection covers	No. Optional inspection covers	Extensions (optional)
					CTS 1000	CCN 1000	CCR 1000			
NTC22000	22700	12.13	2.45	1.32	-	18	4	2	20	PP77

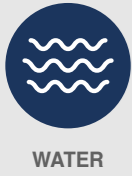
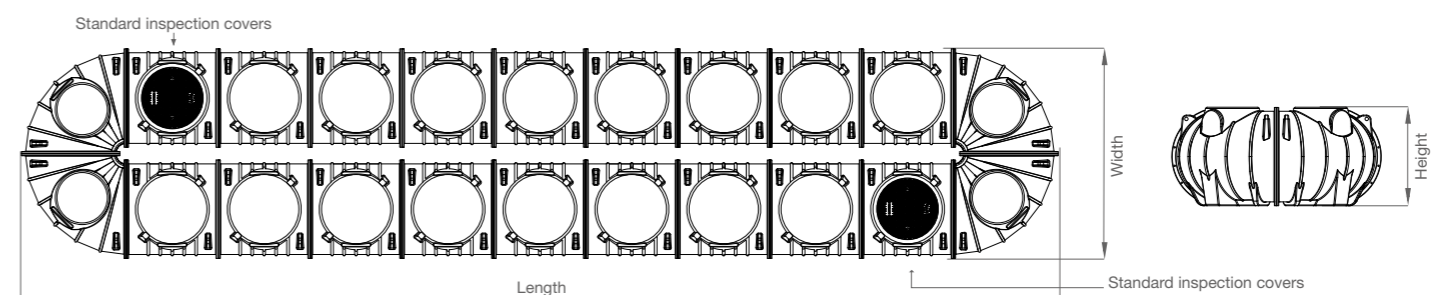

MINITANK / MT

[FIND OUT MORE](#)

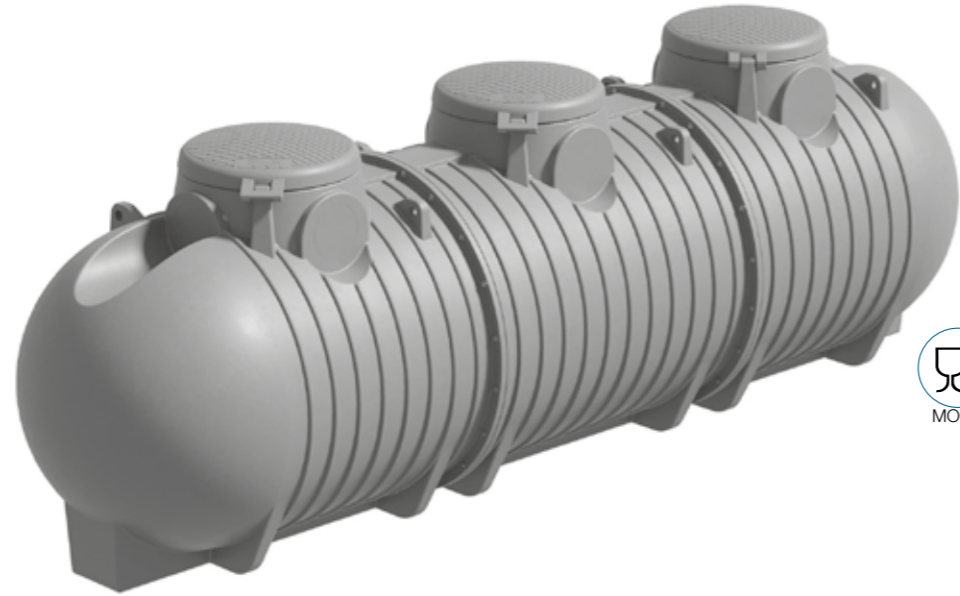

Item	Useful volume l	Length m	Width m	Height m	Basic modules		No. Standard inspection covers	No. Optional inspection covers	Extensions (optional)
					CTS3000	CCN3000			
MT6000	6010	3.87	1.55	1.71	2	-	2	-	PP77

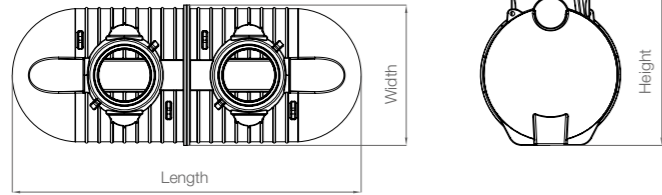

Item	Useful volume l	Length m	Width m	Height m	Basic modules		No. Standard inspection covers	No. Optional inspection covers	Extensions (optional)
					CTS3000	CCN3000			
MT9000	9020	5.52	1.55	1.71	2	1	2	1	PP77

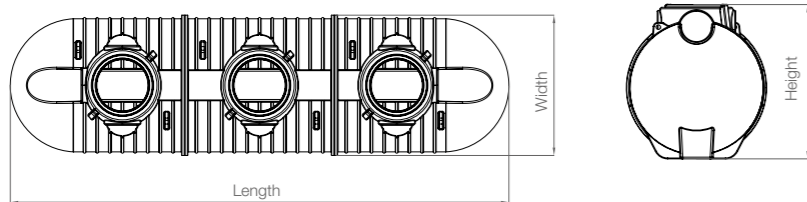

Item	Useful volume l	Length m	Width m	Height m	Basic modules		No. Standard inspection covers	No. Optional inspection covers	Extensions (optional)
					CTS3000	CCN3000			
MT12000	12030	7.18	1.55	1.71	2	2	2	2	PP77

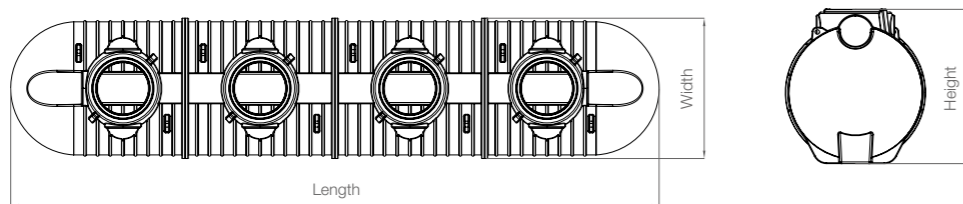

Item	Useful volume l	Length m	Width m	Height m	Basic modules		No. Standard inspection covers	No. Optional inspection covers	Extensions (optional)
					CTS3000	CCN3000			
MT15000	15040	8.84	1.55	1.71	2	3	2	3	PP77

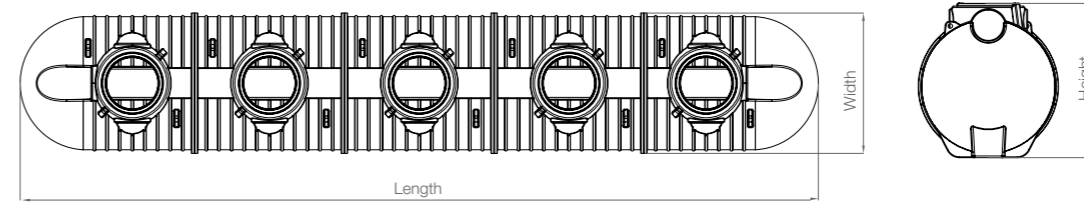

Item	Useful volume l	Length m	Width m	Height m	Basic modules		No. Standard inspection covers	No. Optional inspection covers	Extensions (optional)
					CTS3000	CCN3000			
MT18000	18050	10.51	1.55	1.71	2	4	2	4	PP77

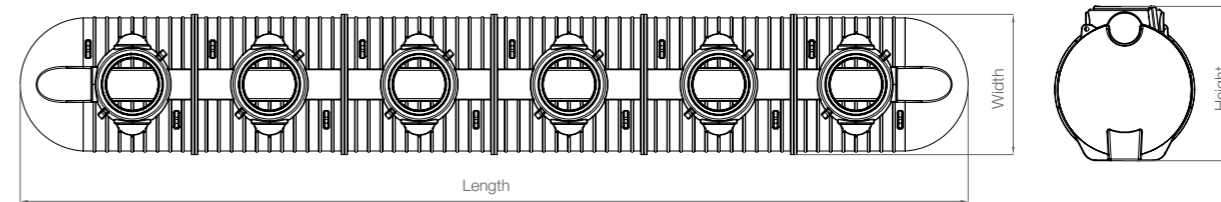

Item	Useful volume l	Length m	Width m	Height m	Basic modules		No. Standard inspection covers	No. Optional inspection covers	Extensions (optional)
					CTS3000	CCN3000			
MT21000	21060	12.17	1.55	1.71	2	5	2	5	PP77

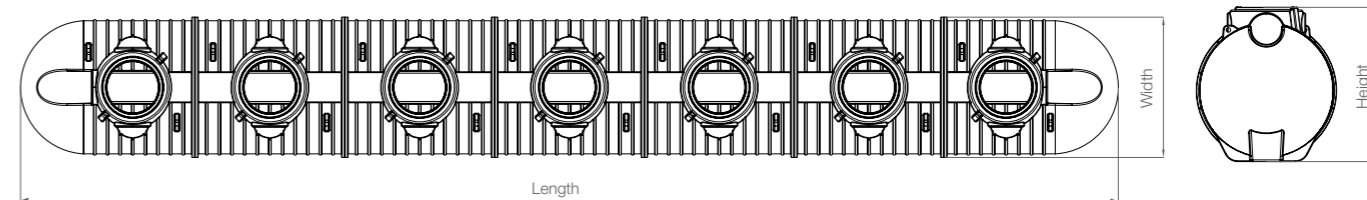

INFINITANK / LINEAR (IT)

[FIND OUT MORE](#)

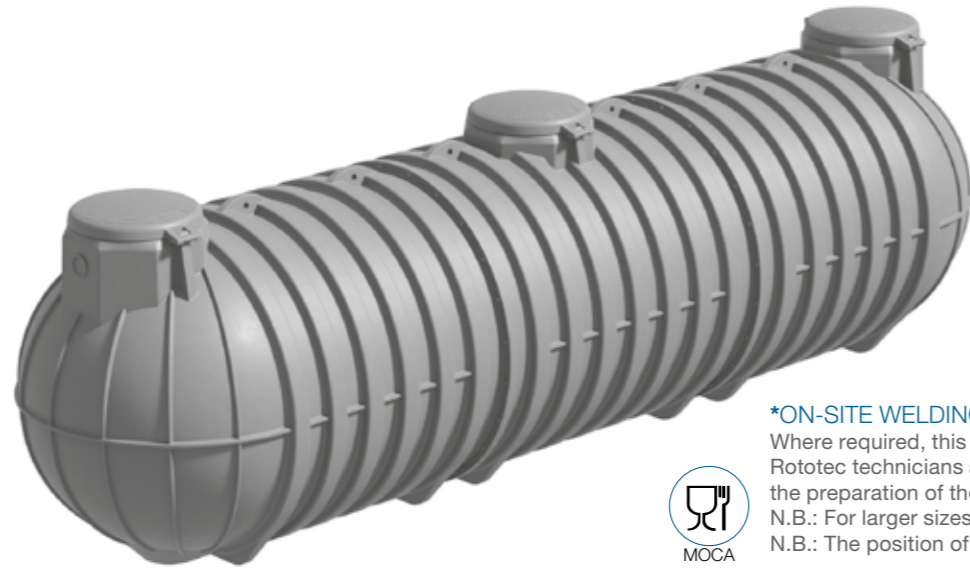

***ON-SITE WELDING**
 Where required, this will be carried out by specialist Rototec technicians and the cost will be calculated during the preparation of the offer.
 N.B.: For larger sizes, please contact the Technical Office.
 N.B.: The position of the asterisk is purely indicative.



Item	Useful volume l	Length m	Width m	Height m	Basic modules					No. Standard inspection covers	No. Optional inspection covers	Extensions (optional)	On-site welding
					TS 5500	TS 7500	CN 7000	CR 7000	TE 8500				
IT11000	11000	4.42	2.1	2.2	2	-	-	-	-	2	-	PP77	-

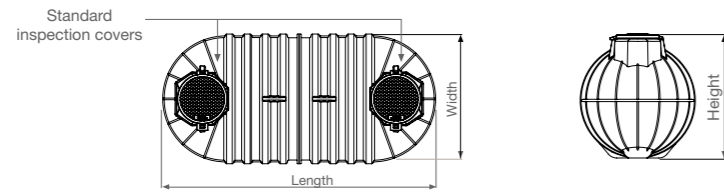

Item	Useful volume l	Length m	Width m	Height m	Basic modules					No. Standard inspection covers	No. Optional inspection covers	Extensions (optional)	On-site welding
					TS 5500	TS 7500	CN 7000	CR 7000	TE 8500				
IT13000	13375	5.01	2.1	2.2	1	1	-	-	-	2	-	PP77	-

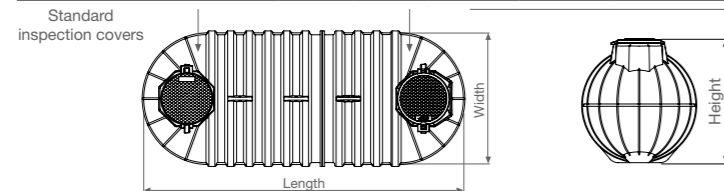

Item	Useful volume l	Length m	Width m	Height m	Basic modules					No. Standard inspection covers	No. Optional inspection covers	Extensions (optional)	On-site welding
					TS 5500	TS 7500	CN 7000	CR 7000	TE 8500				
IT15000	15750	5.62	2.1	2.2	-	2	-	-	-	2	-	PP77	-

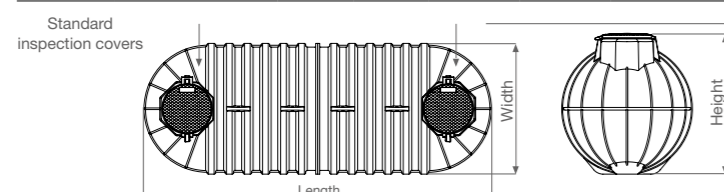

Item	Useful volume l	Length m	Width m	Height m	Basic modules					No. Standard inspection covers	No. Optional inspection covers	Extensions (optional)	On-site welding
					TS 5500	TS 7500	CN 7000	CR 7000	TE 8500				
IT18000	18350	6.68	2.1	2.2	2	0	1	-	-	2	-	PP77	-

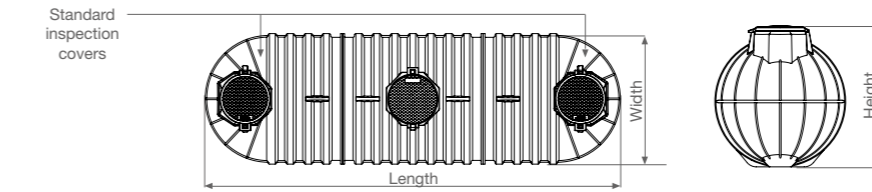

Item	Useful volume l	Length m	Width m	Height m	Basic modules					No. Standard inspection covers	No. Optional inspection covers	Extensions (optional)	On-site welding
					TS 5500	TS 7500	CN 7000	CR 7000	TE 8500				
IT20000	20725	7.27	2.1	2.2	1	1	1	-	-	2	-	PP77	-

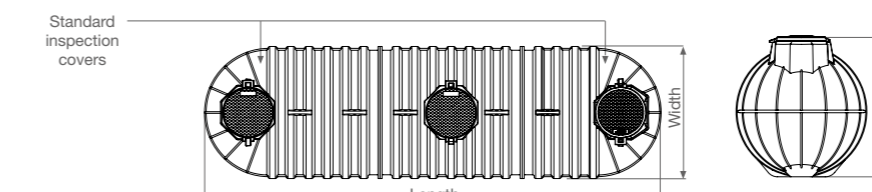

Item	Useful volume l	Length m	Width m	Height m	Basic modules					No. Standard inspection covers	No. Optional inspection covers	Extensions (optional)	On-site welding
					TS 5500	TS 7500	CN 7000	CR 7000	TE 8500				
IT22000	23100	7.88	2.1	2.2	-	2	1	-	-	2	-	PP77	-

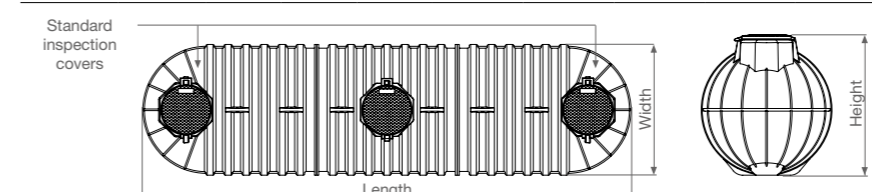

Item	Useful volume l	Length m	Width m	Height m	Basic modules					No. Standard inspection covers	No. Optional inspection covers	Extensions (optional)	On-site welding
					TS 5500	TS 7500	CN 7000	CR 7000	TE 8500				
IT25000	25700	8.94	2.1	2.2	2	-	2	-	-	2	-	PP77	-

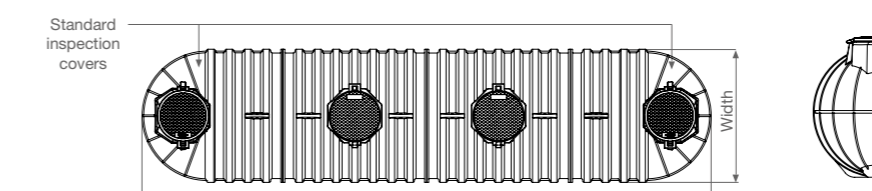

Item	Useful volume l	Length m	Width m	Height m	Basic modules					No. Standard inspection covers	No. Optional inspection covers	Extensions (optional)	On-site welding
					TS 5500	TS 7500	CN 7000	CR 7000	TE 8500				
IT28000	28075	9.53	2.1	2.2	1	1	2	-	-	2	-	PP77	-

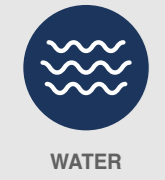
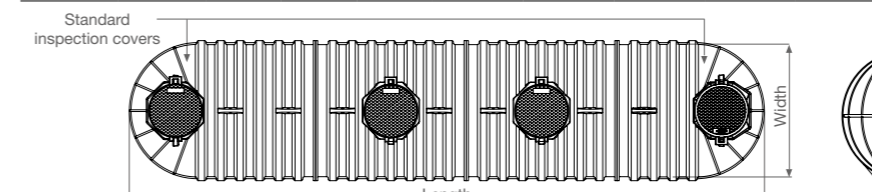



SEWAGE



WATER



UNDERGROUND INSTALLATION



Item	Useful volume l	Length m	Width m	Height m	Basic modules					No. Standard inspection covers	No. Optional inspection covers	Extensions (optional)	On-site welding
					TS 5500	TS 7500	CN 7000	CR 7000	TE 8500				
IT30000	30450	10.14	2.1	2.2	-	2	2	-	-	2	2	PP77	-

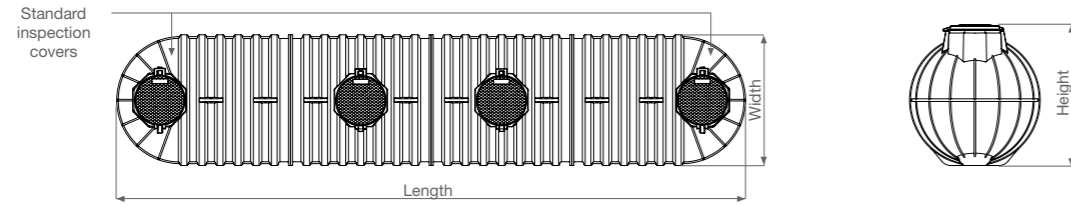

Item	Useful volume l	Length m	Width m	Height m	Basic modules					No. Standard inspection covers	No. Optional inspection covers	Extensions (optional)	On-site welding
					TS 5500	TS 7500	CN 7000	CR 7000	TE 8500				
IT33000	33050	11.20	2.1	2.2	2	-	3	-	-	2	3	PP77	-

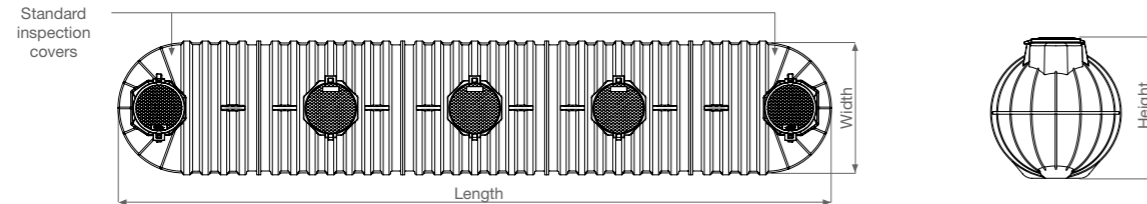

Item	Useful volume l	Length m	Width m	Height m	Basic modules					No. Standard inspection covers	No. Optional inspection covers	Extensions (optional)	On-site welding
					TS 5500	TS 7500	CN 7000	CR 7000	TE 8500				
IT35000	35425	11.79	2.1	2.2	1	1	3	-	-	2	3	PP77	-

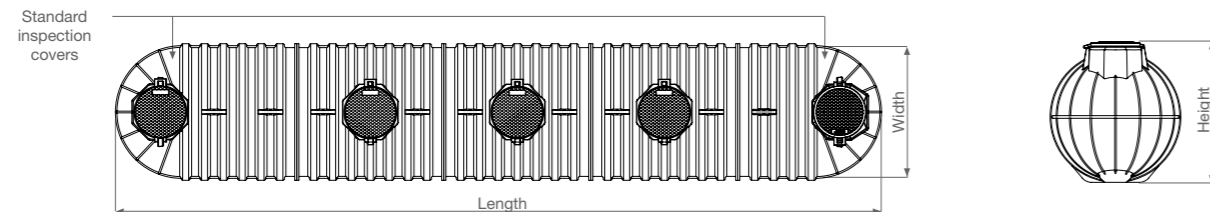

Item	Useful volume l	Length m	Width m	Height m	Basic modules					No. Standard inspection covers	No. Optional inspection covers	Extensions (optional)	On-site welding
					TS 5500	TS 7500	CN 7000	CR 7000	TE 8500				
IT36000	37800	12.4	2.1	2.2	0	2	3	-	-	2	3	PP77	-

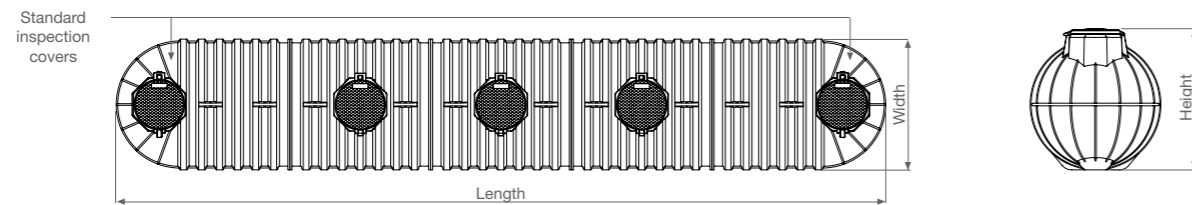

Item	Useful volume l	Length m	Width m	Height m	Basic modules					No. Standard inspection covers	No. Optional inspection covers	Extensions (optional)	On-site welding
					TS 5500	TS 7500	CN 7000	CR 7000	TE 8500				
IT40000	40400	13.46	2.1	2.2	2	-	4	-	-	2	4	PP77	-

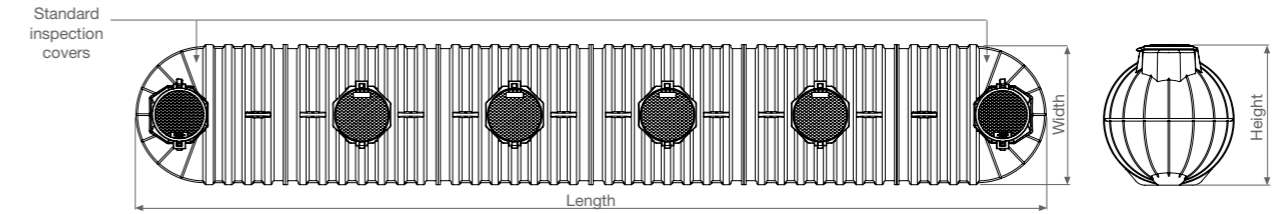

Item	Useful volume l	Length m	Width m	Height m	Basic modules					No. Standard inspection covers	No. Optional inspection covers	Extensions (optional)	On-site welding
					TS 5500	TS 7500	CN 7000	CR 7000	TE 8500				
IT42000	42775	14.05	2.1	2.2	1	1	4	-	-	2	4	PP77	1

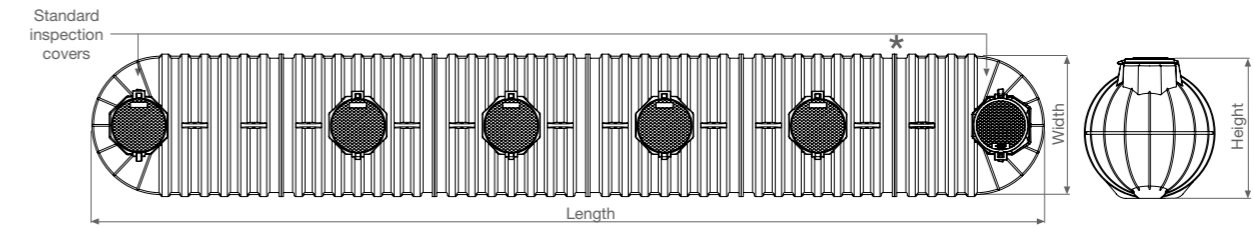

Item	Useful volume l	Length m	Width m	Height m	Basic modules					No. Standard inspection covers	No. Optional inspection covers	Extensions (optional)	On-site welding
					TS 5500	TS 7500	CN 7000	CR 7000	TE 8500				
IT45000	45150	14.66	2.1	2.2	-	2	4	-	-	2	4	PP77	1

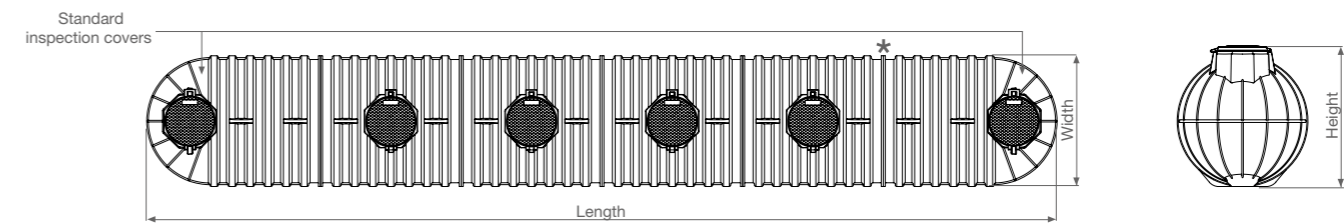

Item	Useful volume l	Length m	Width m	Height m	Basic modules					No. Standard inspection covers	No. Optional inspection covers	Extensions (optional)	On-site welding
					TS 5500	TS 7500	CN 7000	CR 7000	TE 8500				
IT48000	47750	15.72	2.1	2.2	2	-	5	-	-	2	5	PP77	1

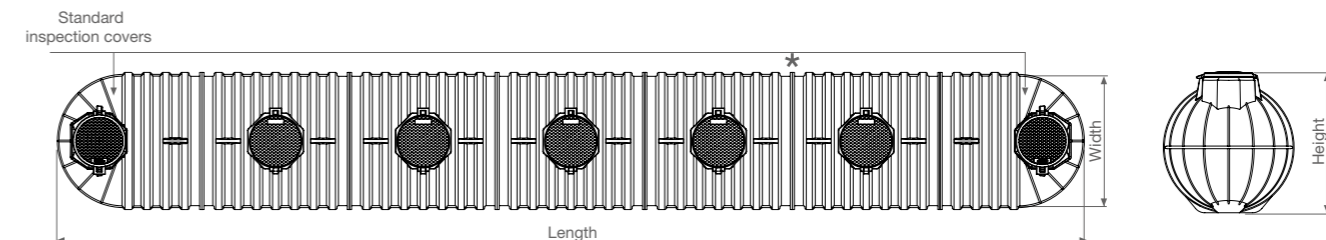

SPECIAL SHAPES

"U" SHAPE (ITU) INFINITANK

[FIND OUT MORE](#)

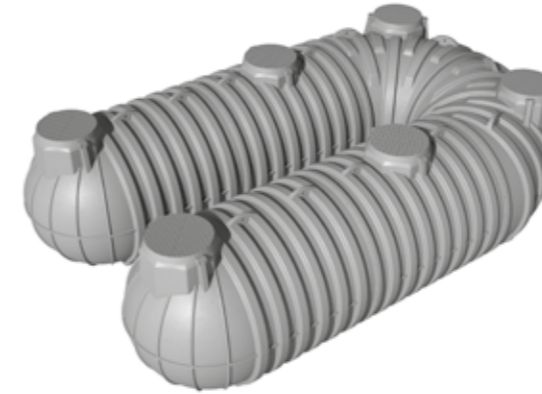

*ON-SITE WELDING

Where required, this will be carried out by specialist Rototec technicians and the cost will be calculated during the preparation of the offer.
N.B.: For larger sizes, please contact the Technical Office.
N.B.: The position of the asterisk is purely indicative.

Item	Useful vol. l	Length m	Width m	Height m	Basic modules				No. Standard inspection covers	No. Optional inspection covers	Extensions (optional)	On-site welding
					TS 7500	CN 7000	CR 7000	TE 8500				
ITU30000 000	30450	5.23	4.85	2.2	2	-	2	-	2	2	PP77	1

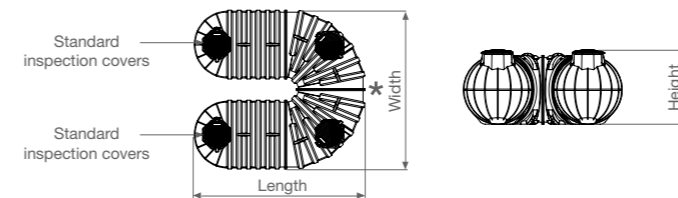

Item	Useful vol. l	Length m	Width m	Height m	Basic modules				No. Standard inspection covers	No. Optional inspection covers	Extensions (optional)	On-site welding
					TS 7500	CN 7000	CR 7000	TE 8500				
ITU45000 110	45150	7.40	4.85	2.2	2	2	2	-	2	4	PP77	1

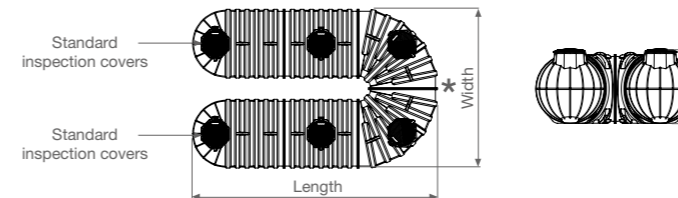

Item	Useful vol. l	Length m	Width m	Height m	Basic modules				No. Standard inspection covers	No. Optional inspection covers	Extensions (optional)	On-site welding
					TS 7500	CN 7000	CR 7000	TE 8500				
ITU60000 220	59850	9.75	4.85	2.2	2	4	2	-	2	6	PP77	1

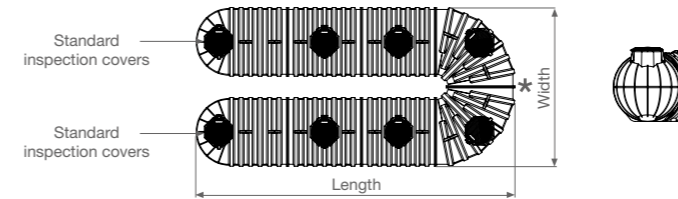

Item	Useful vol. l	Length m	Width m	Height m	Basic modules				No. Standard inspection covers	No. Optional inspection covers	Extensions (optional)	On-site welding
					TS 7500	CN 7000	CR 7000	TE 8500				
ITU75000 330	74550	11.85	4.85	2.2	2	6	2	-	2	8	PP77	1

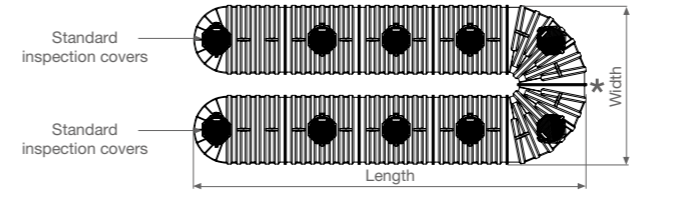

SEWAGE



WATER



UNDERGROUND INSTALLATION



CANOTTO (ITC) INFINITANK

FIND OUT MORE



***ON-SITE WELDING**

Where required, this will be carried out by specialist Rototec technicians and the cost will be calculated during the preparation of the offer.

N.B.: For larger sizes, please contact the Technical Office.
N.B.: The position of the asterisk is purely indicative.

Item	Useful vol. l	Length m	Width m	Height m	Basic modules				No. Standard inspection covers	No. Optional inspection covers	Extensions (optional)	On-site welding
					TS 7500	CN 7000	CR 7000	TE 8500				
ITC30000 00	29400	4.85	4.85	2.2	-	-	4	-	2	2	PP77	1

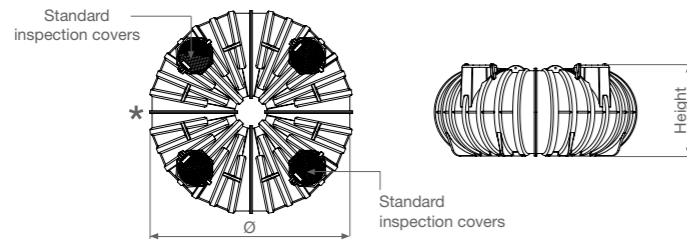

Item	Useful vol. l	Length m	Width m	Height m	Basic modules				No. Standard inspection covers	No. Optional inspection covers	Extensions (optional)	On-site welding
					TS 7500	CN 7000	CR 7000	TE 8500				
ITC45000 01	44100	7.36	4.85	2.2	-	2	4	-	2	4	PP77	1

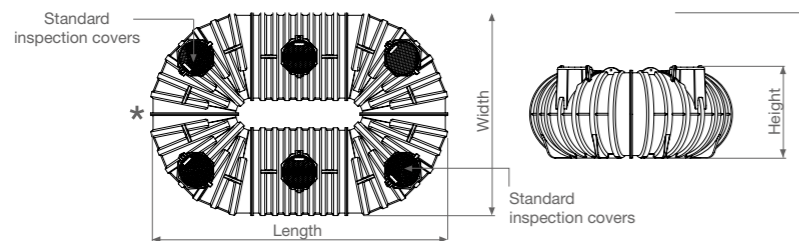

Item	Useful vol. l	Length m	Width m	Height m	Basic modules				No. Standard inspection covers	No. Optional inspection covers	Extensions (optional)	On-site welding
					TS 7500	CN 7000	CR 7000	TE 8500				
ITC60000 02	58800	9.62	4.85	2.2	-	4	4	-	2	6	PP77	1

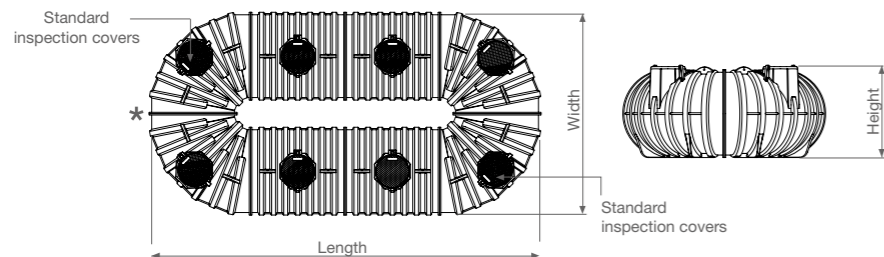

Item	Useful vol. l	Length m	Width m	Height m	Basic modules				No. Standard inspection covers	No. Optional inspection covers	Extensions (optional)	On-site welding
					TS 7500	CN 7000	CR 7000	TE 8500				
ITC75000 03	73500	11.88	4.85	2.2	-	6	4	-	2	8	PP77	1

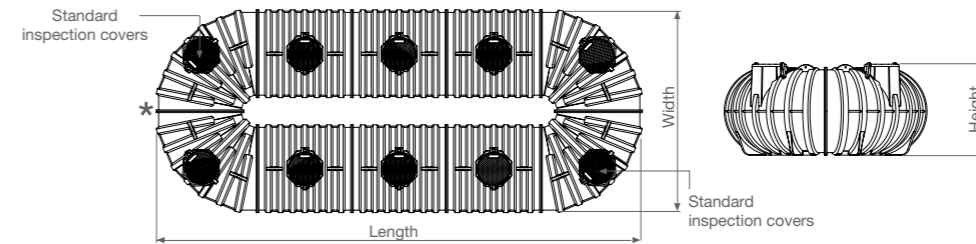

Item	Useful vol. l	Length m	Width m	Height m	Basic modules				No. Standard inspection covers	No. Optional inspection covers	Extensions (optional)	On-site welding
					TS 7500	CN 7000	CR 7000	TE 8500				
ITC90000 04	88200	14.14	4.85	2.2	-	8	4	-	2	10	PP77	2

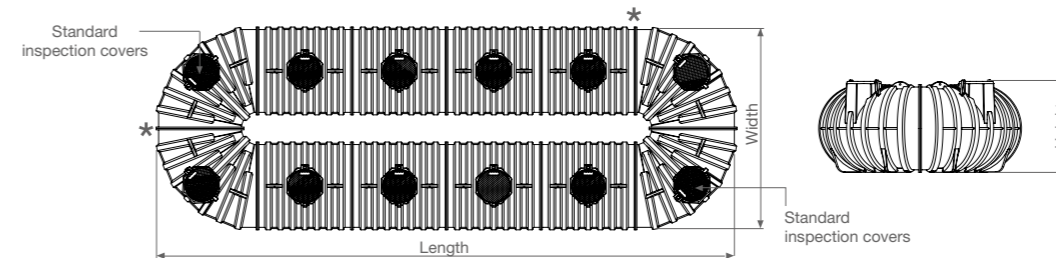

Item	Useful vol. l	Length m	Width m	Height m	Basic modules				No. Standard inspection covers	No. Optional inspection covers	Extensions (optional)	On-site welding
					TS 7500	CN 7000	CR 7000	TE 8500				
ITC100000 05	102900	16.40	4.85	2.2	-	10	4	-	2	12	PP77	3

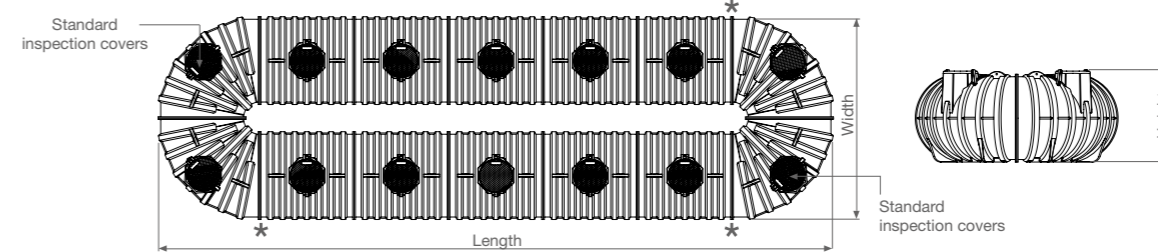

Item	Useful vol. l	Length m	Width m	Height m	Basic modules				No. Standard inspection covers	No. Optional inspection covers	Extensions (optional)	On-site welding
					TS 7500	CN 7000	CR 7000	TE 8500				
ITC120000 06	117600	18.66	4.85	2.2	-	12	4	-	2	14	PP77	3

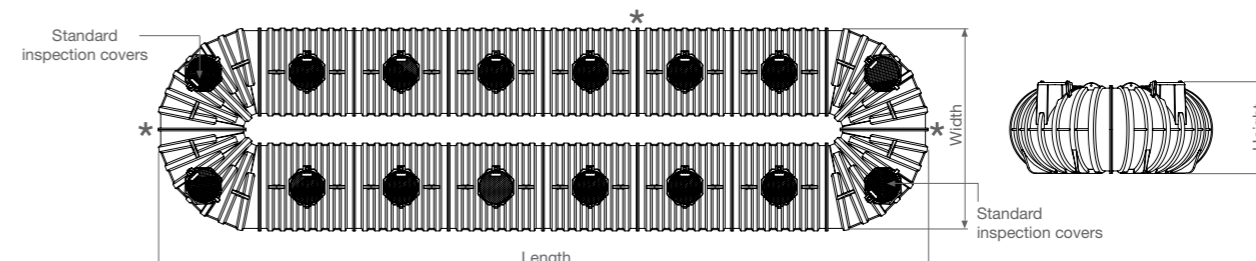

SEWAGE



WATER



UNDERGROUND INSTALLATION



REINFORCED CANOTTO (ITCR) INFINITANK

[FIND OUT MORE](#)



***ON-SITE WELDING**

Where required, this will be carried out by specialist Rototec technicians and the cost will be calculated during the preparation of the offer.
 N.B.: For larger sizes, please contact the Technical Office.
 N.B.: The position of the asterisk is purely indicative.

Item	Useful Vol. l	Length m	Width m	Height m	Basic modules				No. Standard inspection covers	No. Optional inspection covers	Extensions (optional)	On-site welding
					TS 7500	CN 7000	CR 7000	TE 8500				
ITCR75000 1110	76650	11.67	4.85	2.2	-	4	4	2	2	6	PP77	1

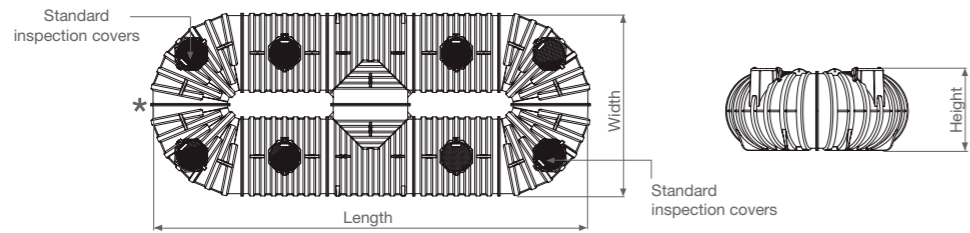

Item	Useful Vol. l	Length m	Width m	Height m	Basic modules				No. Standard inspection covers	No. Optional inspection covers	Extensions (optional)	On-site welding
					TS 7500	CN 7000	CR 7000	TE 8500				
ITCR100000 1111	98700	11.67	7.11	2.2	-	7	4	2	2	6	PP77	4

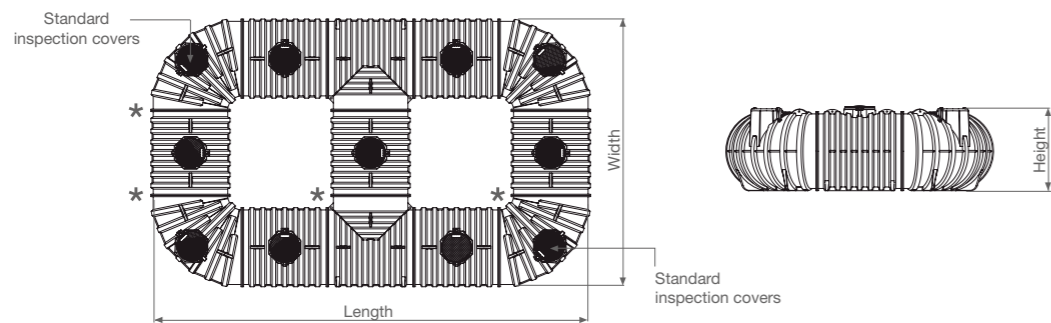

Item	Useful Vol. l	Length m	Width m	Height m	Basic modules				No. Standard inspection covers	No. Optional inspection covers	Extensions (optional)	On-site welding
					TS 7500	CN 7000	CR 7000	TE 8500				
ITCR110000 21110	109200	16.44	4.85	2.2	-	6	4	4	2	8	PP77	3

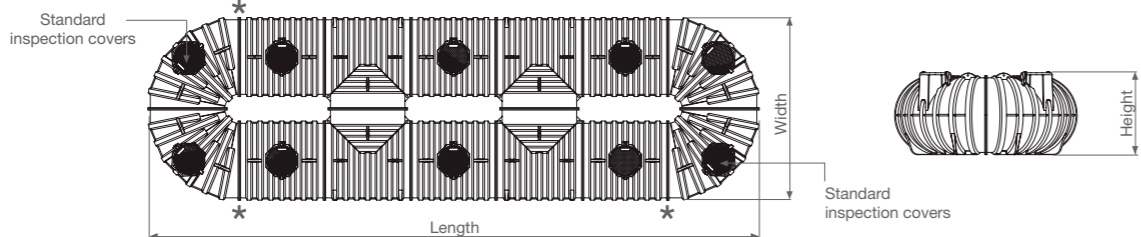

Item	Useful Vol. l	Length m	Width m	Height m	Basic modules				No. Standard inspection covers	No. Optional inspection covers	Extensions (optional)	On-site welding
					TS 7500	CN 7000	CR 7000	TE 8500				
ITCR140000 21111	138600	16.44	7.11	2.2	-	10	4	4	2	12	PP77	5

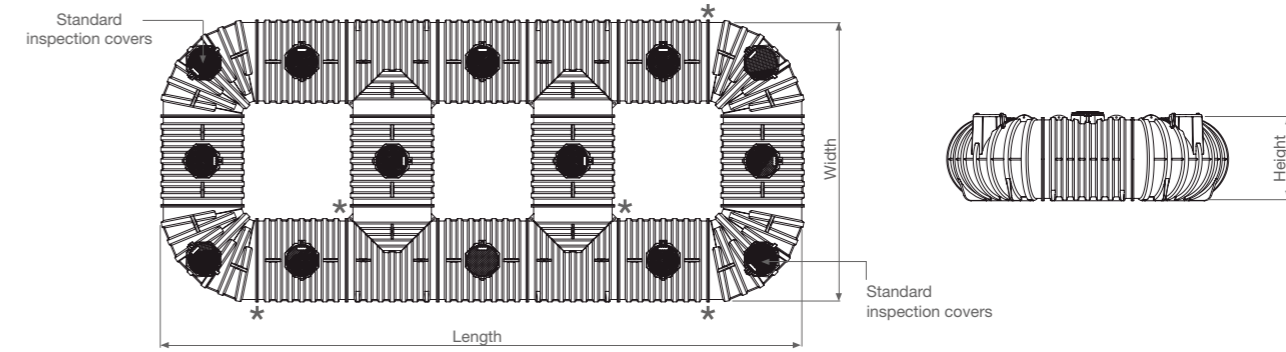

Item	Useful Vol. l	Length m	Width m	Height m	Basic modules				No. Standard inspection covers	No. Optional inspection covers	Extensions (optional)	On-site welding
					TS 7500	CN 7000	CR 7000	TE 8500				
ITCR140000 311110	141750	20.80	4.85	2.2	-	8	4	6	2	10	PP77	3

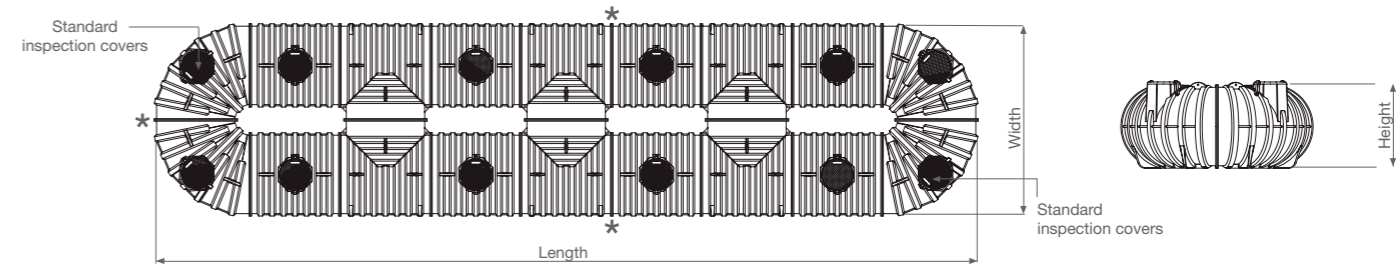

Item	Useful Vol. l	Length m	Width m	Height m	Basic modules				No. Standard inspection covers	No. Optional inspection covers	Extensions (optional)	On-site welding
					TS 7500	CN 7000	CR 7000	TE 8500				
ITCR180000 311111	178500	20.80	7.11	2.2	-	13	4	6	2	15	PP77	8

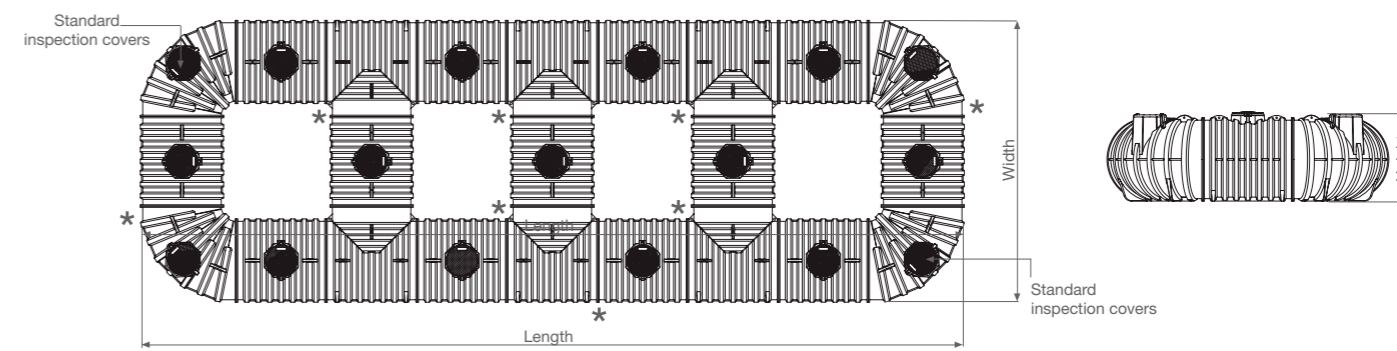

SEWAGE



WATER



UNDERGROUND INSTALLATION



SERPENTINA (ITSR) INFINITANK

[FIND OUT MORE](#)

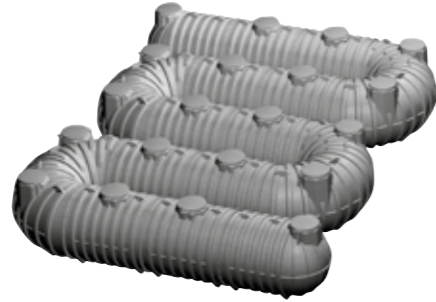

***ON-SITE WELDING**

Where required, this will be carried out by specialist Rototec technicians and the cost will be calculated during the preparation of the offer.
 N.B.: For larger sizes, please contact the Technical Office.
 N.B.: The position of the asterisk is purely indicative.

Item	Useful vol. l	Length m	Width m	Height m	Basic modules				No. Standard inspection covers	No. Optional inspection covers	Extensions (optional)	On-site welding
					TS 7500	CN 7000	CR 7000	TE 8500				
ITSR45000 200000	45150	5.22	7.60	2.2	2	-	4	-	2	4	PP77	2

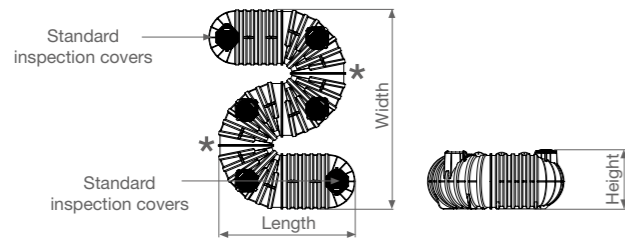

Item	Useful vol. l	Length m	Width m	Height m	Basic modules				No. Standard inspection covers	No. Optional inspection covers	Extensions (optional)	On-site welding
					TS 7500	CN 7000	CR 7000	TE 8500				
ITSR50000 200100	52500	7.11	7.60	2.2	2	1	4	-	2	5	PP77	2

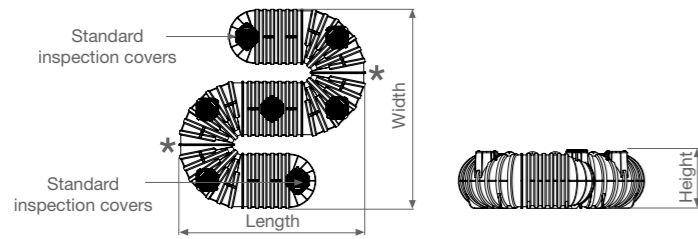

Item	Useful vol. l	Length m	Width m	Height m	Basic modules				No. Standard inspection covers	No. Optional inspection covers	Extensions (optional)	On-site welding
					TS 7500	CN 7000	CR 7000	TE 8500				
ITSR60000 210001	59850	10.10	7.60	2.2	2	2	4	-	2	6	PP77	2

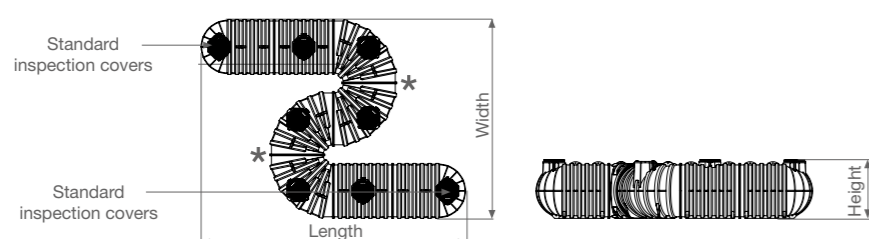

Item	Useful vol. l	Length m	Width m	Height m	Basic modules				No. Standard inspection covers	No. Optional inspection covers	Extensions (optional)	On-site welding
					TS 7500	CN 7000	CR 7000	TE 8500				
ITSR65000 210101	67200	7.84	7.60	2.2	2	3	4	-	2	7	PP77	2

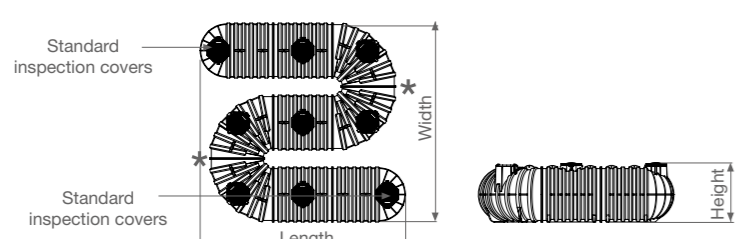

Item	Useful vol. l	Length m	Width m	Height m	Basic modules				No. Standard inspection covers	No. Optional inspection covers	Extensions (optional)	On-site welding
					TS 7500	CN 7000	CR 7000	TE 8500				
ITSR90000 31010101	89250	7.48	10.35	2.2	2	4	6	-	2	10	PP77	3

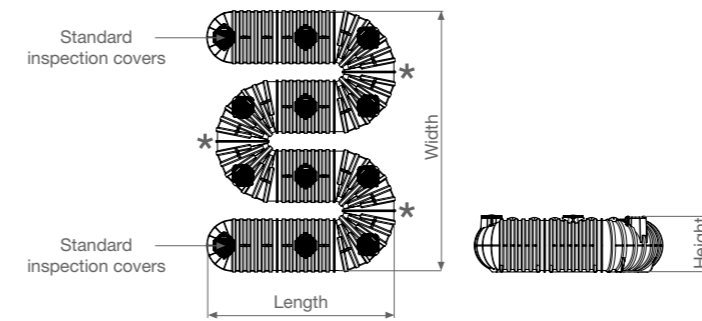

Item	Useful vol. l	Length m	Width m	Height m	Basic modules				No. Standard inspection covers	No. Optional inspection covers	Extensions (optional)	On-site welding
					TS 7500	CN 7000	CR 7000	TE 8500				
ITSR90000 220202	89250	10.10	7.60	2.2	2	6	4	-	2	10	PP77	2

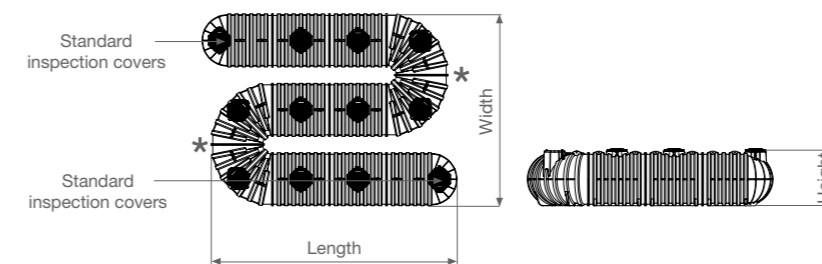

Item	Useful vol. l	Length m	Width m	Height m	Basic modules				No. Standard inspection covers	No. Optional inspection covers	Extensions (optional)	On-site welding
					TS 7500	CN 7000	CR 7000	TE 8500				
ITSR100000 230203	103950	15.20	7.60	2.2	2	8	4	-	2	12	PP77	2

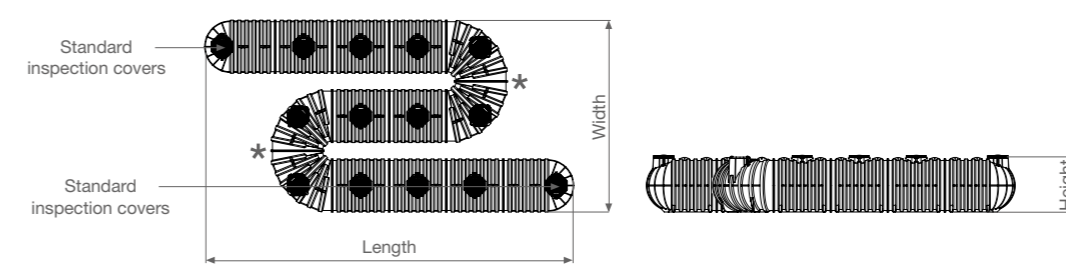

Item	Useful vol. l	Length m	Width m	Height m	Basic modules				No. Standard inspection covers	No. Optional inspection covers	Extensions (optional)	On-site welding
					TS 7500	CN 7000	CR 7000	TE 8500				
ITSR110000 230303	111300	12.36	7.60	2.2	2	9	4	-	2	13	PP77	2

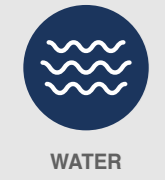
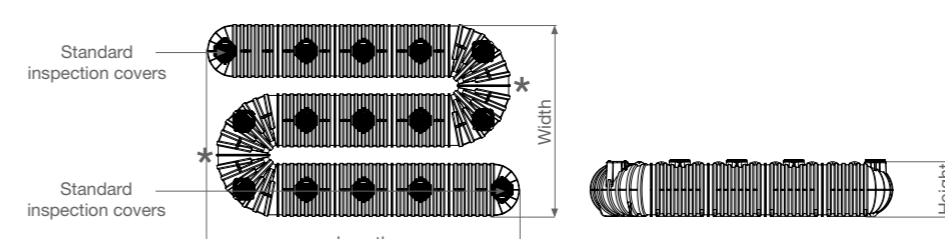

RAINWATER HARVESTING AND RE-USE SYSTEMS

Rototec offers a full range of rainwater harvesting and re-use systems, suitable for any type of use: from simple irrigation of green areas (gardens, flower beds, etc...) to domestic re-use (toilet flushing, washing cars and floors). According to the type of use, our range comprises the following harvesting and re-use systems.

SYSTEM	USE	SUPPLY	
<p>SIR IRRIGATION STATION</p>	<p>IRRIGATION OF GARDENS AND GREEN AREAS</p>	<ul style="list-style-type: none"> • UNDERGROUND TANK • INLET PIPE WITH STILLING PIPE AND OVERFLOW PIPE • SUBMERSIBLE PUMP • PRESSURE SWITCH 	
<p>HABITA IRRIGATION STATION</p>	<p>IRRIGATION OF GARDENS AND GREEN AREAS FILLING TOILET CISTERNS WASHING OUTDOOR SURFACES</p>	<ul style="list-style-type: none"> • UNDERGROUND TANK • INLET PIPE WITH STILLING PIPE AND OVERFLOW PIPE • SUBMERSIBLE PUMP • PROBE KIT + AUTOMATIC CONTROL PANEL + TOP-UP SOLENOID VALVE 	
<p>HABITA PRESS MODULE</p>	<p>IRRIGATION OF GARDENS AND GREEN AREAS FILLING TOILET CISTERNS WASHING OUTDOOR SURFACES WITH EXISTING UNDERGROUND STORAGE TANK ALREADY PRESENT</p>	<ul style="list-style-type: none"> • SELF-PRIMING PUMP • PROBE KIT + AUTOMATIC CONTROL PANEL + TOP-UP SOLENOID VALVE 	
<p>REINTEGRA MODULE</p>	<p>IRRIGATION OF GARDENS AND GREEN AREAS FILLING TOILET CISTERNS WASHING OUTDOOR SURFACES COMPLETE WITH STORAGE TANK AND DELIVERY PUMP</p>	<ul style="list-style-type: none"> • PROBE KIT + AUTOMATIC CONTROL PANEL + TOP-UP SOLENOID VALVE 	



SEWAGE



WATER



UNDERGROUND INSTALLATION



IRRIGATION STATIONS

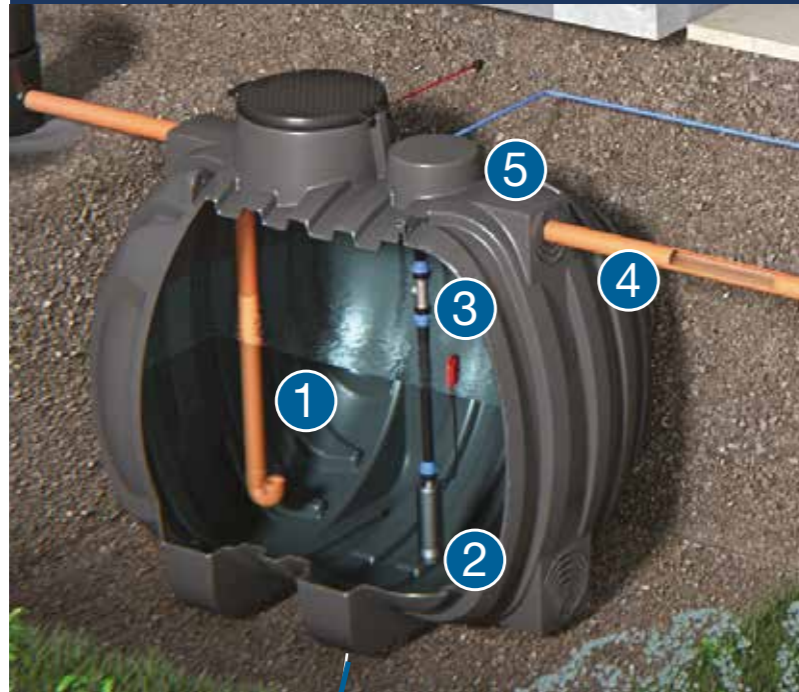

SIR

[FIND OUT MORE](#)

- 1 PVC INLET STILLING PIPE
- 2 SUBMERSIBLE PUMP
- 3 CLAPET TYPE VALVE
- 4 PVC OVERFLOW PIPE
- 5 PP PUMP OUTLET
Pressure switch included.



SPECIFICATIONS

TECHNICAL CHARACTERISTICS

SIR irrigation stations consist of both smooth and corrugated underground tanks. They are fitted with a PVC inlet stilling pipe and overflow pipe, PP (polypropylene) outlet pipe and connectors, submersible electric pump, polyethylene (PE) delivery pipe, clapet type check valve, pump lift rope and electronic control pressure switch.

USE

Rainwater harvesting and re-use for irrigation purposes, feeding automatic (telescopic irrigators, sprinklers, sprays, etc...) or manual systems (taps, fountains,...).

OPERATION

The system allows storage and delivery of between 1000 and 40000 litres of water (larger volumes on request). Rainwater run-off from roofs (or other exposed surfaces) enters the storage tank through the inlet pipe, after flowing through a filtering system (recommended). When the tank is full, any excess water is sent to the main drainage system through the overflow pipe. A submersible electric pump is installed in the tank. An electronic control pressure switch controls the pressure, allowing the stored water to be used.

SIR IRRIGATION STATIONS

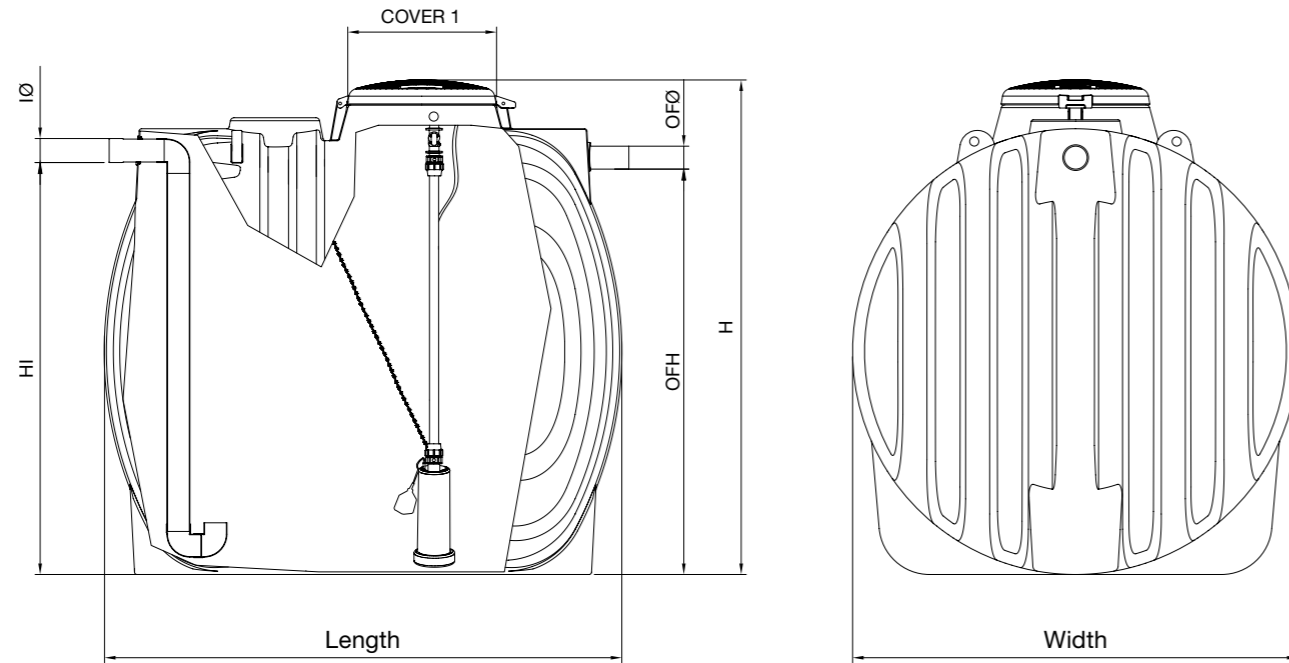

MODULAR SIR IRRIGATION STATIONS

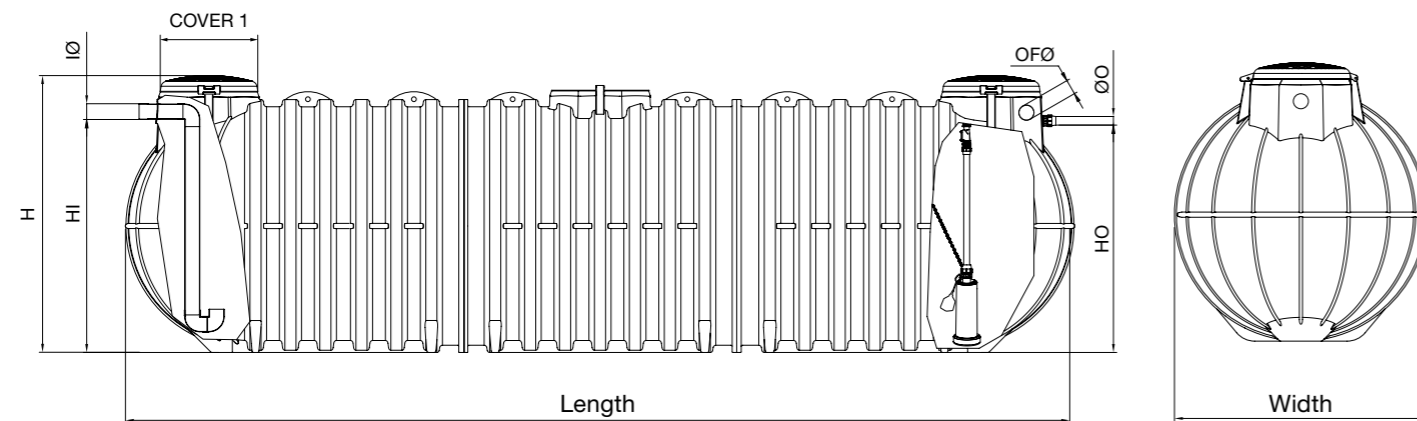

Item	Mod.	Capacity l	Length cm	Width cm	Ø cm	H cm	HO cm	HI cm	I Ø mm	Overflow Ø mm	Top-up Ø mm	Ø O mm	Cover Ø cm	Cover	Extension (optional)	Pump
SIRP11075		1000	-	-	120	105	95	76	100	100	50	50	30	CC300	PP35	PI40/08M
SIRP12075		2000	-	-	150	133	117	98	100	100	50	50	40	CC400	PP45	PI40/08M
SIR3075		3000	209	150	-	172	160	138	125	125	50	50	63	TAP800	PP77	PI40/08M
SIR3015		3000	209	150	63	172	160	138	125	125	50	50	63	TAP800	PP77	PI80/15M
SIRP13075		3000	-	-	171	165	147	138	125	125	50	50	63	TAP800	PP77	PI40/08M
SIRP13015		3000	-	-	171	165	147	138	125	125	50	50	63	TAP800	PP77	PI80/15M
SIR3575		3000	249	241	-	123	96	94	125	125	50	50	63	TAP800	PP77	PI40/08M
SIR3515		3000	249	241	-	123	96	94	125	125	50	50	63	TAP800	PP77	PI80/15M
SIRP14075		4000	-	-	171	215	197	188	125	125	50	50	63	TAP800	PP77	PI40/08M
SIRP14015		4000	-	-	171	215	197	188	125	125	50	50	63	TAP800	PP77	PI80/15M
SIR5075		5000	242	192	-	210	194	173	125	125	50	50	63	TAP800	PP77	PI40/08M
SIR5015		5000	242	192	-	210	194	173	125	125	50	50	63	TAP800	PP77	PI80/15M
SIR5375		5000	365	241	-	123	96	94	125	125	50	50	63	TAP800	PP77	PI40/08M
SIR5315		5000	365	241	-	123	96	94	125	125	50	50	63	TAP800	PP77	PI40/08M
new SIR6575		6000	397	241	-	123	96	94	125	125	50	50	63	TAP800	PP77	PI80/15M
new SIR6515		6000	397	241	-	123	96	94	125	125	50	50	63	TAP800	PP77	PI80/15M
SIR8075		8000	266	255	-	236	-	201	125	125	50	50	63	TAP800	PP77	PI40/08M
SIR8015		8000	266	255	-	236	-	201	125	125	50	50	63	TAP800	PP77	PI80/15M
SIRP18075		8000	-	-	227	275	254	246	125	125	50	50	63	TAP800	PP77	PI40/08M
SIRP18015		8000	-	-	227	275	254	246	125	125	50	50	63	TAP800	PP77	PI80/15M
new SIR8375		8000	513	241	-	123	96	94	125	125	50	50	63	TAP800	PP77	PI40/08M
new SIR8315		8000	513	241	-	123	96	94	125	125	50	50	63	TAP800	PP77	PI40/08M
SIR10075		10000	278	243	-	266	247	223	125	125	50	50	63	TAP800	PP77	PI40/08M
SIR10015		10000	278	243	-	266	247	223	125	125	50	50	63	TAP800	PP77	PI80/15M
SIRP110075		10000	-	-	227	300	280	271	125	125	50	50	63	TAP800	PP77	PI40/08M
SIRP110015		10000	-	-	227	300	280	271	125	125	50	50	63	TAP800	PP77	PI80/15M

Ø= diameter; H= height; Ø I/O= inlet/outlet pipe diameter; HI= inlet pipe height; HO= outlet pipe height.

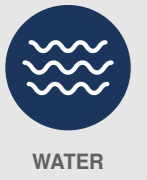

GREASE SEPARATORS
 IMHOFF BIOLOGICAL TANKS
 ABOVE-GROUND TANKS
 BIOLOGICAL SEPTIC TANKS
 ACTIVATED SLUDGE PLANT
 ABOVE-GROUND MODULAR FIRE-FIGHTING TANKS
 TRICKLE FILTERS
 SECONDARY TREATMENT PLANT
 UNDERGROUND TANKS
 DEPURBLOK
 DEPURU
 RAINWATER HARVESTING AND RE-USE SYSTEMS
 OIL DISPOSAL UNIT
 STORMWATER MANAGEMENT
 CAR WASH PLANTS
 CHAMBERS
 LIFT STATIONS
 CHAMBERS
 TECHNICAL SECTION
 PORTABLE TOILETS
 NON-STANDARD SOLUTIONS
 UNDERGROUND INSTALLATION
 ACCESSORIES

SIR IRRIGATION STATIONS

SUBMERSIBLE ELECTRIC PUMPS

SUBMERSIBLE PUMP FOR 5" WELLS

MATERIAL

Outer shell, motor cover, seal holder disk, filter and fastening ring in AISI 304; impeller, diffuser and spacer in PPE+PS reinforced with fibreglass; shaft in AISI 431; upper mechanical seal (motor side) in carbon/ceramic/NBR and lower seal (pump side) in SiC/carbon/NBR.

Electric pump with double mechanical seal surrounding an oil chamber. 2-pole self-ventilated asynchronous motor cooled by the fluid transported, insulation class F and protection level IP68.

FUNCTION Movement of clean water from wells, cisterns and rainwater collection tanks; pressurisation of domestic systems; small-scale irrigation; carwashes; pressure increases in general.

USE AND MAINTENANCE Under normal operating conditions, the electric pump does not require any maintenance operations. The only recommendation is that proper operation be checked periodically, in particular checking for any abnormal noise and vibration that may arise and checking any loss of mechanical seal.

ITEM
PI 40/08 M
PI 80/15 M



Pump model	Power		A1-A	µF	DNM inches	H mm	Weight kg	Flow rate		Head m
	HP	kW						l/min	m³/h	
PI 40/08M	0.8	0.6	4.3	16	1" ¼	513	14.6	20	1.2	43.3
								80	4.8	13.4
PI 80/15M	1.5	1.1	7.5	31.5	1" ¼	564	17.7	30	1.8	57
								120	7.2	19

Pump model	Max. immersion Depth m	Max grit concentration g/m³	Max. No. Start-ups No./h	Max. water T °C
PI 40/08M	20	2.5	20	40
PI 80/15M	20	2.5	20	40

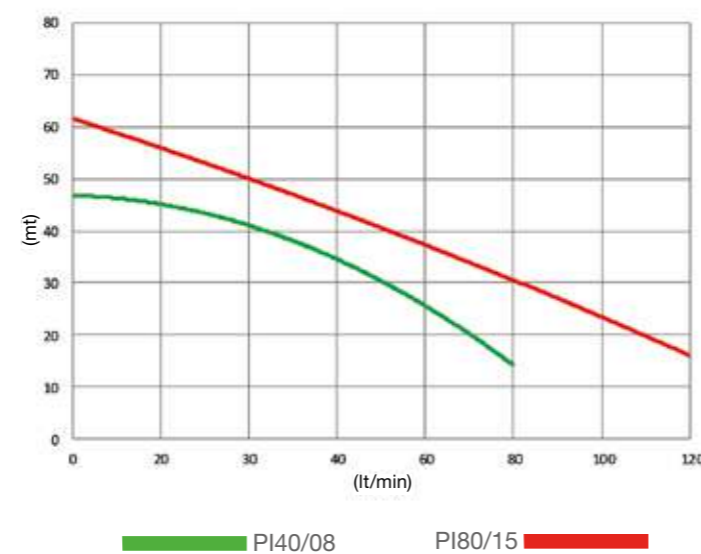
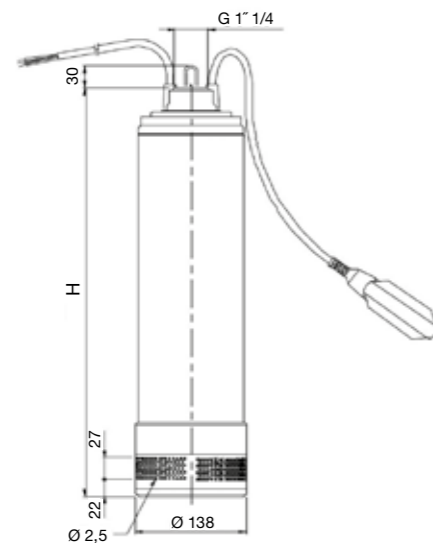

SIR IRRIGATION STATIONS

ACCESSORIES

PRESSURE REGULATOR (supplied)

Application Automatic electronic pressure-flow switch designed to control the operation of electric pumps.

Function It commands automatic starting and stopping of the pump when a tap or a valve connected to the system is opened or closed. When the pump is started, it remains in operation for as long as any one of the users stays open, delivering the required flow rate to the system. If there is no water at the suction end of the pump, the pump itself will stop automatically.

Construction characteristics Non return valve incorporated. Adjustable start-up pressure. Operation indicators and RESET button. Maximum water temperature 65°C. Protection level IP65.



Item	Power supply voltage V	Frequency Hz	Max. current intensity A	Start-up pressure bar	Max. working pressure bar	Max. fluid temperature	Protection level	Connections	Restart	Weight kg
PRESSCMF	115/230V	50-60	8A	2.2	10	+65°C	IP65	Threaded 1"	Fixed	0.6

ELECTRIC PUMP CONTROL PANEL WITH PRESSURE SWITCH (optional)

Function Electronic panel to command and protect a single phase user equipped with a pressure switch.

Installation If the panel with the pressure switch is installed outside and not protected against atmospheric agents, it should be housed in an appropriate casing or cabinet with protection level IP55.

Construction characteristics

- Power supply 1 ~ 50/60Hz 230V±10%
- Low voltage inputs and command circuits;
- Normally open input for start-up command;
- Level control relay for 3 unipolar probes or float switches;
- Button pad to select automatic, manual (momentary), Off/Reset;
- Dip-switch for Filling/Emptying probe operation;
- Adjustable probe sensitivity;
- Green mains electricity present LED;
- Green automatic operation On LED;
- Green motor On LED;
- Red level alarm LED;
- Red motor in overload alarm LED;
- Electronic adjustable motor overload control;

- Auxiliaries and motor protected by fuses;
- Alarm output (com-no-nc resistive load);
- Main switch with door interlock;
- Box in ABS, IP55;
- Room temperature: -5/+40 °C;
- Relative humidity 50% at 40 °C (without condensation).

Pressure switch characteristics

- Pressure switch built in compliance with EN60947-4/-5;
- Working room temperature: from -40 to +65 °C;
- Protection IP30;
- Electrical connection: inlet with 6 to 14 mm cable;
- Max. pressure: 17 bar.



Item	Pump power		Current A	Size			Weight kg
	kW	HP		Height mm	Length mm	Depth (mm)	
QCSIRPRESS1	0.37-2.2	0.5-3	16	320	240	190	1.5

FILTER CARTRIDGES (optional)

Material Transparent SAN bowl, filled polypropylene head, brass threaded inserts.

Application Filtration system to be installed downstream of a rainwater harvesting and re-use plant.

Function Single cartridge filtration to eliminate sediment and other physical impurities. Double cartridge filtration to eliminate chlorine and reduce odours.

Item	No. cartridges	Filtration type	Micron	Cartridge width mm	Cartridge height mm	Inlet/outlet diameter mm
FCR9SB	1	Polyester mesh	150	133	307	1"
FCR9SBCA	2	Polyester mesh + compressed extruded carbon	150 + 5/10	133	307	1"



HABITA IRRIGATION STATIONS

SPECIFICATIONS

[FIND OUT MORE](#)

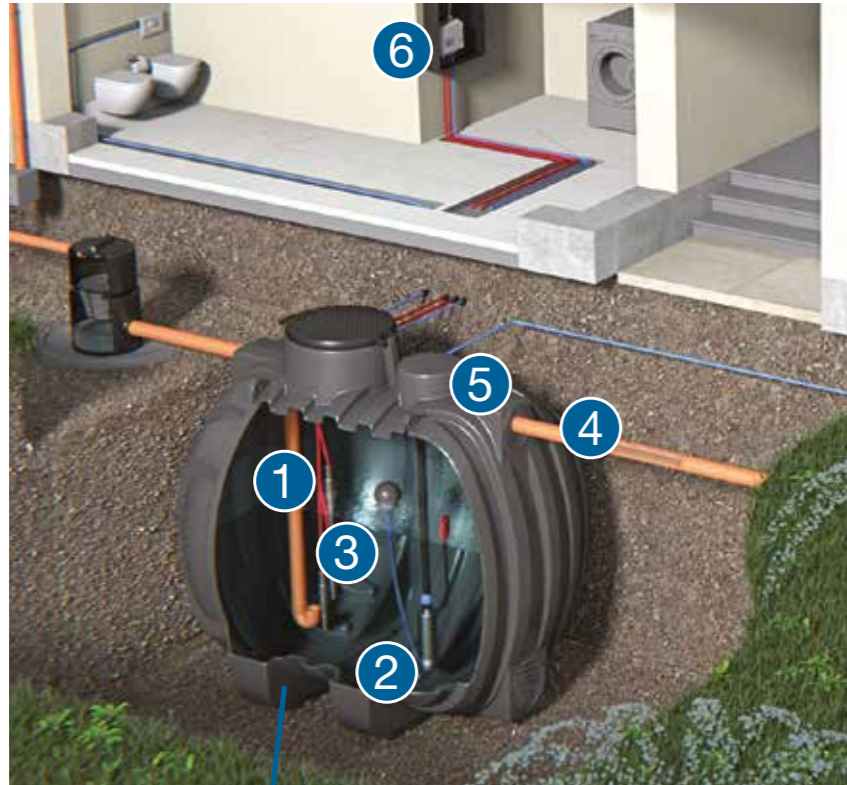

- 1 PVC INLET STILLING PIPE
- 2 SUBMERSIBLE PUMP WITH SUBMERGED SUCTION INLET
- 3 WATER LEVEL CONTROL PROBE
- 4 PVC OVERFLOW PIPE
- 5 PP PUMP OUTLET
- 6 EXTERNAL MODULE WITH ELECTRONIC PRESSURE-FLOW SWITCH FOR LEVEL MANAGEMENT AND TOP-UP SOLENOID VALVE

TECHNICAL CHARACTERISTICS HABITA irrigation stations consist of corrugated underground tanks. They are fitted with a PVC inlet stilling pipe and overflow pipe, polypropylene (PP) outlet pipe and connectors, submersible electric pump with steel rapid extraction system, level probes, negative head suction inlet with float and filter, polyethylene (PE) delivery pipe, electric control panel, 3-way solenoid valve and isolating system to top-up with mains water in the absence of rainfall.

USE Rainwater harvesting and re-use for irrigation purposes, feeding automatic (telescopic irrigators, sprinklers, sprays, etc...) or manual systems (taps, fountains,...) and for domestic use (filling toilet cisterns, washing cars and outdoor surfaces).

OPERATION The system allows storage and delivery of between 3000 and 40000 litres of water (larger volumes on request). Rainwater run-off from roofs (or other exposed surfaces) enters the storage tank through the inlet pipe, after flowing through a filtering system (recommended). When the tank is full, any excess water is sent to the main drainage system through the overflow pipe. A submersible electric pump is installed in the tank with level control probes which, through a control unit and a 3-way solenoid valve, allow the tank to be replenished directly from the mains water supply. By using this engineering solution, the customer will never have problems caused by a shortage of water in his storage tanks. Furthermore, with the pump installed inside the tank, there is no noise, no space taken up by other smaller tanks, no unsightly boxes installed near the storage tanks, etc...

COMPONENT CHARACTERISTICS ELECTRIC PUMPS

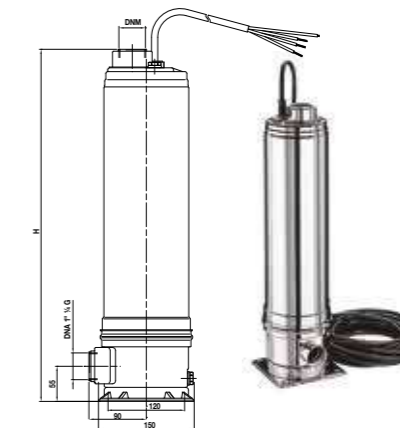
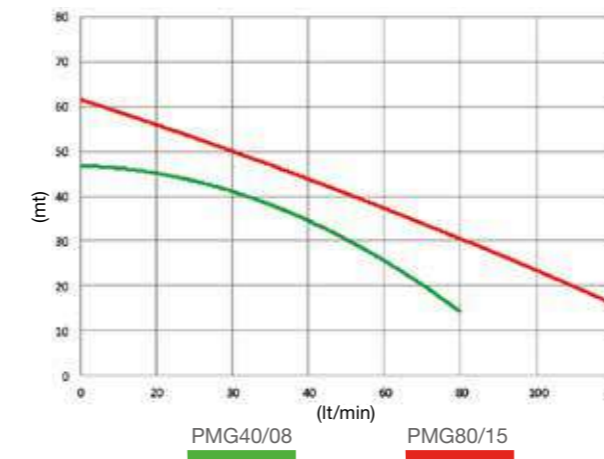

Pump model	Power		A1-A	µF	DNM inches	H mm	Weight kg	Flow rate		Head m
	HP	kW						l/min	m³/h	
PMG40/08	0.8	0.6	4.3	16	1" ¼	513	14.6	20	1.2	43.3
								80	4.8	13.4
PMG80/15	1.5	1.1	7.5	31.5	1" ¼	564	17.7	30	1.8	57
								120	7.2	19

MANAGEMENT MODULE (fig. A)

Item
MSIRHMT

SUCTION KIT (fig. B)

Item
N150114

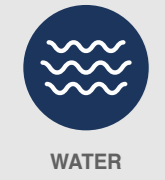
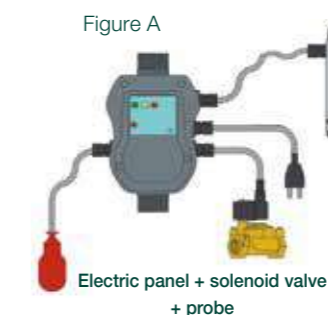

HABITA IRRIGATION STATIONS

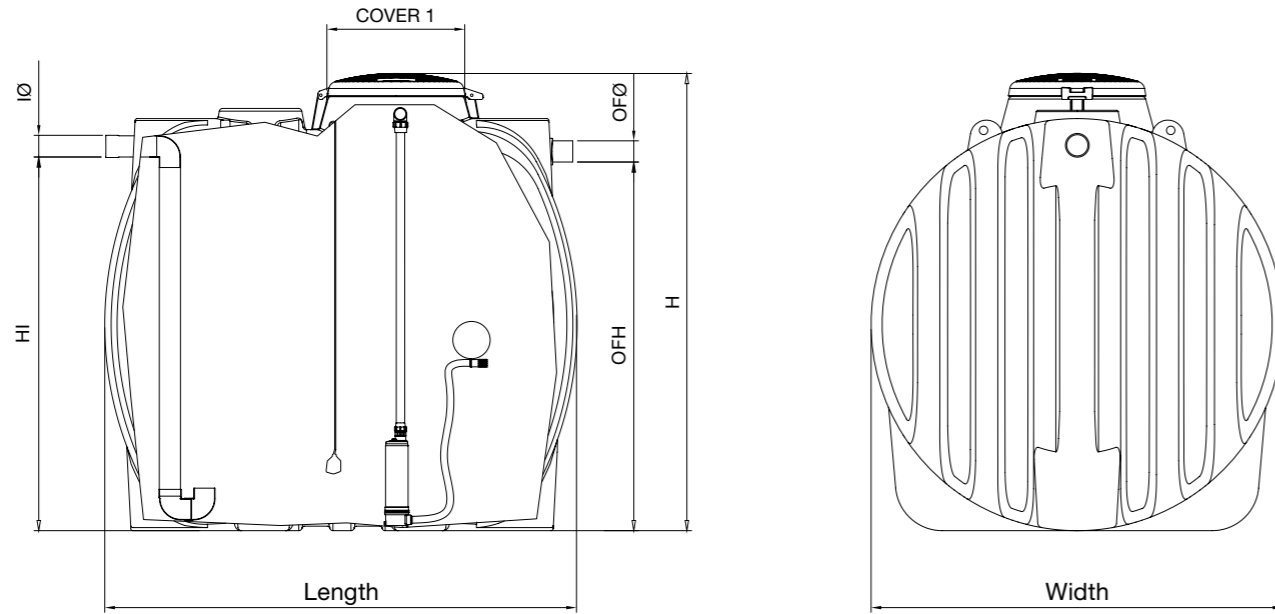

MODULAR HABITA IRRIGATION STATIONS

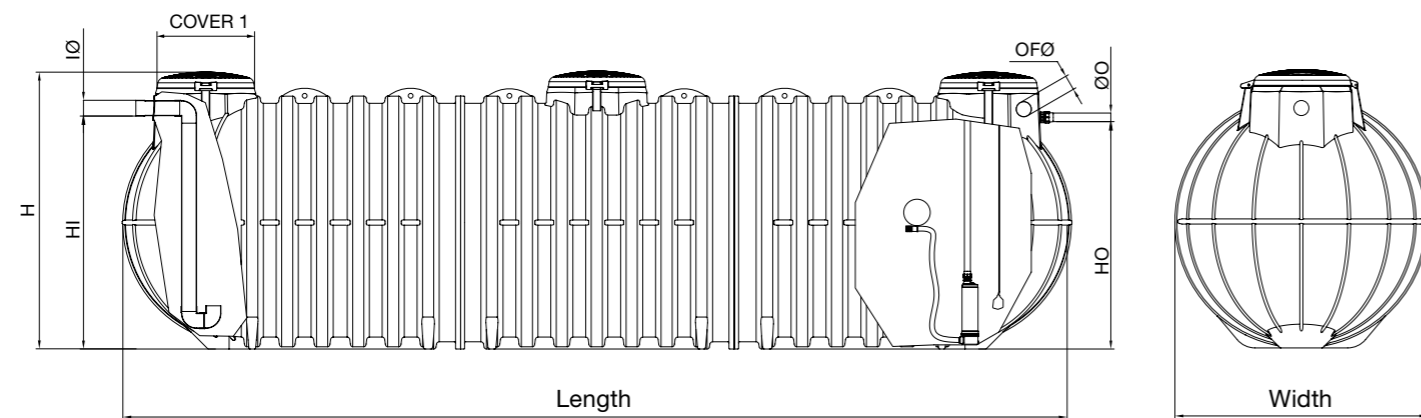

Item	Mod.	Capacity l	Length cm	Width cm	H cm	HO cm	HI cm	IØ mm	Overflow Ø mm	Ø O mm	Top-up Ø mm	Cover Ø cm	Cover	Extension (optional)	Pump
SIRP1100H		1000	-	-	105	95	76	100	100	50	50	30	CC300	PP35	PMG40/08
SIRP12100H		2000	-	-	133	117	98	100	100	50	50	40	CC400	PP45	PMG40/08
SIR3100H		3000	209	150	172	160	139	125	125	50	50	63	TAP800	PP77	PMG40/08
SIR3120H		3000	209	150	172	160	139	125	125	50	50	63	TAP800	PP77	PMG80/15
SIR3510H		3000	249	241	123	96	94	125	125	50	50	63	TAP800	PP77	PMG40/08
SIR3512H		3000	249	241	123	96	94	125	125	50	50	63	TAP800	PP77	PMG80/15
SIRPI3100H		3000	-	-	165	147	138	125	125	50	50	63	TAP800	PP77	PMG40/08
SIRPI3120H		3000	-	-	165	147	138	125	125	50	50	63	TAP800	PP77	PMG80/15
SIRPI4100H		4000	-	-	215	197	188	125	125	50	50	63	TAP800	PP77	PMG40/08
SIRPI4120H		4000	-	-	215	197	188	125	125	50	50	63	TAP800	PP77	PMG80/15
SIR5100H		5000	242	192	210	194	173	125	125	50	50	63	TAP800	PP77	PMG40/08
SIR5120H		5000	242	192	210	194	173	125	125	50	50	63	TAP800	PP77	PMG80/15
SIR5310H		5000	365	241	123	96	94	125	125	50	50	63	TAP800	PP77	PMG40/08
SIR5312H		5000	365	241	123	96	94	125	125	50	50	63	TAP800	PP77	PMG80/15
new SIR6510H		6000	397	241	123	96	94	125	125	50	50	63	TAP800	PP77	PMG40/08
new SIR6512H		6000	397	241	123	96	94	125	125	50	50	63	TAP800	PP77	PMG80/15
SIR8100H		8000	266	225	236	225	201	125	125	50	50	63	TAP800	PP77	PMG40/08
SIR8120H		8000	266	225	236	225	201	125	125	50	50	63	TAP800	PP77	PMG80/15
new SIR8310H		8000	513	241	123	96	94	125	125	50	50	63	TAP800	PP77	PMG40/08
new SIR8312H		8000	513	241	123	96	94	125	125	50	50	63	TAP800	PP77	PMG80/15
SIR10100H		10000	278	243	266	247	223	125	125	50	50	63	TAP800	PP77	PMG40/08
SIR10120H		10000	278	243	266	247	223	125	125	50	50	63	TAP800	PP77	PMG80/15

H= height; Ø I/O= inlet/outlet pipe diameter; HI= inlet pipe height; HO= outlet pipe height.

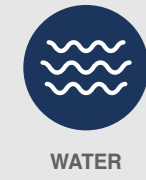
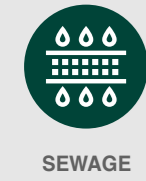

HABITA PRESS MODULE

SPECIFICATIONS

[FIND OUT MORE](#)

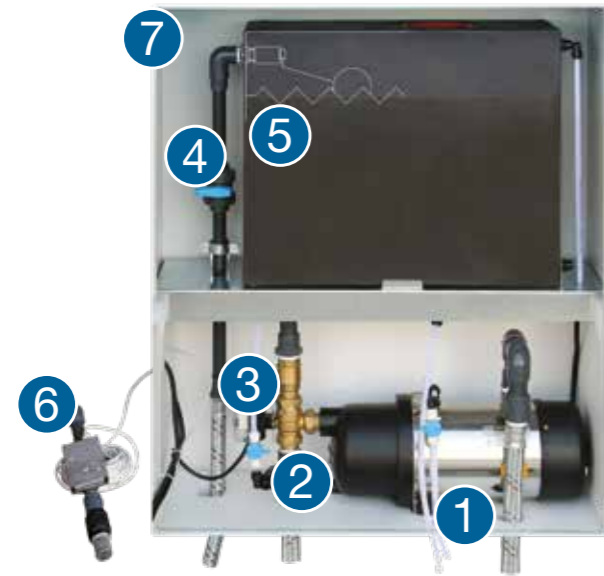

- 1 SELF-PRIMING ELECTRIC PUMP
- 2 3-WAY SOLENOID VALVE
- 3 PUMP CONTROL PRESSURE SWITCH
- 4 MAINS WATER INLET PIPE
- 5 RESERVE TANK
- 6 PROBE KIT WITH CHECK VALVE, TO BE FITTED IN THE EXISTING TANK
- 7 SOUNDPROOF SAFETY CABINET

TECHNICAL CHARACTERISTICS

Pre-assembled control unit containing a self-priming electric pump, a command/control unit, a motorised solenoid valve, an auxiliary tank for mains water and all the fittings required for correct operation of the system. The supply also includes a suction kit to install in the collection tank, complete with probes, check valve and stainless steel filter.

USE

Suction and delivery under pressure of the rainwater in the storage tanks. Ideal for feeding automatic irrigation systems (telescopic irrigators, sprinklers, sprays, etc.) or manual systems (taps, fountains,...), or for washing outdoor surfaces, car washing, filling toilet cisterns,...

OPERATION

In the HABITA PRESS system the pump is not submersible, but is external and housed in a soundproofed cabinet together with the intermediate tank holding mains water. The system also has an isolating system kit that prevents any risk of contact between the mains water and the rainwater. In order to prevent the pump from entering an alarm state due to lack of water in the underground tank, the minimum rainwater level control is entrusted to a special system of probes, giving consent to the control unit to open the motorised valves to feed the tank. This control system is installed on a calibrated tube, complete with bottom valve, to be lowered into the underground storage tank in order to guarantee the standard working level and, as a consequence, minimum control over the amount of water to add to the tank.

ELECTRIC PUMP CHARACTERISTICS

Item	Power		Amps A	Volt V	Flow rate l/ min	Head t
	kW	HP				
XMHP120	0.90	1.2	6.3	230	0	49
					60	8

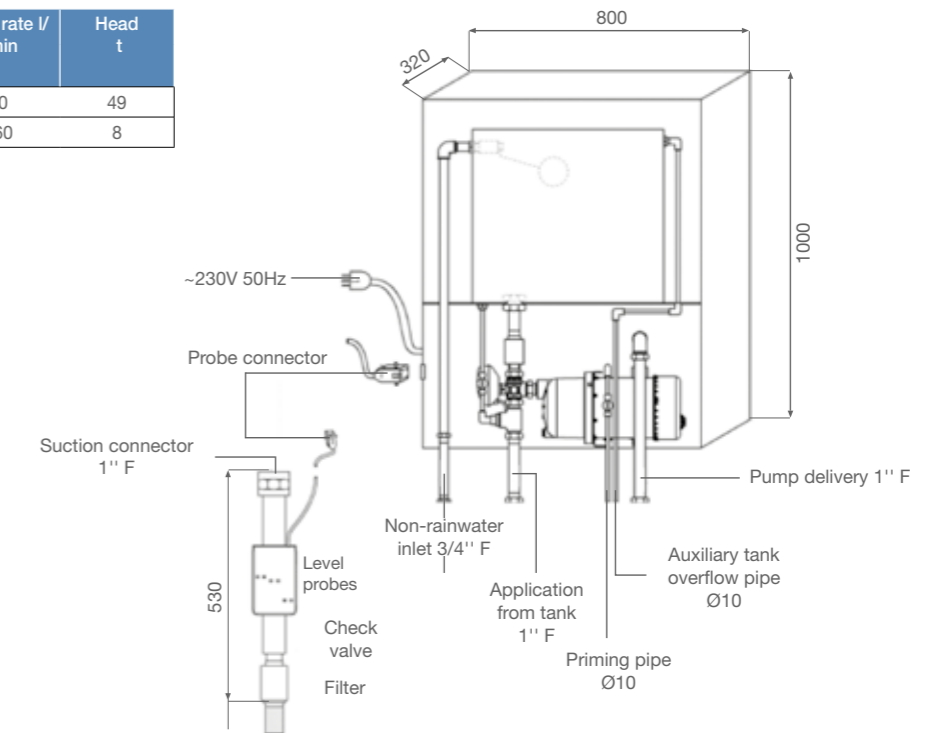

SEWAGE



WATER



UNDERGROUND INSTALLATION



REINTEGRA MODULE

SPECIFICATIONS

[FIND OUT MORE](#)



- 1 ELECTRIC PANEL With LEDs indicating alarm level, rainwater usage level and top-up in operation
- 2 PROBE KIT TO BE FITTED IN THE EXISTING TANK
- 3 SOLENOID VALVE
- 4 POWER SUPPLY CABLE

TECHNICAL CHARACTERISTICS

Control panel with protection grade IP40 complete with leds indicating alarm level, rainwater usage level, top-up in operation and plant fed; normally closed solenoid valve in brass with ½ ” female connections; stainless steel level probes; 2 m power cable with schuko plug; 2 m solenoid valve cable; 20 m probes cable.

USE

Module to be combined with rainwater recovery tanks in which a delivery system is already installed, to allow control of the minimum level of accumulated rainwater and manage topping-up from the mains supply.

OPERATION

During periods of low rainfall, the rainwater recovery tank empties and it becomes necessary to top-up the water in order to use the services that benefit from the harvested rainwater. This operation is carried out by the REINTEGRA module, simply connecting the solenoid valve to the mains water supply and installing probes inside the storage tank.

The system electronics registers the status of the tank through led indicators, providing information on whether the level is sufficient, whether it will soon require topping-up, or whether topping-up is already in progress.

TECHNICAL CHARACTERISTICS

Item	Power supply V	Frequency Hz	Probes No.	Height mm	Length mm	Depth mm
XMR	230	50	3	240	190	90

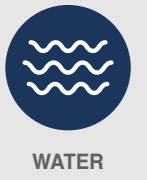

CHAMBERS

FIND OUT MORE

LEAF FILTER CHAMBER



Item	Ø mm	H mm	HI mm	HO mm	Ø I/O mm	Cover Ø mm	Cover
FAPI	420	780	560	60	110	300	CC 300
FAPI D125	420	780	560	60	125	300	CC 300
FAPI D160	420	780	510	60	160	300	CC 300

Material Chamber in linear high density polyethylene (LHDPE), complete with PVC inlet and outlet pipes, internal filter basket in polypropylene with stainless steel handle for easy removal.

Application Filters out the coarse materials present in the collected rainwater (stones, leaves, tile residues, debris, etc...).

COMPACT SELF-CLEANING LEAF FILTER CHAMBER

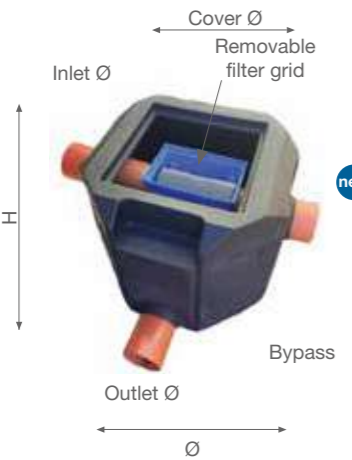

Item	Ø mm	H mm	Ø I/O mm	HI mm	HO mm	HBP mm	Filter grid mm	Inspection mm	Cover Ø mm	Cover
new FAPI150CP	660	550	125	330	60	300	1	400	40	CP 40G

Material Chamber in linear polyethylene (LLDPE), complete with PVC inlet, outlet and bypass pipes and internal self-cleaning filter basket. To be installed upstream of the storage tank. The chamber is characterised by the presence of an inlet pipe, an outlet pipe and a bypass, all in PVC.

Application The water arriving through the inlet pipe passes through a fine mesh filter and is then carried to the storage tank via the outlet pipe. The impurities that accumulate in the filter are washed away by the incoming water and discharged through a bypass pipe. Consequently, in addition to its self-cleaning characteristics, the filter also has minimum height difference between the inlet and outlet pipes.

COMPACT LEAF FILTER



Item	H mm	Length mm	Width mm	ΔHI-HO mm	I/O/OF Ø mm	Filter mesh mm
FAPI CP	340	420	230	0	125	1

Application This is a compact filter that filters out the coarse materials present in the collected rainwater (stones, leaves, debris, etc...). For installation on the inlet pipe inside a rainwater storage tank. The filter solves filtration problems caused by a very shallow gradient and/or very little available space. The presence of an overflow ensures that the filter is cleaned automatically by the inlet flow.

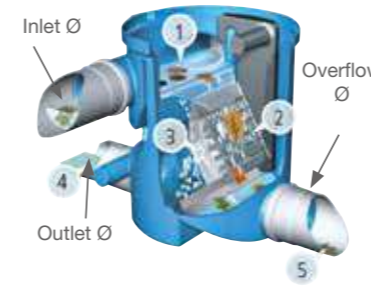

SELF-CLEANING LEAF FILTER CHAMBER

Item	Ø mm	H mm	Ø I/O mm	OF Ø mm	Filter mesh mm	Filtered water volume %/d	Max. flow rate supported l/s	Max. draw-off surface m²
FAPIV1	404	451	100	125	0.25x0.65	5.43	11.6	350

Application Very efficiently filters out the coarse materials present in the collected rainwater (stones, leaves, tile residues, debris, etc...). The considerable slope of the filter body enables 2 filtration phases to be carried out:
 - rough filtration of larger particles, with the residue being sent to the overflow;
 - further filtration of the separated water, with clean water being sent to the storage tank.



SELF-CLEANING LEAF FILTER CHAMBER

Item	Ø mm	H mm	Ø I/O mm	OF Ø mm	Filter mesh mm	Max. flow rate supported l/s	Max. draw-off surface m²
FAPIW	680	873	from 100 to 150	from 100 to 150	0.65	37	1250

Material One-piece polyethylene chamber, fitted with inlet, outlet and overflow, equipped internally with a self-cleaning stainless steel filtering and filtered water storage system.

Application Rainwater filter suitable for large roof areas. The 3P Twinfilter can be installed outside buildings in concrete chambers with a diameter of 1000 mm or buried directly in the ground. The filter is provided with an inspection manhole cover. Its 2-step cleaning process renders it highly efficient regardless of the flow rate. The continuous self-cleaning action is guaranteed by the steeply inclined filter cartridges, with the waste material being directed towards the overflow and outlet channel. The clean water is collected in a tank and then discharged to a storage tank.



BACKFLOW/ANTI-RAT CHAMBER

Item	Ø mm	H mm	Ø I/O mm	Cover Ø mm	Cover	Extension (optional)
PAR 50	430	430	125	300	CC 300	PP 35

Material One-piece chamber in linear high density polyethylene (LHDPE), complete with PVC inlet and outlet pipes and rubber watertight gasket, inspectable PVC backflow valve with stainless steel claret and locking lever.

Application When installed on a waste water drain pipe, the device stops any backflow from the main sewer and prevents the basement from being flooded. At the same time, the valve prevents animals (e.g. rats) from running up the pipe.

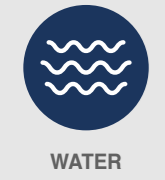



SEWAGE



WATER



UNDERGROUND
INSTALLATION



TECHNICAL SECTION

- p. 266 FITTING THE UNIONS
- p. 268 TABLE OF POLYETHYLENE STRENGTHS
- p. 270 CERTIFICATION
- p. 272 SPECIFICATION ITEMS

FITTING PIPE UNIONS ON THE TANKS

1. PREPARING THE HOLE

Use a hole saw to cut a hole with the same diameter as the external diameter of the union in the appropriate flat area of the tank. The hole must be made at the centre of the flat area at a height of approximately 10 cm from the bottom of the tank. A suitable wooden spacer will make this operation easier.



2. FITTING THE UNION

Place the inner washer on the union then insert the union in the hole from the inside of the tank. If the union is difficult to insert, hit it lightly with a rubber mallet. At this point, place the outer gasket on the union and then screw on the ring nut.



3. FIXING THE UNION

Screw the ring nut on the union. Carefully tighten the nut using a chain pipe wrench or similar. Finally, clean the inside of the tank and union, removing any fragments of polyethylene produced during the assembly phase.



SPECIAL OPERATIONS

On request, Rototec is able to carry out special machining operations on its tanks: diversions with smooth and corrugated PE pipes, flanged connectors, threaded brass or plastic diversions, ...



SEWAGE



WATER



UNDERGROUND
INSTALLATION



TABLE OF RESISTANCE OF THE TANKS TO SOME FLUIDS AND REAGENTS

R = Resistant / LR = Limited resistance / NR = No resistance

Product	23° 60°	Product	23° 60°	Product	23° 60°	Product	23° 60°
Acetic acid (10 %)	R R	Ammonia (100% gas)	R R	Ferrous sulphate (oso)	R R	Potassium sulphate (conc.)	R R
Acetic acid (50 %)	R LR	Ammonium carbonate	R R	Bisodium phosphate	R R	Potassium sulphate (conc.)	R R
Arsenic acid (all conc.)	R R	Ammonium chloride (Sat. sol.)	R R	Sodium phosphate (tri)	R R	Potassium sulphate (conc.)	R R
Ascorbic acid (10 %)	R R	Ammonium fluoride (Sat. sol.)	R R	Fructose	R R	Propylene dichloride (100%)	NR NR
Benzoic acid (all conc.)	R R	Ammonium hydrate (10 %)	R R	Furfural	NR NR	Propylenglycol	R R
Boric acid (all conc.)	R R	Ammonium hydrate (30 %)	R R	Automotive diesel fuel*	R R	Copper cyanide (sat.)	R R
Bromidic acid (50 %)	R R	Ammonium nitrate (Sat. sol.)	R R	Domestic diesel fuel*	R R	Copper chloride (sat.)	R R
Butyric acid (all conc.)	NR NR	Ammonium persulphate (Sat. sol.)	R R	Glycerine	R R	Copper fluoride (2 %)	R R
Carbonic acid	R R	Ammonium sulphate (Sat. sol.)	R R	Triethylene glycol	R R	Copper nitrate (sat.)	R R
Chlorosulphonic acid (100%)	NR NR	Air	R R	Hydroquinone	R R	Cider	R R
Citric acid (sat.)	R R	Carbon dioxide	R R	Ethylene glycol	R R	Resorcinol	R R
Diglycolic acid	R R	Barium carbonate (Sat. sol.)	R R	Hydrogen	R R	Sodium acetate	R R
Fluoboric acid	R R	Barium chloride (Sat. sol.)	R R	Ink	R R	Sodium benzoate (35%)	R R
Fluorhydric acid (40%)	R R	Barium hydrate	R R	Iodine (sol. in KI)	LR NR	Sodium bicarbonate	R R
Fluorhydric acid (60 %)	R R	Barium sulphate (Sat. sol.)	R R	Milk	R R	Sodium bichromate	R R
Fluosilicic acid	R R	Barium sulphide (Sat. sol.)	R R	Photograph developer liquids	R R	Sodium bisulphate	R R
Fluosilicic acid (30 %)	R R	Benzene	NR NR	Lye (10 %)	R R	Sodium bisulphite	R R
Formic acid (all conc.)	R R	Petrol	NR NR	Yeast	R R	Sodium borate	R R
Gallic acid	R R	Beer	R R	Magnesium carbonate	R R	Sodium bromide	R R
Glycolic acid	R R	Bismuth carbonate (Sat. sol.)	R R	Magnesium chloride	R R	Sodium carbonate	R R
Hydrochloric acid (all conc.)	R R	Silver nitrate (sol.)	R R	Aromatic hydrocarbons	NR NR	Diazo salts	R R
Hydrochloric acid (dry gas)	R R	Aniline	NR NR	Glucose	R R	Brine	R R
Hydrocyanic acid	R R	Acetic anhydride	NR NR	Glycol	R R	Copper sulphate (sat.)	R R
Hypochlorous acid	R R	Borax	R R	Magnesium hydroxide	R R	Sodium cyanide	R R
Nitric acid (30%)	R R	Boron trifluoride	R R	Magnesium nitrate	R R	Sodium chlorate	R R
Nitric acid (50 %)	R LR	Bromine (liquid)	NR NR	Magnesium sulphate	R R	Sodium chloride	R R
Nitric acid (70 %)	R LR	Butandiol (100 %)	R R	Mercury	R R	Sodium ferrocyanide	R R
Nitric acid (95 %)	NR NR	Butandiol (10 %)	R R	Methylene chloride (100%)	LR NR	Sodium fluoride	R R
Oxalic acid	R R	Butandiol (50 %)	R R	Naphtha	LR NR	Sodium hydroxide (caustic soda)	R R
Salicylic acid	R R	Butylacetate	NR NR	Naphthalene	NR NR	Sodium hypochlorite	R R
Selenic acid	R R	Coffee	R R	Nickel chloride	R R	Sodium nitrate	R R
Sulfidic acid	R R	Calcium bisulphite	R R	Nickel nitrate	R R	Sodium sulphate	R R
Sulphuric acid (10%)	R R	Calcium chlorate (Sat. sol.)	R R	Nicotine (diluted)	R R	Sodium sulphite	R R
Sulphuric acid (50 %)	R R	Calcium chloride (Sat. sol.)	R R	Nitrobenzene	NR LR	Carbon disulphide	NR NR
Sulphuric acid (70 %)	R LR	Calcium hydrate (all conc.)	R R	n-Heptane	LR LR	Soap solutions (all conc.)	R R
Sulphuric acid (80%)	R NR	Calcium nitrate (50%)	R R	n-Octane	R R	Photographic solutions	R R
Sulphuric acid (96 %)	LR NR	Calcium oxide (Sat. sol.)	R R	Mineral oils	R LR	Silver plating solution	R R
Sulphuric acid (fuming)	NR NR	Calcium carbonate (Sat. sol.)	R R	Nickel sulphate	R R	Sodium sulphite	R R
Vinegar	R R	Amyl chloride	R R	Ferrous nitrate (ico)	R R	Potassium persulphate	R R

R = Resistant / LR = Limited resistance / NR = No resistance

Product	23° 60°	Product	23° 60°	Product	23° 60°	Product	23° 60°
Sulphuric acid (98 %)	LR NR	Calcium sulphate	R R	Camphor oil	LR NR	Cadmium plating solution	R R
Sulphurous acid	R R	Carbon tetrachloride	LR NR	Cotton seed oil	R R	Nickel plating solutions	R R
Stearic acid	R R	Liquid chlorine	NR NR	Corn oil	R R	Gold plating solutions	R R
Tannic acid	R R	Chlorine (100%) dry gas	LR NR	Castor oil (all conc.)	R R	Brass plating solutions	R R
Water	R R	Chlorobenzene	NR NR	Olive oil	R NR	Lead plating solutions	R R
Seawater	R R	Cola concentrates	R R	Perchloroethylene	NR NR	Tin plating solutions	R R
Nitromuriatic acid	NR NR	Dextrin	R R	Lead acetate	R R	Zinc plating solutions	R R
Turpentine	LR LR	Dextrose	R R	Lead nitrate	R R	Tin chloride (ico)	R R
Wetting agents	NR NR	Dextrose (sat. aqueous sol.)	R R	Pyridine	R R	Tin chloride (oso)	R R
Amyl alcohol	R R	Synthetic detergents	R R	Fruit pulp	R R	Tetrahydrofuran	LR NR
Butyl alcohol	R R	Dibutyl phthalate	LR LR	Potassium bicarbonate	R R	Titanium tetrachloride	NR NR
Coconut oil alcohol	RR R	Dicholoro ethane	NR NR	Potassium bromide	R R	Toluene	LR LR
Ethyl alcohol	R R	Dichlorobenzene (ortho and para)	NR NR	Potassium carbonate	R R	Trichloroethylene	NR NR
Ethyl alcohol (35 %)	R R	Diethyl chetone	LR LR	Potassium cyanide	R R	Urea (30 %)	R R
Furfural alcohol	LR NR	Diethylene glycol	R R	Potassium chlorate	R R	Vanilla	R R
Methyl alcohol (100%)	R R	Dimethylamine	NR NR	Potassium chloride	R R	Wines	R R
Propargylic alcohol	R R	Photographic emulsifiers	R R	Potassium chromate (40%)	R R	Whiskey	R R
Propylic alcohol	R R	Hexachlorobenzene	R R	Potassium dichromate (40%)	R R	Xylene	NR NR
Acetic aldehyde	LR NR	Hexanol (tertiary)	R R	Potassium hexacyanoferrate II	R R	Zinc bromide	R R
Alum (all types)	R R	Ethyl ether	NR NR	Potassium hexacyanoferrate III	R R	Zinc carbonate	R R
Aluminium chloride (all conc.)	R R	Ethyl acetate	LR NR	Potassium fluoride	R R	Zinc chloride	R R
Aluminium fluoride (all conc.)	R R	Ethyl benzene	NR NR	Potassium hydroxide (conc.)	R R	Zinc oxide	R R
Aluminium sulphate (all conc.)	R R	Ethyl chloride	NR NR	Potassium nitrate	R R	Zinc sulphate	R R
Starch (saturated solution)	R R	Ferrous chloride (ico)	R R	Potassium perchlorate (10%)	R R	Zinc stearate	R R
Amyl acetate	NR NR	Ferrous chloride (oso)	R R	Potassium permanganate (20%)	R R		

We herewith declare that our polyethylene tanks are suitable for storing diesel fuel, as reported in the above polyethylene compatibility table. The information reported in this table is purely indicative, in that the resistance of the products against chemical agents is also influenced by their form and by the conditions of use. It is well known that an increase in temperature always results in an increase in the aggressive nature of the substance stored in the tank. Consequently, for all the above fluids, if the working temperature is near to 70° C, prior to using the tank, the customer must always carry out a test using a sample of the material, in that in these cases, ROTOTEC S.p.A. is unable to offer precise guarantees or assume any responsibility. It is nevertheless advisable to contact our technical office beforehand.

For further information, contact our sales office: some of the mentioned agents may require special connections or gaskets.

NB: when using with liquids other than water, take into account the differences in specific weight.

* The tanks do not have Fire Service type-approval for containing diesel fuel

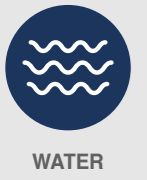



SEWAGE



WATER

UNDERGROUND
INSTALLATION

UNDERGROUND TANKS

TECHNICAL CHARACTERISTICS

Thanks to rotational moulding technology and the chemical-physical-mechanical characteristics of linear high density polyethylene (LLDPE), the underground tanks possess the ideal characteristics for the problem-free storage of large volumes of liquids. Polyethylene, in fact, is totally non-toxic and does not foster the growth of algae in fluids contained in the tanks, making them ideal for storing potable water and other liquid foodstuffs. Furthermore, linear polyethylene also supports sudden changes in temperature (from -20 to + 80 °C) and is inert in the presence of chemical substances in the soil. For these reasons, there are no material oxidation or corrosion problems that would prejudice the mechanical characteristics and impermeability of the tanks. These characteristics are also guaranteed by the fact that rotational moulding allows one-piece tanks to be produced, i.e. free of welds that could weaken parts of the tanks subjected to internal stresses. Furthermore, while possessing the same characteristics as other materials (cement, fibreglass, metal), tanks in polyethylene are much lighter, and as such transport, installation and maintenance are extremely simple and economical. Finally, polyethylene tanks can be bored when the need arises, for example when connecting tanks together, installing inlet/outlet pipes, overflows, etc.

ROTOTEC supplies three models of tanks for underground installation, which differ in shape, structure and capacity: the Cisterna model stores from 1000 to 10000 litres, the Panettone model has a capacity of from 3000 to 10000 litres, while the modular system (MINITANK and INFINITANK) can be used to create very large storage tanks, in theory of infinite size.

Each tank is equipped with one or more threaded or hinged inspection covers on which it is possible to install extensions when the top of the tank is below ground level. Finally, on request, the tanks can be equipped with the appropriate pumps for delivering the stored water at flow rates, pressures and heads needed for the various applications.

APPLICATIONS

The characteristics previously mentioned render the underground tanks ideal for:

- Storing potable water or other liquid foodstuffs;
- Creating large volumes of stored water for firefighting, washing or irrigation plants;
- Creating lift stations for pumping water to higher levels;
- Collecting and storing rainwater for eventual re-use for irrigation, washing hardstandings, filling toilet cisterns, etc....

WARNINGS

In order to ensure that the characteristics of the underground tanks remain unaltered over time, that the stored substances do not deteriorate and that the ROTOTEC guarantee remains valid (25 years against full-depth corrosion) the following instructions must be carefully followed:

- The underground tanks must not, under any circumstances, be installed above ground;
- Prior to installation, carefully check the integrity of the tanks and the tightness of the gaskets;
- Do not install the tanks near to sources of heat;
- The tanks must be positioned on a flat stable surface. Special care must be taken in areas characterised by ground instability. When positioning, always adhere strictly to the installation methods provided (see Underground installation);
- When installing the tanks, to prevent the formation of algae, make sure that no light can filter in;
- Use flexible piping when connecting to the water system in order to prevent stresses during tank filling and emptying;
- Do not leave the tank without its cover for any length of time;

In the case of rainwater storage, it is advisable to install a filter chamber upstream of the tank, to prevent a build-up of grit, silt, leaves, etc. inside the tank;

- For storing fluids not expressly indicated in this catalogue, contact our technical office
- Products in PE manufactured using rotational moulding can have the following tolerances: +/- 3% on dimensions; +/- 5% on capacity

USE AND MAINTENANCE

- When carrying out maintenance operations and cleaning of the underground tank and any components installed inside it, always comply with the requirements indicated in Legislative Decree 81/2008 (Consolidation Act on Safety at Work) for temporary or mobile work sites;
- keep the area around the tank free of any material that could obstruct or impede the maintenance work;
- always work in pairs when carrying out tank inspection and cleaning operations, and wear suitable safety equipment (safety harness, lines, gloves,...);
- check the tank every 6 months. If any sediment is found at the bottom of the tank, remove it and clean the tank thoroughly using a normal domestic detergent. If any foreign bodies are found, disinfect the tank thoroughly;
- check that any PVC inlet, outlet and overflow pipes, brass or plastic filling, emptying and draining connectors are not blocked by large solids that prevent the passage of the fluid in the tank. If any sediment is found, it must be removed;
- every 6 months check that the pipes, connectors and gaskets are watertight;
- periodically check that the vent serving the pump and installed on the tank is free. If it is blocked it must be cleaned.

ABOVE-GROUND TANKS

TECHNICAL CHARACTERISTICS

Thanks to rotational moulding technology and the chemical-physical-mechanical characteristics of linear high density polyethylene (LLDPE), the above-ground tanks possess the ideal characteristics for the problem-free storage of large volumes of liquids. Polyethylene, in fact, is totally non-toxic and does not foster the growth of algae in the fluids contained in the tanks, thus making the tanks ideal for storing potable water and other foodstuffs. Furthermore, linear polyethylene also supports sudden changes in temperature (from -20 to + 80 °C) and is inert in the presence of chemical and physical atmospheric agents. For these reasons, there are no material oxidation or corrosion problems that would prejudice the mechanical characteristics and impermeability of the tanks. These characteristics are also guaranteed by the fact that rotational moulding allows one-piece tanks to be produced, i.e. free of welds that could weaken parts of the tanks subjected to internal stresses. Furthermore, while possessing the same characteristics as other materials (cement, fibreglass, metal), tanks in polyethylene are much lighter, and as such transport, installation and maintenance are extremely simple and economic. Finally, polyethylene tanks can be bored when the need arises, for example when connecting tanks together, installing inlet/outlet pipes, overflows, etc. ROTOTEC supplies a wide range of tank models for above ground installation, with capacities ranging from 50 to 14300 litres. The various forms of the tanks are designed to create storage facilities even in locations where installation space is restricted (e.g. cellars, attics, stairwells...). Thanks to the flanged joints or brass/plastic pipe unions mounted on the appropriate flat areas, the various tanks can be connected together to obtain larger storage volumes. Each tank is equipped with a threaded or hinged inspection cover, and many models are fitted with inlet, outlet and drain holes. The standard colour of above-ground tanks is blue. Other colours are also available on request, such as Green, Black, Terracotta and Grey. Finally, on request, above-ground tanks can also be equipped with the appropriate pumps for delivering the stored water at the flow rates, pressures and heads needed for the various applications.

APPLICATIONS

The characteristics previously mentioned render the outdoor tanks ideal for:

- Storing potable water or other liquid foodstuffs in areas either outside or inside residential properties;
- Creating large volumes of stored water for firefighting, washing or irrigation plants;
- Creating lift stations for pumping water to higher levels;
- Collecting and storing rainwater for re-use in irrigation, washing.

WARNINGS

In order to ensure that the characteristics of the above-ground tanks remain unaltered over time, that the stored substances do not deteriorate and that the ROTOTEC guarantee remains valid (25 years against full-depth corrosion) the following instructions must be carefully followed:

- The above-ground tanks must not, under any circumstances, be installed underground;
- Prior to installation, carefully check the integrity of the tanks and the tightness of the gaskets;
- Do not install the tanks near to sources of heat;
- The tanks must be positioned on a flat, stable surface;
- When installing the tanks, to prevent the formation of algae, make sure that no light can filter in;
- Use flexible piping when connecting to the water system in order to prevent stresses during tank filling and emptying;
- Do not leave the tank without its cover for any length of time;
- In the case of rainwater storage, it is advisable to install a filter chamber upstream of the tank to prevent a build-up of grit, silt, leaves, etc. inside the tank;
- For storing fluids not expressly indicated in this catalogue (page 262), contact the technical office;
- Place the tanks in easily reachable locations and avoid constructing parts in brickwork that could interfere with replacement or maintenance operations;
- When installing a pump, internally or externally, fit a suitable sized vent on the tank to prevent the formation of a vacuum when the pump is running.
- Products in PE manufactured using rotational moulding can have the following tolerances: +/- 3% on dimensions; +/- 5% on capacity

USE AND MAINTENANCE

- When carrying out maintenance operations and cleaning of the tank and any components installed inside it, always comply with the requirements indicated in Legislative Decree 81/2008 (Consolidation Act on Safety at Work) for temporary or mobile work sites;
- keep the area around the tank free of any material that could obstruct or impede the maintenance work;
- always work in pairs when carrying out tank inspection and cleaning operations, and wear suitable safety equipment;
- check the tank every 6 months. If any sediment is found at the bottom of the tank, remove it and clean the tank thoroughly using a normal domestic detergent. If any foreign bodies are found, disinfect the tank thoroughly;
- check that any PVC inlet, outlet and overflow pipes or brass or plastic filling, emptying, draining connectors are not blocked by large solids that prevent the passage of the fluid in the tank. If any sediment is found, it must be removed;
- check every 6 months to ensure that pipes, connectors and gaskets are watertight;
- periodically check that the vent serving the pump and installed on the tank is free. If it is blocked it must be cleaned.



SEWAGE



WATER



UNDERGROUND
INSTALLATION



UNDERGROUND INSTALLATION

TECHNICAL SECTION

CHAMBERS

LIFT STATIONS

CHAMBERS

CAR WASH PLANTS

STORMWATER MANAGEMENT

DEPURO

DEPURBLOK

SECONDARY TREATMENT PLANT

TRICKLE FILTERS

ACTIVATED SLUDGE PLANT

BIOLOGICAL SEPTIC TANKS

NON-STANDARD SOLUTIONS

TECHNICAL SECTION

CHAMBERS

PORTABLE TOILETS

OIL DISPOSAL UNIT

RAINWATER HARVESTING AND RE-USE SYSTEMS

UNDERGROUND TANKS

CONSTRUCTION SITE EQUIPMENT

ACCESSORIES

ABOVE-GROUND MODULAR FIREFIGHTING TANKS

IMHOFF BIOLOGICAL TANKS

ABOVE-GROUND TANKS

UNDERGROUND INSTALLATION

GREASE SEPARATORS

UNDERGROUND INSTALLATION

WATCH THE VIDEO



SEWAGE



WATER



UNDERGROUND INSTALLATION



-  Corrugated tanks model Cisterna
-  Corrugated tanks model Canotto
-  Corrugated tanks model Panettone
-  Smooth tanks model Cisterna
-  Smooth tanks model Panettone
-  Modular tanks
-  Corrugated septic tanks
-  Corrugated septic tanks model Elipse
-  Reinforced septic tanks
-  Smooth septic tanks
-  Septic tanks with separation baffles

WARNINGS

- a) When carrying out any of the operations, comply with Legislative Decree 81/08 and subsequent amendments governing safety at temporary and mobile construction sites.
- b) On arrival of the goods, carefully check the material to make sure it corresponds to the order and the project data. Any defects and/or damage due to transport must be reported immediately. Contact the company directly by telephone, fax or e-mail.
- c) Check that the product is provided with all the standard documentation (technical data sheets, installation instructions, etc...). Inform the company of any missing items. A copy will be sent immediately.
- d) Make sure that the gaskets, pipes and all the various parts other than in polyethylene are suitable for the liquid to be contained.
- e) Avoid impacts and contact with sharp-edged objects that could compromise the integrity of the product.
- f) Only handle the tanks when they are completely empty using the lifting eyes (where provided). NEVER lift the tanks by the inlet or outlet pipes.
- g) For the choice of backfill material and compaction methods, refer to European Standards ENV 1046 and UNI EN 1610.
- h) During the installation works, mark the boundary of the working area with suitable warning signs.

PROHIBITIONS

- a) It is absolutely forbidden to install underground tanks above ground.
- b) It is absolutely prohibited to use the tanks for storing industrial waste or liquids containing chemical substances or mixtures that are not compatible with polyethylene (see compatibility table supplied by Rototec).
- c) Underground tanks are NOT suitable and must NOT be used for storing diesel fuel.



HANDLING

- a) On delivery, the goods must be unloaded from the truck using suitable means capable of lifting the weight. Please contact the Rototec offices for the weight of products.
- b) In the case of a closed truck unloading must take place from the side using a fork lift vehicle. The forks must be long enough to protrude at least 30 cm beyond the product. Take great care not to hit the product with the tip of the forks, to avoid damaging it (Fig.1).
- c) In the case of an open truck unloading may also take place from above using a crane or mechanical fork lift, using steel chains, cables or straps suitable for hooking to the lifting eye bolts present on the products or wrapping them around its external diameter (Fig.1-3)
- d) It is possible to use the same equipment described in the preceding points to move the material, always taking care not to hit the product or drag it along the ground, and never passing or standing under and in the vicinity of the loads being moved
- e) To prevent the load from becoming unbalanced, always place the chains, ropes or cables symmetrically, respecting the lifting angle which must NEVER be less than 45° (Fig. 3-4)
- f) All loading, unloading, lifting and movement operations must be carried out ALWAYS WITH THE PRODUCTS COMPLETELY EMPTY.
- g) During suspended movement the product can be kept still using one or more ropes, preventing it from turning around the connection point. In the same way it is possible to turn it, for example to lower it into the excavation or in general onto the installation point (Fig.2)

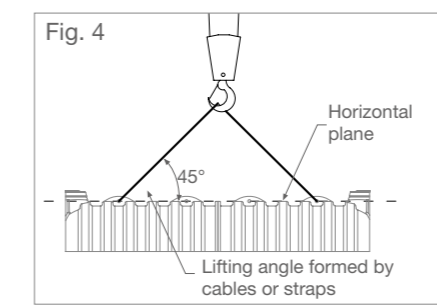
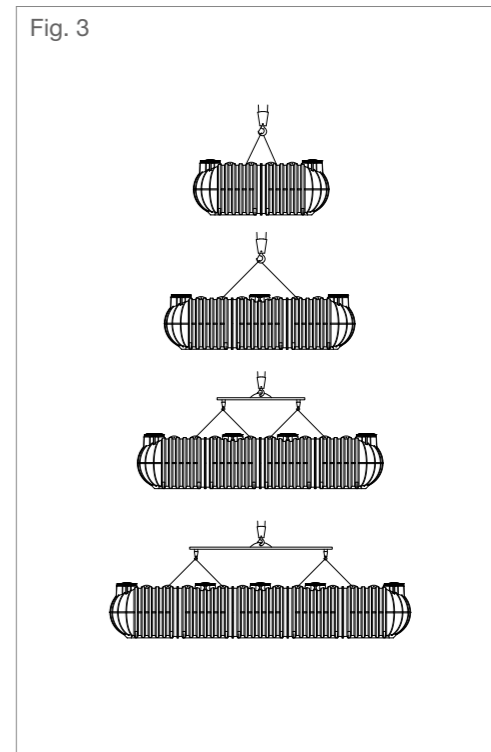
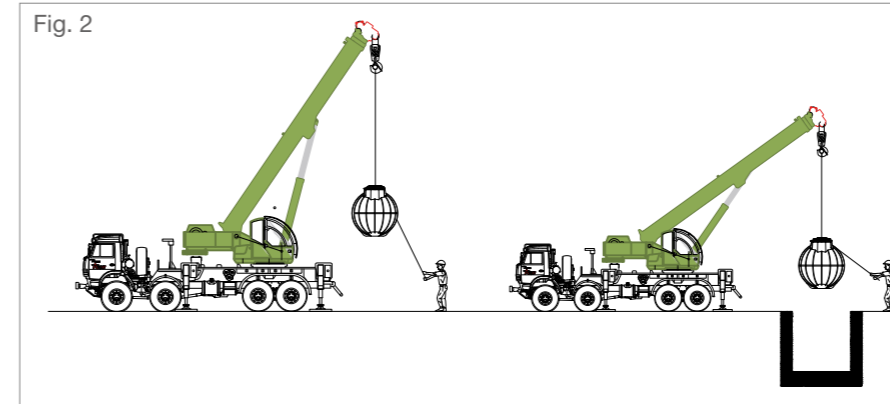
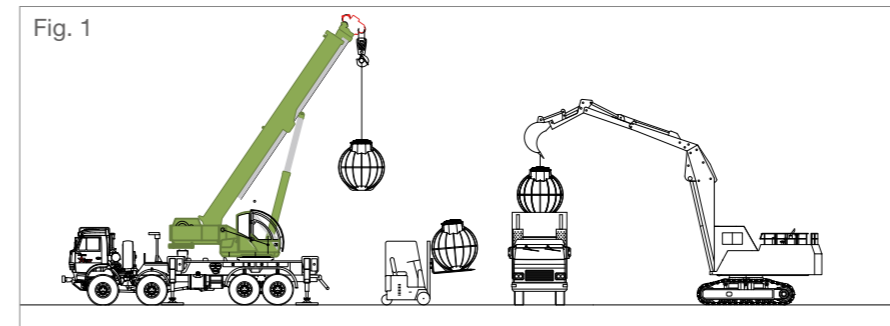

UNDERGROUND INSTALLATION

N.B. The best location for the tank is specified by the design engineer according to his own detailed technical assessment. These installation instructions provide the guidelines to follow during installation.

1. EXCAVATION

1.1 Excavate a hole of suitable dimensions with a flat bottom, leaving a space of at least 20/30 cm around the tank. In the presence of heavy soil (e.g. clayey subsoil and/or groundwater) the distance must be at least 50 cm. Spread a 15/20 cm deep layer of 20/30 mm washed gravel on the bottom of the excavation to allow the tank to rest on a uniform and level base. Excavated material must never be used as backfill. The excavation must be a minimum of 1m from any structures.

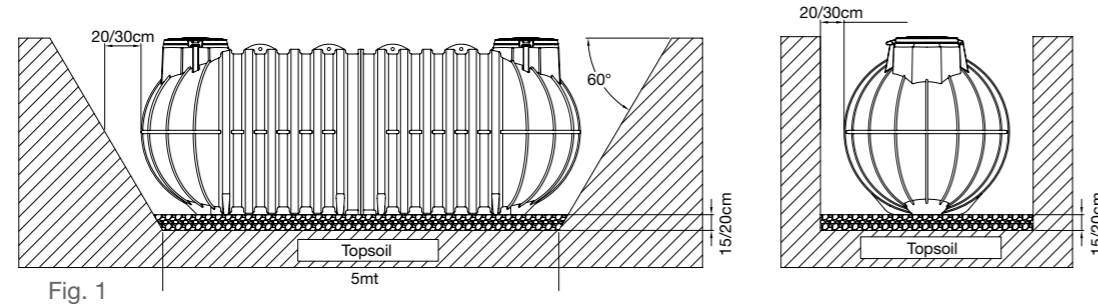

Fig. 1

2. BACKFILL AND FILLING

2.1 Place the totally empty tank on a bed of 20/30 mm washed gravel spread at the bottom of the excavation, gradually fill the tank with water and at the same time backfill with 20/30 mm washed gravel. Continue with successive layers of 15/20 cm, filling the tank and then backfilling with gravel. Fill the tank to 3/4 of its capacity and backfill the last 40 cm with topsoil (NOT clayey/limey material, NOT excavated material). To prevent excessive pressure on the tank, NEVER use backfill material with sharp edges. In the case of a tank with outlet pipe (e.g. aerobic trickle filters or gravity balancing tanks) seal the outlet pipe with a removable plug, then fill-backfill until half way up the tank, as indicated. After this, remove the plug and complete backfilling. Do not allow standing water to form in the excavation. N.B. For installation in more severe conditions (groundwater, clayey soils or in sloping ground), refer to chapter 3 "Exceptional Installation".

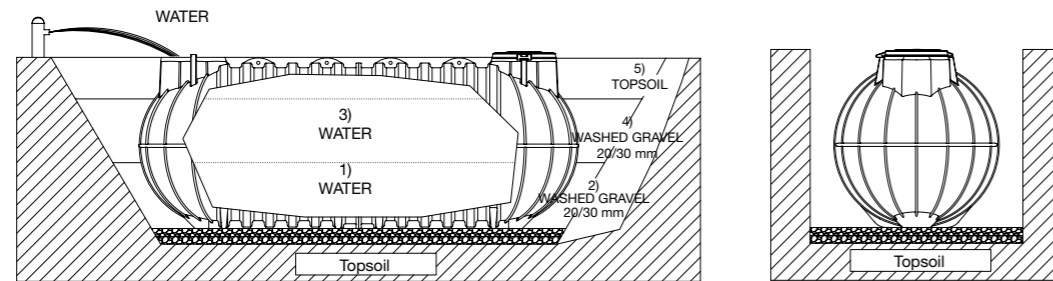

Fig. 2.1

2.2 After the tank has been filled and the excavation suitably backfilled, gradually cover with topsoil (NOT clayey/limey material, NOT excavated material) or with lightened material, e.g. expanded clay, to a depth of 30/40 cm, leaving the inspection covers exposed. In this way, the area concerned is suitable for pedestrian traffic, while the transit of motor vehicles within 2 m of the excavation is prohibited. When installing treatment plants, leave the tank filled with water. However, when installing a water storage tank, leave it full of water until the ground has fully settled (minimum 7 days. This period may vary based on the assessment of the designer). N.B. To render the site trafficable by motor vehicles, refer to chapter 4 "Trafficability". When installing treatment plants, leave the tank filled with water. However, when installing a water storage tank, leave it full of water until the ground has fully settled (minimum 7 days. This period may vary following an assessment by the designer). N.B. To render the site trafficable by motor vehicles, refer to chapter 4 "Trafficability".

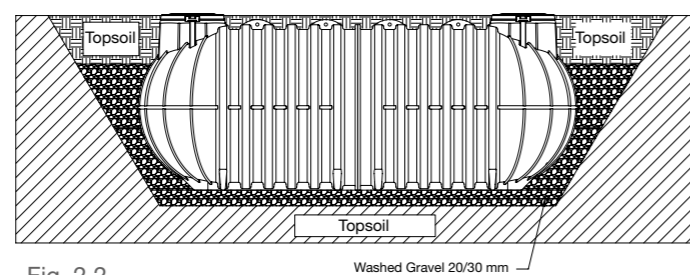

Fig. 2.2

UNDERGROUND INSTALLATION

2.3 EXTENSION INSTALLATION

If the tank is installed at a depth of 30/40 cm and the site is to remain open to pedestrian traffic, it is advisable to install the Rototec PE extension directly on the inspection holes. In the case where the tank is installed deeper than that previously indicated and more than one extension needs to be installed, which constitutes an unfavourable condition and not recommended, adhere scrupulously to the instructions reported in chapter 4 "Trafficability". The technician responsible for the installation will follow the instructions reported in the two paragraphs according to the installation depth.

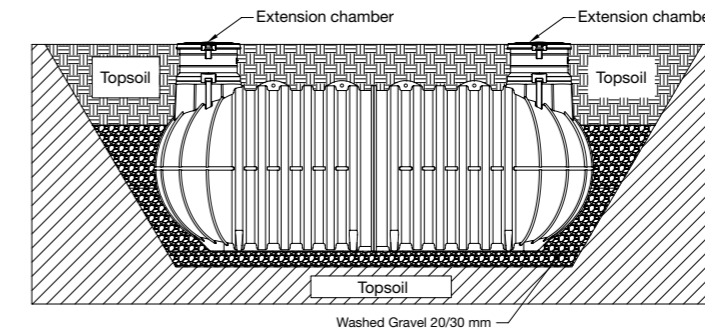

Fig. 2.3

2.4 PUMP/BIOGAS VENT CONNECTION

a) When installing a pump, whether internally or externally, ALWAYS install an open-air vent, free and correctly sized to prevent the formation of a vacuum and deformation of the tank when the pump is running. After connecting the vent, make the connections and check them. b) In order to prevent the formation of bad smells and, consequently, enable the treatment plant to function efficiently, ALWAYS connect a pipe (PVC, PP or PE) to the connection point provided for the biogas vent on the tank. Run the pipe to the highest point of the building or along the downpipes, but in any case higher than the level of the roof. The pipe indicated on the drawing for venting is not included in the supply.

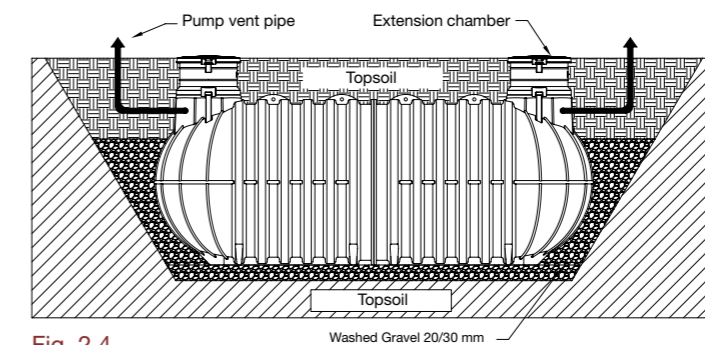

Fig. 2.4

2.5 MANHOLE INSTALLATION

The installation of manholes or covers of weight exceeding 50 kg must always be solid with the concrete slab, suitably designed for the load to support and exerting a uniformly distributed load over the tank. The slab, therefore, must NOT be constructed directly on the tank but must rest on undisturbed, load-bearing ground. AVOID constructions in brickwork which would compromise maintenance and/or eventual replacement of the tank.

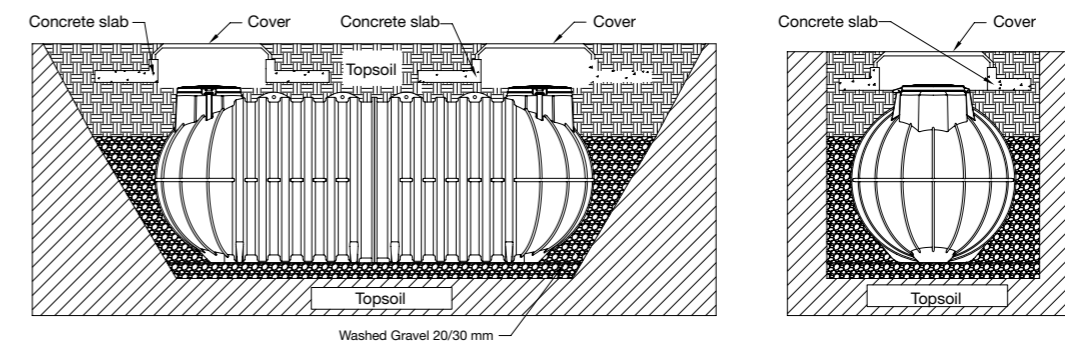

Fig. 2.5



SEWAGE



WATER



UNDERGROUND INSTALLATION



EXCEPTIONAL INSTALLATIONS

3.1 INSTALLATION IN ZONES WITH GROUNDWATER

Installation in the presence of groundwater is not recommended as it represents one of the riskiest conditions for a storage tank. In this case, it is advisable to obtain a geotechnical report from a specialist. From the report, the installation technician will be able to define the expected pressure from the groundwater and design the backfill material and slab accordingly. In particular, he will design the backfill to have the necessary capacity for resisting the high lateral forces. The resistance capacity can be increased by inserting an electro-welded steel mesh. Construct the concrete slab at the bottom of the excavation, then spread a 10 cm thick layer of 20/30 washed gravel over the top to fill in the voids between the corrugations in the base of the tank. The tank filling and backfilling operations must always be carried out progressively. It is advisable, therefore, to half fill the tank and at the same time backfill with concrete and allow it to stand for 24/36 hours [points 1-2]. Then complete the tank filling and the backfill [points 3-4].

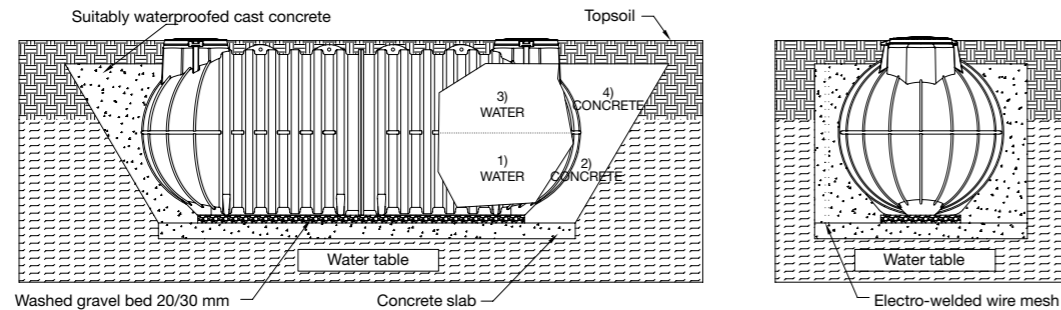

Fig. 3.1

3.2 INSTALLATION IN ZONES WITH CLAYEY/LIMEY SOIL

Installation in areas with a mainly clay/lime substrate and/or with limited drainage capacity is another unfavourable condition. A geotechnical report prepared by a specialist is advisable in this case also. From the report, the installation technician will be able to define the expected ground pressure (high in the case of clayey soil) and design the backfill accordingly. In particular, the bottom of the excavation must be covered by a bed of 20/30 washed gravel and the sides of the tank backfilled with 20/30 m gravel to aid drainage. For tank filling and backfilling, see para. 2.1. A drainage system must also be provided at the bottom of the excavation.

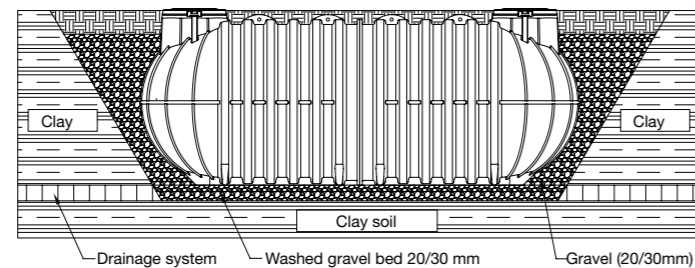

Fig. 3.2

3.3 INSTALLATION NEAR TO SLOPING GROUND

When the tank is to be installed near to a slope or on sloping ground, the tank must be protected by a reinforced concrete retaining wall, appropriately designed by a specialist, in order to balance the lateral thrust of the ground and to protect the area from possible infiltration. For tank filling and backfilling, see para. 2.1.

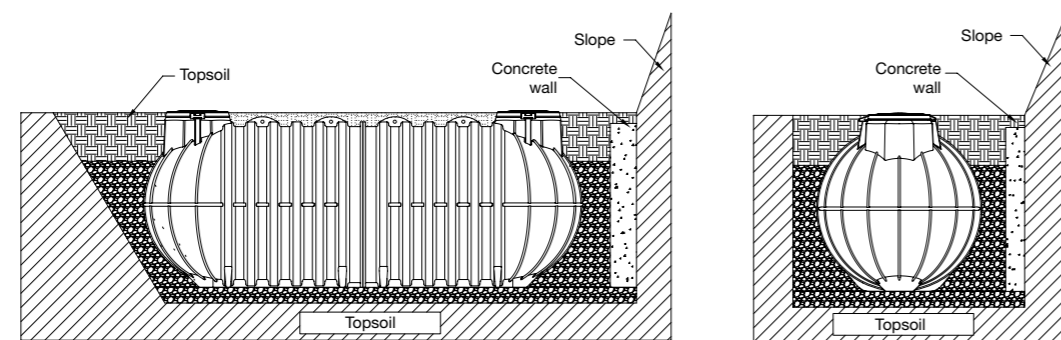

Fig. 3.3

TRAFFICABILITY

4.1 LIGHT TRAFFIC - CLASS B125-EN124/95 - MAX 12.5 TONS

To render the site suitable for the transit of light vehicles, a self-supporting reinforced concrete slab, designed in relation to the load, must be constructed. The perimeter of the slab must be larger than the excavation to prevent the weight of the slab from bearing on the tank itself. It is also advisable to construct a concrete slab (for example 15/20 cm thick) at the bottom of the excavation, over which a 10 cm thick layer of 20/30 mm washed gravel must be spread to fill in the voids between the corrugations in the base of the tank. The self-supporting slab in reinforced concrete and the bottom concrete slab must always be designed by a qualified professional. The tank filling and backfilling operations must always be carried out progressively as specified in para. 2.1. The self-supporting slab is necessary to distribute the load of the covering topsoil, even when the tank is installed at a depth > 40 cm, as indicated in paragraph 2.3.

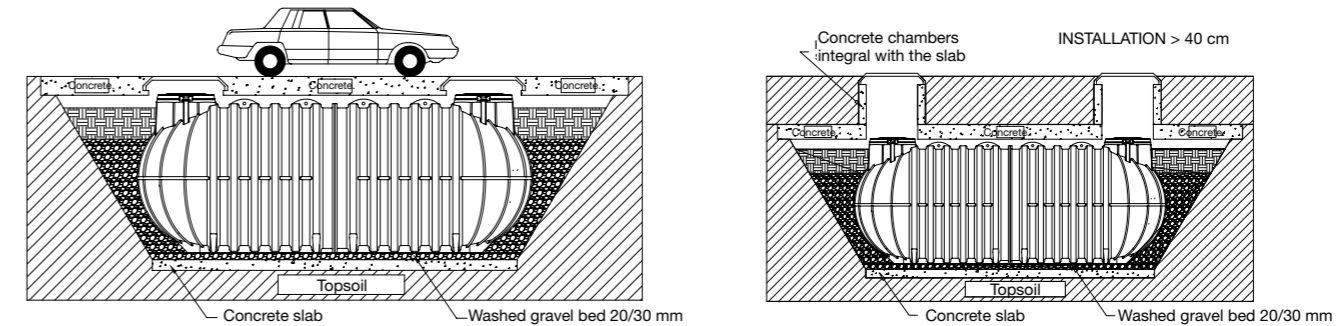

Fig. 4.1

4.2.A HEAVY TRAFFIC - CLASS D400-EN124/95 - MAX 40 TONS

To render the site suitable for the transit of heavy vehicles, a reinforced concrete containment structure cast on-site with a suitable self-supporting concrete cover slab must be provided. The perimeter of the slab must be larger than the excavation in order to distribute the load on the containment walls and not on the tank itself. Then spread a 10 cm thick layer of 20/30 mm washed gravel at the bottom of the containment structure to fill in the voids between the corrugations in the base of the tank. The containment structure and cover slab must be designed by a qualified professional in relation to the expected loads. The tank filling and backfilling operations must always be carried out progressively as specified in para. 2.1.

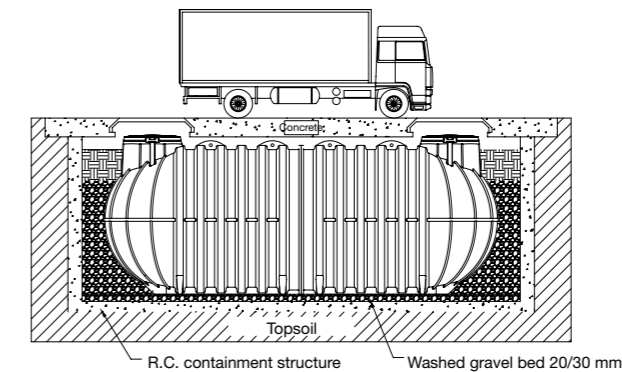
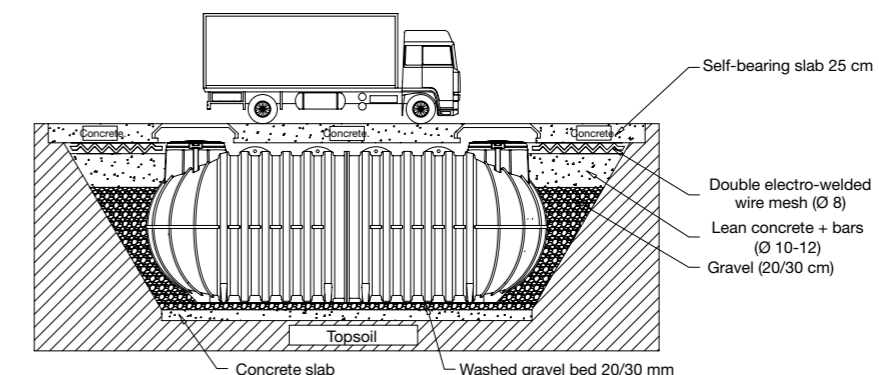

Fig. 4.2

4.2.B HEAVY TRAFFIC - CLASS D400-EN124/95 - MAX 40 TONS

To render the site suitable for the transit of heavy vehicles, a self-supporting reinforced concrete slab (≥ 25 cm) must be constructed. The perimeter of the slab must be larger than the excavation to prevent the weight of the slab from bearing on the tank itself. It is also advisable to construct a concrete slab (for example 15/20 cm thick) at the bottom of the excavation, over which a 10 cm thick layer of 20/30 mm washed gravel must be spread to fill in the voids between the corrugations in the base of the tank. The filling and backfilling operations to 3/4 must always be carried out progressively as specified in para. 2.1. After the tank has been filled and the excavation backfilled, gradually cover the last quarter of the excavation with lean concrete and bars ($\varnothing 10-12$). Create the self-supporting slab over these, using a double layer of electro-welded mesh ($\varnothing 8$) with spacers.



ACCESSORIES

[FIND OUT MORE](#)



SEWAGE



WATER



UNDERGROUND INSTALLATION



THREADED EXTENSION

Item	Ø mm	H mm	Cover Ø mm
PP30	300	300	210
PP35	435	300	300
PP35RIM	300	300	210
PP45	535	300	400
PP60RIM	535	300	400

Application: installing the extensions enables the tops of the tanks to be located below ground level. More than one extension can be used at the same time (See chapter on Underground installation)



HINGED TOP EXTENSION

Item	Ø mm	H mm	Cover Ø mm
PP77	750	430	630
PP25	750	250	630

Application: installing the extensions enables the tops of the tanks to be located below ground level. More than one extension can be used at the same time (See chapter on Underground installation)

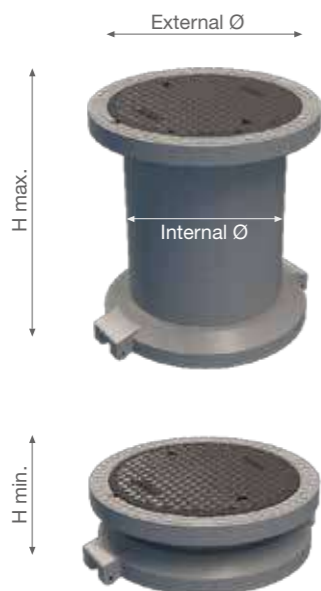

TELESCOPIC EXTENSION

Item	Internal Ø mm	External Ø mm	H min. mm	H max. mm
new PPTS720	600	880	200	900

Material: Chamber extension in one-piece linear high density polyethylene (LLDPE), black in color, for Rototec underground tanks with inspection hatch diam. 600 mm, equipped with polypropylene cover, rubber seal and systems fixing it to the manhole.

Function: the chamber extension allows the height of the inspection chamber to be adjusted according to the depth of the excavation. The extension can be lengthened or shortened easily thanks to its telescopic mechanism. This allows it to adapt to the various inspection needs, while always keeping the chamber at the required level.

Closing: to close, it is necessary to use the polypropylene cover mod. TAP720 (included).

Installation: carefully follow the "UNDERGROUND INSTALLATION INSTRUCTIONS" supplied by ROTOTEC.



EXTENSION MADE WITH WELDED SLEEVE

Item	DN
new 6TRPEMAN600	600

Application: The extension is made with a Magnum pipe sleeve welded to the tank. By inserting an additional pipe inside the sleeve, the extension can be used to adjust the tank installation height according to specific requirements. This modular system allows free selection of the installation level, providing maximum flexibility and ease of adaptation on site.



THREADED COVER IN PP WITH VENT*

Item	Internal Ø mm	External Ø mm
CS200	200	250
CS300	300	355
CS400	400	454

*supplied with above-ground tanks

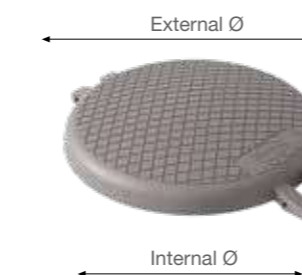

HINGED COVER IN PE

Item	Internal Ø mm	External Ø mm
TAP700*	630	800
TAP800*	630	800

* green colour available on request

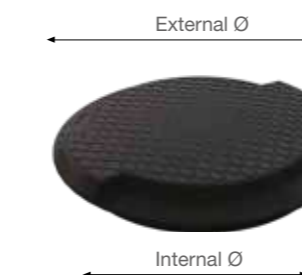

THREADED COVER IN PP*

Item	Internal Ø mm	External Ø mm
CC140	120	140
CC200	210	250
CC300	300	355
CC400	400	454
CC600	600	611

* supplied with treatment tanks



SEWAGE



WATER



UNDERGROUND INSTALLATION



COVER GASKET

Item	Internal Ø mm	Cover model
GC255	255	CC 200 - CS 200
GC355	350	CC 300 - CS 300
GC455	460	CC 400 - CS 400
GC600	620	CC 600
GC10700	630	TAP800

Application: the gaskets are used to improve the seal between the cover and the tank manhole on both above-ground and underground tanks. The gaskets are fitted directly onto the threaded or hinged cover (GC10700). Material: NBR rubber (model GC10700: adhesive gasket).



RING NUT

Item	External Ø mm	Internal Ø mm	Ring H mm
AF154	155	120	10
AF255	255	210	30
AF355	355	300	30
AF455	455	400	30
AF600	617	600	30

Application: the female threaded ring is installed and riveted on polyethylene tank manholes when custom inspection holes need to be created. Threaded covers can then be screwed into the rings.



GASKET

Item	External Ø mm	Internal Ø mm	L mm	Cutter Ø for gasket hole mm
GG50	95	50	8	60
GG63	110	63	8	75
GG80	125	80	8	89
GG100	145	100	8	102
GG110	150	110	8	115
GG125	160	125	10	135
GG125 S 15	160	125	13	135
GG160	200	160	10	162
GG200	230	200	10	207
GG250	280	250	10	255
GG315	345	315	10	323

Application: the rubber gaskets are used when it becomes necessary to install stub pipes on polyethylene tanks (e.g. to create inlets, outlets, etc.). When installed correctly, these gaskets provide a perfect seal.

Installation: a hole must be cut in the polyethylene tank using a circular hole cutter. The gasket is inserted into the hole. The stub pipe is then inserted in the gasket itself.



BRASS PIPE UNION

Item	D mm	Internal Ø mm	External Ø inches	L mm
BSO¼	47	19	¾"	75
BSO1	57	25	1"	85
BSO1 ¼	67	32	1 ¼"	91
BSO1 ½	75	38	1 ½"	96
BSO2	88	50	2"	107
BSO2 ½	108	63	2 ½"	128
BSO3	122	76	3"	158
BSO4	150	100	4"	209

Application: when installed on the special flat areas of the tanks, it allows the storage tank to be connected to the various draw-off systems for the liquid it contains: taps, irrigation systems, pumping systems. It also allows the tanks to be connected to each other (both underground and above-ground tanks) to provide very high storage volumes.

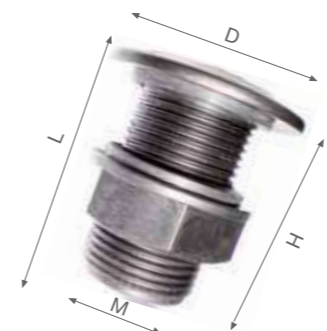

PIPE UNION IN POLYPROPYLENE

Item	M inches	H mm	L mm	D mm
BS¼	¾	41	46	46
BS1	1	46	51.5	50
BS1.5	1 ½	50	55	65.5
BS2	2	66.5	73.5	76
BS2 ½	2 ½	70	76	100

Application: when installed on the special flat areas of the tanks, it allows the storage tank to be connected to the various irrigation systems, pumping systems, etc. It also allows the tanks to be connected to each other (both underground and above-ground tanks).

ACCESSORIES



CONNECTING PIPE IN PE

Item	Ø mm
6TRPE040S	40
6TRPE050S	50
6TRPE063S	63
6TRPE075S	75
6TRPE090S	90
6TRPE125S	125
6TRPE160S	160
6TRPE200S	200
6TRPE250S	250

Description: stub pipes in smooth HDPE, extrusion welded to form a perfect waterproof seal.

Application: when installed on the tanks, it allows the storage tank to be connected to the various draw-off systems for the liquid it contains: taps, irrigation systems, pumping systems. It also allows the tanks to be connected to each other (both underground and above-ground tanks) to provide very high storage volumes.

COMPRESSOR BLOWER

Model	Voltage V	Frequency Hz	Power kW	Flow rate l/min	Noise level dB	Weight kg	Max length mm	Max. width mm	Max. height mm
HP40	230	50	38	40	<37	5.7	250	185	190
HP60	230	50	56	60	<39	7	250	185	196
HP80	230	50	78	80	<41	7	250	185	196
HP150	230	50	145	160	<50	9	300	230	230
HP200	230	50	186	200	<50	12	300	230	250

Description: diaphragm type air compressors used in activated sludge systems to develop an aeration system necessary for the aerobic bacteria digestion processes, making use of the electromagnetic vibration of an actuator rod supported by synthetic rubber diaphragms.

SIDE CHANNEL BLOWER

Model	Voltage V	Frequency Hz	Power kW	Amps A	Noise level dB	Weight kg
HP302SF	230	50	0.7	4.5	<55	15
HP402SF	380	50	1.6	5.6	<66	24
HP502SF	380	50	3	10	<72	38

Description: compressors-aspirators constructed in accordance with the side channel principle, operating both in aspiration and in compression. They are designed to operate continuously. Constructed in die-cast aluminium to guarantee maximum sturdiness and ease of handling. Special silencers contribute to its extremely low noise levels.

ELECTRIC TIMER PANEL

Item	Dimensions mm	Amps A	Power supply V
QST	210x210x100	6	230
QST3F (THREE-PHASE)	280x400x140	6	380

Description: electric panel controlling and protecting the diaphragm blowers serving activated sludge treatment plants. Thanks to the 24 hour segment timer, it is possible to set the blower to switch on and off automatically as required by the treatment plant.



ELECTRIC TIMER PANEL FOR DUAL BLOWER

Item	Dimensions mm	Amps A	Power supply V
QS2T	310x250x150	6	220

Description: electric panel controlling and protecting the diaphragm blowers serving activated sludge treatment plants. Thanks to the 24 hour segment timer, it is possible to set the blower to switch on and off automatically as required by the treatment plant.



SOCKET TIMER FOR BLOWERS

Item	Dimensions mm
TMP	70x70x40

Description: socket timer used to set the activation times of blowers-compressors. Fitted with segment timer with 15 minute intervals.



DIFFUSER PLATE

Item	Ø mm	Weight kg	Max. air flow rate m³/h	Bubbles ø mm	Flow rate l/min	Oxygenation capacity gO²/ Nm³ per metre of head
IFADN	214	2.1	5	1-3	40	18-20

Description: diaphragm type diffusers in microbored rubber used in activated sludge plants and designed to provide a uniform distribution of microscopic diameter air bubbles designed to optimise performance.



DIFFUSER DISC

Item	Ø mm	Weight kg	Max. air flow rate m³/h	Bubbles ø mm
IFADN250	250	1	5	1-3

Description: disc type membrane diffuser with rubber surface containing micro-holes that act as a valve, expanding to release air and re-closing to prevent water from entering once the flow has been interrupted.



SEWAGE



WATER



UNDERGROUND INSTALLATION



ACCESSORIES



TUBULAR DIFFUSER

Item	Diameter	Weight kg	Length	Max. air flow rate m ³ /h	bubbles ø mm
IFADNT600	2"	0.9	23.5	15.3	1-3

Description: air diffusers characterised by a rubber surface with micro-holes that act as a valve, expanding to release air and re-closing to prevent water from entering once the flow has been interrupted.



DIFFUSER KIT (IFADN)

Item	Pipe length mm
IFA 1D	according to the depth of the tank
IFA 2D	according to the depth of the tank

Application: when connected to a diaphragm type blower and to one or more diffuser plates and installed inside a tank, aerates and agitates the content, either continuously or intermittently.



CHLORINE TABLET

Item	Weight g	Diameter mm	Height mm
IFACC	200	75	25

Description: chlorine tablet consisting of trichloroisocyanuric acid with 90% active chlorine for long-lasting action. The disinfectant is released over a longer period of time (approximately 30-60 days) thanks to its particular molecular structure



FILTER MEDIA FOR TRICKLE FILTERS

Item	Shape	Dimensions mm	Specific surface area m ² / m ³	void index %	Dry weight Kg / m	Weight during service Kg / m ³	Material
BIOWE120	circular	170	120	approx. 95	38	approx. 350	Black isotactic polypropylene

Description: bulk filter media developed especially for the construction of medium-load trickle filter beds treating domestic or biodegradable industrial effluent. The advantages of using this type of filter media are linked to the high specific surface area and the high void index.



SINGLE DOSE BIOACTIVATOR SACHETS

Item	Description	Weight g
IFABIO	Single dose activator sachet for septic tanks	200

Function: biological activator in powder form, supplied in a single-dose sachet, to speed up the activation time of biological processes that normally develop in waste water treatment plants. Dissolve in a bottle of warm water and pour directly into the WC or into the tanks.



SPECIFIC CONCENTRATED BIOACTIVATOR

Item	Description	Weight g
IFABIODEG	Bioactivator specific for the activation of grease separators	750
IFABIOAN	Bioactivator specific for the activation of anaerobic treatment plants (septic or IMHOFF BIOLOGICAL TANKS, anaerobic trickle filters,...)	750
IFABIOIFA	Bioactivator specific for the activation of aerobic treatment plants (activated sludge plants, aerobic trickle filters,...)	750

Function: concentrated biological activator in powder form, supplied in a 750 g container, to speed up the activation time of biological processes that normally develop in sewage treatment plants. Dissolve in a bottle of warm water and pour directly into the WC or into the tanks. Available in three specific types for activation of the various tanks making up a treatment plant.



SEWAGE



WATER



UNDERGROUND INSTALLATION



ACCESSORIES



DRAINAGE PIPES

Description: corrugated and perforated PE pipe used as dispersion pipes in sub-irrigation systems. Available in diameters 100-125-160-200 mm.



AERATION SYSTEM FOR WATER STORAGE TANKS

Item
KIT AIR 40

KIT AIR 40

Aeration system consisting of:

- QST timed electric panel
- Blower model HP 40
- Diffuser plates model IFA DN
- Connecting pipes
- Cabinet excluded

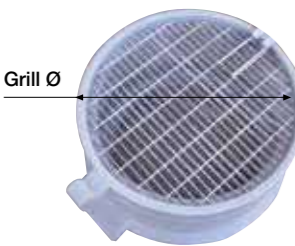

SAFETY GRILL

Item	Grill Ø mm	Mesh length mm	Mesh width mm
GRANT	730	75	30

Application: the pedestrian grill is a safety device that prevents unintentional entry into the tank.
Installation: the grill is fitted directly on the underground corrugated tank inspection hatch, (Cisterna, Panettone and Canotto) and is fastened using the pins provided. It can be mounted directly on the tank manhole or on a hinged cover extension.



ELECTRIC FLOAT

Item	Float dimensions mm	Cable length m	Amps A	Voltage V	Protection level	Max. temperature °C
GAL 5	80x100x40	5	10 (4)	250	IP 67	60

Application: float level switch for fresh water pump start/stop.



LEVEL ALARM KIT

Item
KALARM

KALARM

Application: alarm system that can be installed directly inside a storage tank, under the inspection manhole.
 The ALARM KIT is used to signal the level of the liquid in the tank according to the position at which the float valve is installed. It can be fitted on request in all underground, above ground or treatment tanks.
 It consists of an electric float valve fitted on a support rod; audible/visual alarm unit electric panel.

BACKFLOW VALVE



Item
KITSCIPP 125
KITSCIPP 160D
KITSCIPP 200D
KITSCIPP 250D
KITSCIPP 315D

Application: installed at the tank inlet, the valve automatically closes when the tank is completely full. IT IS essential that it be installed at the inlet to the stormwater run-off plant storage tanks.

FLOAT VALVE



Item
RAG

Application: The movement of the ball float ensures that the valve opens and closes automatically when the liquid in the tank reaches a certain level. The inclination of the arm and the position of the float can be adjusted to regulate the required valve opening and closing level. The valve is installed in the appropriate inlet holes in the tanks.

FILTER BASKET



Item
CF

Application filters out the coarse materials present in the collected rainwater (stones, leaves, tile residues, debris, etc...). The filter is fitted with a stainless steel handle to facilitate its removal from the chamber for cleaning purposes (removing residues, deposits). The leaf filter chamber FAPI is always supplied with the filter basket.

EXTERNAL LEVEL INDICATOR



Item
IL

Application: installed on the outside of storage tanks and used to monitor the level of the contained liquid by means of a plastic sphere.
 Warnings: when the indicator is installed on an above-ground tank, part of the liquid contained will be irradiated by sunlight. This could lead to the growth of algae. Consequently, it is not recommended when storing potable water.

ONE-PIECE POLYPROPYLENE CHAMBER



Item
PM20X20G
PM20X20V
PM30X30G
PM30X30V

Application: chamber used for water drainage, as a junction inspection chamber and as an extension for grease separators with separation baffles. Supplied with polypropylene (PP) cover.

ELECTROWELDABLE PE SLEEVE PN10



Item
MAN 90
MAN 125
MAN 160

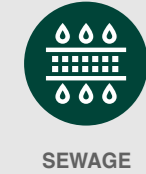

SEWAGE

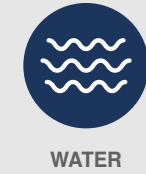

WATER

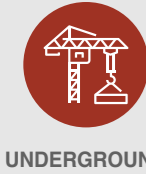

UNDERGROUND INSTALLATION



DEBRIS REMOVAL SYSTEM

SPECIFICATIONS

[FIND OUT MORE](#)



- 1 FRAME**
Galvanised iron frame supporting the load of the hopper and chute sections
- 2 HOPPER**
Polyethylene element with mouth that allows easy disposal of waste and rubble
- 3 CHUTE SECTION**
Polyethylene chute section with connecting chains

WARNINGS

- Use the rubbish chute in compliance with current site safety standards.
- Always cordon off the discharge area in a suitable manner in order to avoid danger to passers-by.
- The waste material to be disposed of must not be larger than the diameter of the chute outlet. This is to prevent blockage, breaking of the chains and the risk of the entire column falling.
- Inclining the chute is not recommended as this increases the risk of wear and possible damage, particularly where the elements form a curve. If a curved chute cannot be avoided, we recommend that the slope be gradual, checking that the chains are always fully tensioned.



FRAME



TECHNICAL CHARACTERISTICS

Galvanised iron frame with chains for connecting to the first chute section.

INSTALLATION

Attach to scaffolding or railings. Before use, make sure that the frame is firmly anchored to the support and that its fixing screws are correctly tightened. The hopper must be inserted in the frame and supported on its upper edge.

Item	Height mm	Min. length mm	Max. length mm	Width mm	Weight kg
XTE1	650	970	1450	710	14

HOPPER



TECHNICAL CHARACTERISTICS

Yellow linear polyethylene hopper. The width and ergonomic form of the mouth makes work much easier and faster.

INSTALLATION

To be positioned on the upper edge of the frame. Before installing the hopper on the frame, make sure that the frame itself is properly anchored and locked to the supporting scaffolding or railings.

Item	Height mm	Length mm	Width mm	Chute section bottom int. Ø mm	Chute section bottom ext. Ø mm	Weight kg
TR1	780	960	690	370	390	9

CHUTE SECTION



TECHNICAL CHARACTERISTICS

Chute section in yellow linear polyethylene, complete with fixing chains.

INSTALLATION

Assemble the chute by hooking-up the shackles supplied and inserting the chutes into one another by at least 20% of their length. The connecting chains must always be tensioned. It is advisable not to use more than 6 chute sections without anchoring them to an intermediate support (hopper and frame).

Item	Height mm	Useful height mm	Chute section top int. Ø mm	Chute section top ext. Ø mm	Chute section bottom int. Ø mm	Chute section bottom ext. Ø mm	Weight kg
TP1	1055	1000	500	580	370	390	8

DEBRIS DISCHARGE RETARDER



TECHNICAL FEATURES

Debris discharge retarders are accessories installed in the chute to reduce the fall speed of debris, minimizing pipe wear, excessive crushing, noise, and dust dispersion.

INSTALLATION

Installed inside each pipe or between the elements of the system, they act as brakes for the debris without fully blocking it.

Item	Material	Height cm	Ø external cm	Ø internal cm	Weight kg
XRL1	electro.galvanized steel	26	44	42	1.4

new

ROAD BARRIERS

[FIND OUT MORE](#)

SPECIFICATIONS



- 1 HANDLING GRIP
- 2 INTERLOCK SYSTEM
Male/female connection
- 3 PRESS-ON CAP
For filling with water
- 4 THREADED PLUG
For emptying

TECHNICAL CHARACTERISTICS

The top quality material (linear polyethylene) makes the barrier particularly resistant to impact, abrasion, sunlight and atmospheric agents. The original design, which allows the individual elements to be stacked, optimises both transport and storage. Available colours: Red and White

INSTALLATION

Modular safety device used as temporary boundaries or to channel vehicular traffic. The barrier is filled with water to a height of 14.5 cm (approx. 17 kg). The unique interlock system allows the individual elements to be angled to create even very tight curves.

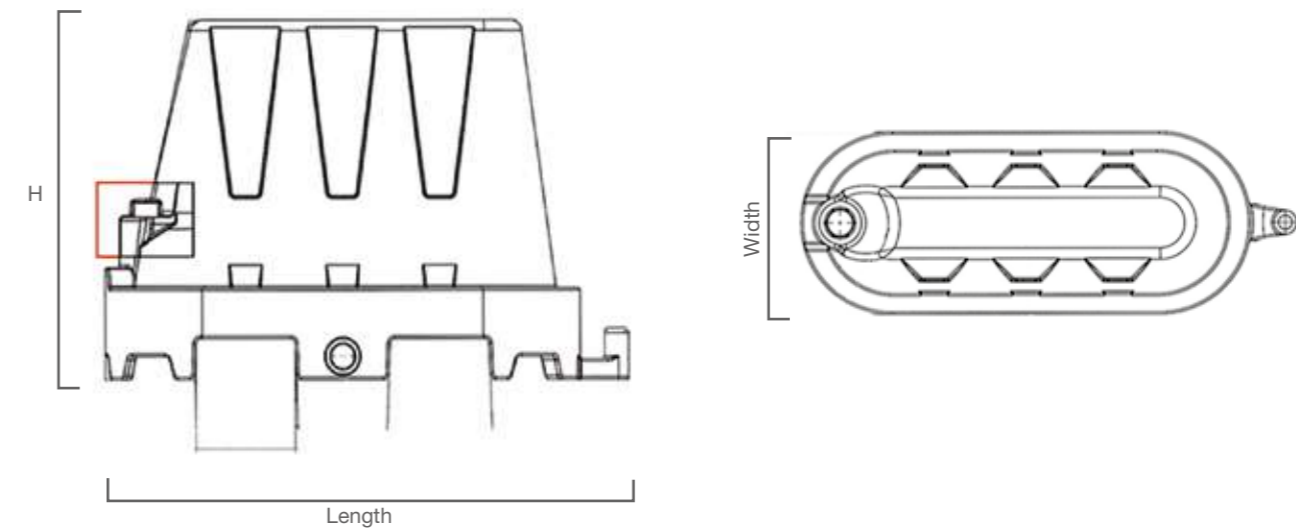

INSTALLATION AND STORAGE



Item	Height mm	Length mm	Width mm	Colour
XBSTRB	700	1000	400	White
XBSTRR	700	1000	400	Red



SEWAGE



WATER



UNDERGROUND INSTALLATION



MOVABLE BOLLARD

[FIND OUT MORE](#)

FUNCTION

ideal for discouraging vehicles from parking and for defining trafficable routes and temporary parking areas, routes for special vehicles, green areas, pedestrian zones, etc.

TECHNICAL CHARACTERISTICS

stackable movable bollard in rotomoulded linear polyethylene.

COLOUR

Yellow On request, bollards can be provided with refractive tape.

INSTALLATION

the bollard can be filled with water or sand through the threaded plug on the top to act as ballast.



Item	Height mm	Width mm	Capacity l	Weight with ballast Kg
XDIS500G	530	540	75	75/80

BARRIER

[FIND OUT MORE](#)

FUNCTION

cordoning off urban and working areas, building sites, car parks and events in general.

TECHNICAL CHARACTERISTICS

barrier and adjustable feet in polyethylene. Can be personalised by the application of adhesive labels/stickers

COLOUR

White

INSTALLATION

The barrier can be ballasted by filling the support feet with sand.



Item	Height mm	Length mm	Width mm	Width with feet mm	Barrier weight Kg	Filled foot weight Kg
XTRSB	900	2150	50	640	22	6.5

MULTI-USE BINS

[FIND OUT MORE](#)

TECHNICAL CHARACTERISTICS

Manufactured using special super-resins, recyclable and non-toxic, resistant to sudden changes in temperature (-60°C/+ 80°C), resistant to acids, washable using common detergents.

APPLICATION

The bins are designed for ease of handling and transport and can be stacked. They can be used for a variety of applications, work, hobbies, home, housing tools, equipment, fragile objects etc..

Item	Height mm	Width mm	Depth mm	Colours	Weight kg	Capacity l
BLT060NG	415	500	300	Black – Yellow	6	60



Item	Height mm	Width mm	Depth mm	Colours	Weight kg	Capacity l
BLT0120NG	415	600	500	Black – Yellow	11	120



Item	Height mm	Width mm	Depth mm	Colours	Weight kg	Capacity l
BLT240NG	415	1000	600	Black – Yellow	19.5	240



OIL DISPOSAL UNIT

[FIND OUT MORE](#)

- 1 HINGED TOP with safety seal.
- 2 DRAINAGE BASKET
- 3 USED FLUID EMPTYING HOLE: with threaded cap.
- 4 FLUID LEVEL INDICATOR
- 5 USED FLUID CONTAINER in polyethylene
- 6 OUTER SAFETY CONTAINER in polyethylene
- 7 LEAK INDICATOR

SPECIFICATIONS



CONTAINER FOR USED MINERAL OILS (ROTOIL)

Container for used mineral or synthetic lubricating oils, in particular oils from combustion engines and transmission systems, as well as mineral oils from machinery, turbines and hydraulic drives and from used filters (Legislative Decree No. 95 of 27th January 1992). Compliant with Legislative Decree No. 95 of 27th January 1992 (Implementing Directive 74/439/EEC on the elimination of used oils).

Item	External - internal colour	Capacity l	Ø mm	H mm
M300*	black-yellow	290	820	1080
M500*	black-yellow	500	960	1240
M1200	black-yellow	1100	1350	1270

* compliant with Legislative Decree No. 95 of 27 January 1992



CONTAINER FOR USED VEGETABLE OILS (ROTOVEG)

Container for vegetable and seed frying oils and, more rarely, olive oil, originating from restaurants, fast-food shops and kitchens in general. Complies with Legislative Decree 22/1997 (Ronchi Decree) incorporated in Legislative Decree 152/2006 that lays down the obligation to collect, recover and recycle used vegetable and animal greases and oils.

Item	External - internal colour	Capacity l	Ø mm	H mm
MV300	black-green	290	820	1080
MV500	black-green	500	960	1240
MV1200	black-green	1100	1350	1270



CONTAINER FOR ANTIFREEZE LIQUID (ROTOGEL)

Container for the temporary storage of used antifreeze.

Item	External - internal colour	Capacity l	Ø mm	H mm
MG300	black-blue	290	820	1080
MG500	black-blue	500	960	1240
MG1200	black-blue	1100	1350	1270



CONTAINER FOR ACIDS (ROKIM)

Container for the temporary storage of acids and chemical substances in general (e.g. used battery liquid,...). Please assess compatibility by consulting the table on page 306-307.

Item	External - internal colour	Capacity l	Ø mm	H mm
MK300	black-white	290	820	1080
MK500	black-white	500	960	1240
MK1200	black-white	1100	1350	1270



SEWAGE



WATER



UNDERGROUND INSTALLATION



MONOBLOC PORTABLE TOILETS

[FIND OUT MORE](#)

SPECIFICATIONS

Rototec portable toilets are made using special building elements that make them easy to use and to move. The cabin is fitted with everything required to guarantee maximum safety during transport and maximum ease of use. The portable toilets are delivered ready for use.





TECHNICAL CHARACTERISTICS

- 

1 VENTILATION PIPE
- 

2 POLYETHYLENE HINGE
- 

3 LATCH with vacant/engaged indicator and key lock
- 

4 STEEL EYE BOLTS for lifting and movement (optional)
- 

5 VENTILATION WINDOWS
- 

6 RAISED BASE to facilitate movement using fork lifts and pallet transporters

STANDARD ACCESSORIES

- 

MIRROR/HANGER
- 

DOUBLE TOILET ROLL HOLDER
- 

NON-SLIP FLOOR
- 

BAYONET PLUG FOR REFILLING (IF APPLICABLE)

TRANSPORT

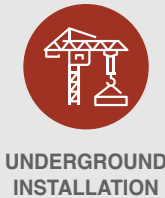
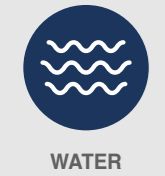

- GREASE SEPARATORS
- BIOLOGICAL TANKS
- BIOLOGICAL SEPTIC TANKS
- ACTIVATED SLUDGE PLANT
- TRICKLE FILTERS
- SECONDARY TREATMENT PLANT
- DEPURBLOK
- DEPURO
- STORMWATER MANAGEMENT
- CAR WASH PLANTS
- LIFT STATIONS
- CHAMBERS
- TECHNICAL SECTION
- IMHOFF BIOLOGICAL TANKS
- ABOVE-GROUND TANKS
- BIOLOGICAL SEPTIC TANKS
- ABOVE-GROUND MODULAR FIREFIGHTING TANKS
- CONSTRUCTION SITE EQUIPMENT
- UNDERGROUND TANKS
- RAINWATER HARVESTING AND RE-USE SYSTEMS
- OIL DISPOSAL UNIT
- PORTABLE TOILETS
- CHAMBERS
- TECHNICAL SECTION
- NON-STANDARD SOLUTIONS
- UNDERGROUND INSTALLATION
- ACCESSORIES



SEWAGE



WATER



UNDERGROUND INSTALLATION



MILANO



PORTABLE CHEMICAL TOILET WITH CLEAN WATER FLUSH

Portable chemical toilet complete with seat and clean water flush. Complete with all standard accessories.

OPERATION

It is made up of two completely separate tanks, one containing decomposing agent which receives the waste water (300 ml decomposing agent in 10 l of clean water) and the other, corresponding to the base containing clean water and 50 ml decomposing agent. The clean water is used to flush the pan using a pedal-operated diaphragm pump.

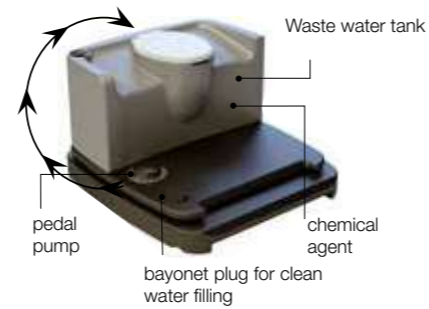

Item	Colour	Width mm	Depth mm	H mm	Door opening mm	Weight kg	Waste water tank volume l	Clean water volume l	Uses
BWA100VV	Green	1100	1100	2450	600 x 2000	95	170	100	approx. 200
BWA100BB	Blue	1100	1100	2450	600 x 2000	95	170	100	approx. 200
BWA100GG	Grey	1100	1100	2450	600 x 2000	95	170	100	approx. 200

ROMA



PORTABLE CHEMICAL TOILET WITH RECIRCULATION

Portable chemical toilet complete with seat and recirculating water flush. Complete with all standard accessories.

OPERATION

The waste water flows into the tank, where it is treated with decomposing agent (300 ml of decomposing agent in 10 l of clean water). It is then re-used to flush the pan by means of a pedal-operated diaphragm pump.

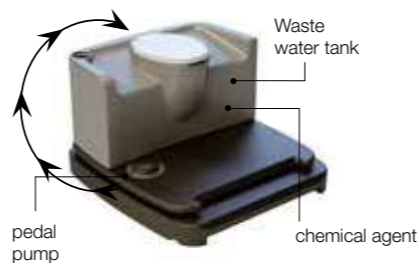

Item	Colour	Width mm	Depth mm	H mm	Door opening mm	Weight kg	Waste water tank volume l	Uses
BWR100VV	Green	1100	1100	2450	600 x 2000	95	170	approx. 200
BWR100BB	Blue	1100	1100	2450	600 x 2000	95	170	approx. 200
BWR100GG	Grey	1100	1100	2450	600 x 2000	95	170	approx. 200

TORINO



PORTABLE DROP TANK CHEMICAL TOILET

Portable chemical toilet without seat and flush, with tank. Optional pan flushing kit available. Complete with all standard accessories.

OPERATION

The waste water flows into the tank without seat, where it is treated with decomposing agent (300 ml of decomposing agent in 10 l of clean water). It is possible to install an optional recirculation kit which, by means of a manually operated pump, allows the waste water to be re-used to wash the pan.

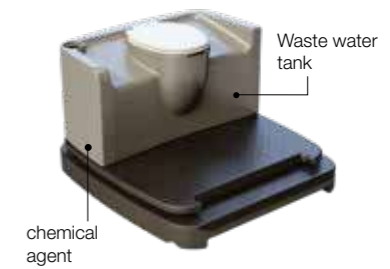

Item	Colour	Width mm	Depth mm	H mm	Door opening mm	Weight kg	Waste water tank volume l	Uses
BWC100VV	Green	1100	1100	2450	600 x 2000	95	170	approx. 200
BWC100BB	Blue	1100	1100	2450	600 x 2000	95	170	approx. 200
BWC100GG	Grey	1100	1100	2450	600 x 2000	95	170	approx. 200

BOLOGNA



PORTABLE CHEMICAL SQUAT TOILET WITH RECIRCULATION

Portable chemical squat toilet with recycled water flush. Complete with all standard accessories.

OPERATION

The waste water flows into the tank, where it is treated with decomposing agent (300 ml of decomposing agent in 10 l of clean water). It is then re-used to flush the squat pan by means of a pedal-operated diaphragm pump.

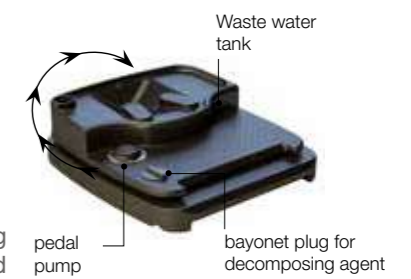

Item	Colour	Width mm	Depth mm	H mm	Door opening mm	Weight kg	Waste water tank volume l	Uses
BTR100VV	Green	1100	1200	2450	600 x 2000	90	170	approx. 200
BTR100BB	Blue	1100	1200	2450	600 x 2000	90	170	approx. 200
BTR100GG	Grey	1100	1200	2450	600 x 2000	90	170	approx. 200

DISASSEMBLED PORTABLE TOILETS







[FIND OUT MORE](#)

SPECIFICATIONS

Rototec introduces the revolutionary concept of the one-piece portable toilet. The fact that it can also be ordered in a collapsible version makes it highly original. This toilet is engineered so that it can be dismantled and this is its main strength, since it saves transport costs, optimizes loading space and simplifies storage: fundamental advantages both at national and international level.



TECHNICAL CHARACTERISTICS

						
1 VENTILATION PIPE	2 POLYETHYLENE HINGE	3 LATCH with vacant/occupied indicator and key lock	4 EYE BOLTS (4 pieces) for lifting	5 VENTILATION WINDOWS	6 OVERLAPPING BASE to facilitate movement using fork lift trucks and pallet transporters	OPTIONALS not assembled

STANDARD ACCESSORIES

			
MIRROR/HANGER	DOUBLE TOILET ROLL HOLDER	NON-SLIP FLOOR	BAYONET PLUG FOR REFILLING (WHERE APPLICABLE)

TRANSPORT



Volume optimised for transportation:
 Truck = 24 assembled toilets
 or 44 disassembled toilets
 40 HC = 20 assembled toilets
 or 38 disassembled toilets

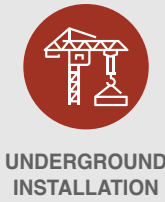
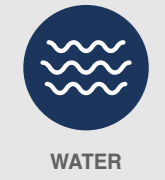



SEWAGE



WATER



UNDERGROUND INSTALLATION



PARIGI



PORTABLE CHEMICAL TOILET WITH CLEAN WATER FLUSH

Portable chemical toilet complete with seat and clean water flush. Complete with all standard accessories.

OPERATION

It is made up of two completely separate tanks, one containing decomposing agent which receives the waste water (300 ml decomposing agent in 10 l of clean water) and the other, corresponding to the base containing clean water and 50 ml decomposing agent. This is used to flush the pan by means of a pedal-operated diaphragm pump.

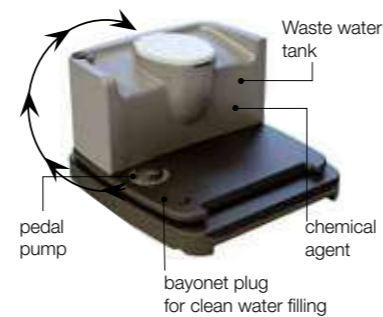

Item	Colour	Width mm	Depth mm	H mm	Door opening mm	Weight kg	Waste water tank volume l	Clean water volume l	Uses
BWA200VV	Green	1100	1100	2450	600 x 2000	95	170	100	approx. 200
BWA200BB	Blue	1100	1100	2450	600 x 2000	95	170	100	approx. 200
BWA200GG	Grey	1100	1100	2450	600 x 2000	95	170	100	approx. 200

BRUXELLES



PORTABLE CHEMICAL TOILET WITH RECIRCULATION

Portable chemical toilet complete with seat and recirculating water flush. Complete with all standard accessories.

OPERATION

The waste water flows into the tank, where it is treated with decomposing agent (300 ml of decomposing agent in 10 l of clean water). It is then re-used to flush the pan by means of a pedal-operated diaphragm pump.

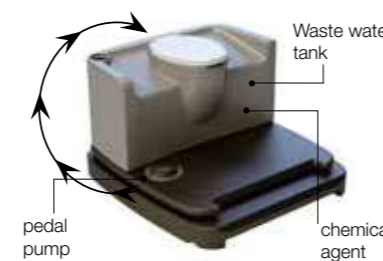

Item	Colour	Width mm	Depth mm	H mm	Door opening mm	Weight kg	Waste water tank volume l	Uses
BWR200VV	Green	1100	1100	2450	600 x 2000	95	170	approx. 200
BWR200BB	Blue	1100	1100	2450	600 x 2000	95	170	approx. 200
BWR200GG	Grey	1100	1100	2450	600 x 2000	95	170	approx. 200

VIENNA



PORTABLE DROP TANK CHEMICAL TOILET

Portable chemical toilet without seat and flush, with tank. Optional recirculation kit for flushing the pan. Complete with all standard accessories.

OPERATION

The waste water flows into the tank without seat, where it is treated with decomposing agent (300 ml of decomposing agent in 10 l of clean water). It is possible to install an optional recirculation kit which, by means of a manually operated pump, allows the waste water to be re-used to wash the pan.

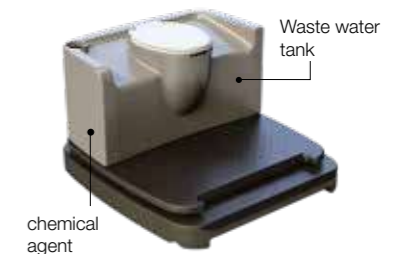

Item	Colour	Width mm	Depth mm	H mm	Door opening mm	Weight kg	Waste water tank volume l	Uses
BWC200VV	Green	1100	1100	2450	600 x 2000	95	170	approx. 200
BWC200BB	Blue	1100	1100	2450	600 x 2000	95	170	approx. 200
BWC200GG	Grey	1100	1100	2450	600 x 2000	95	170	approx. 200

MADRID



PORTABLE CHEMICAL SQUAT TOILET WITH RECIRCULATION

Portable chemical squat toilet with recycled water flush. Complete with all standard accessories.

OPERATION

The waste water flows into the tank, where it is treated with decomposing agent (300 ml of decomposing agent in 10 l of clean water). It is then re-used to flush the squat pan by means of a pedal-operated diaphragm pump.



Item	Colour	Width mm	Depth mm	H mm	Door opening mm	Weight kg	Waste water tank volume l	Uses
BTR200VV	Green	1100	1200	2450	600 x 2000	90	170	approx. 200
BTR200BB	Blue	1100	1200	2450	600 x 2000	90	170	approx. 200
BTR200GG	Grey	1100	1200	2450	600 x 2000	90	170	approx. 200

LIGHT - PORTABLE TOILETS

[FIND OUT MORE](#)

Rototec introduces the revolutionary concept of the one-piece lightweight portable toilet. The Light toilet can also be ordered dismantled.



SEWAGE



WATER



UNDERGROUND INSTALLATION



1
N° 4 EYEBOLTS for lifting (optional)



2
Latch with vacant/occupied indicator and key lock



3
VENTILATION WINDOWS



4
RAISED BASE For handling with fork lifts and pallet transporters

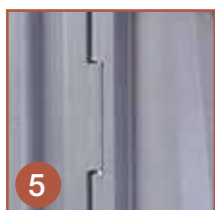

5
POLYETHYLENE HINGE



STANDARD ACCESSORIES



MIRROR/HANGER

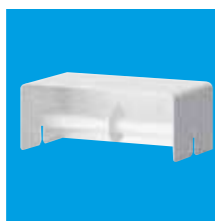

DOUBLE TOILET ROLL HOLDER



NON-SLIP FLOOR

TRANSPORT



Volume optimised for transportation:
Truck = 24 assembled toilets or 70 disassembled toilets
20 box = 10 assembled toilets or 25 disassembled toilets
40' HC = 20 assembled toilets or 50 disassembled toilets

BRUXELLES LIGHT



PORTABLE CHEMICAL TOILET WITH RECIRCULATION

Portable chemical toilet complete with seat and recirculating water flush. Complete with all standard accessories.

OPERATION

The waste water flows into the tank, where it is treated with decomposing agent (300 ml of decomposing agent in 10 l of clean water). It is then re-used to flush the pan by means of a manually operated diaphragm pump.



Item	Colour	Width mm	Depth mm	H mm	Door opening mm	Weight kg	Waste water tank volume l	Uses
BWR300VG	Green/grey	1007	1007	2252	670 x 1950	± 73	250	approx. 300
BWR300BG	Blue/grey	1007	1007	2252	670 x 1950	± 73	250	approx. 300

VIENNA LIGHT



PORTABLE DROP TANK CHEMICAL TOILET

Portable chemical toilet without seat and flush, with tank. Optional recirculation kit for flushing the pan. Complete with all standard accessories.

OPERATION

The waste water flows into the tank without seat, where it is treated with decomposing agent (300 ml of decomposing agent in 10 l of water). It is possible to install an optional recirculation kit which, by means of a manually operated pump, allows the waste water to be re-used to wash the pan.



Item	Colour	Width mm	Depth mm	H mm	Door opening mm	Weight kg	Waste water tank volume l	Uses
BWC300VG	Green/grey	1007	1007	2252	670 x 1950	± 73	250	approx. 300
BWC300BG	Blue/grey	1007	1007	2252	670 x 1950	± 73	250	approx. 300



PORTABLE DISABLED TOILETS

SPECIFICATIONS

[FIND OUT MORE](#)



SEWAGE



WATER



UNDERGROUND INSTALLATION



Grab rails



Double toilet roll holder



Ventilation grills

TECHNICAL CHARACTERISTICS

Rototec has developed the Portable Disabled Toilet to meet needs of physically impaired persons and to allow everyone to participate at events.

The wide entrance door and obstacle-free access are designed to allow the passage of a wheelchair. Internally, the user can quite easily move in total safety, thanks to the spaciousness of the compartment, enabling full 360° mobility and easy seating, together with the presence of grab rails on the walls. The Portable Toilet is built in anti-UV stabilised polyethylene (PE) and is 100% recyclable. The portable toilets are delivered ready for use.

REFERENCE STANDARDS

UNI EN 16194:2012.

INTERNAL FITTINGS

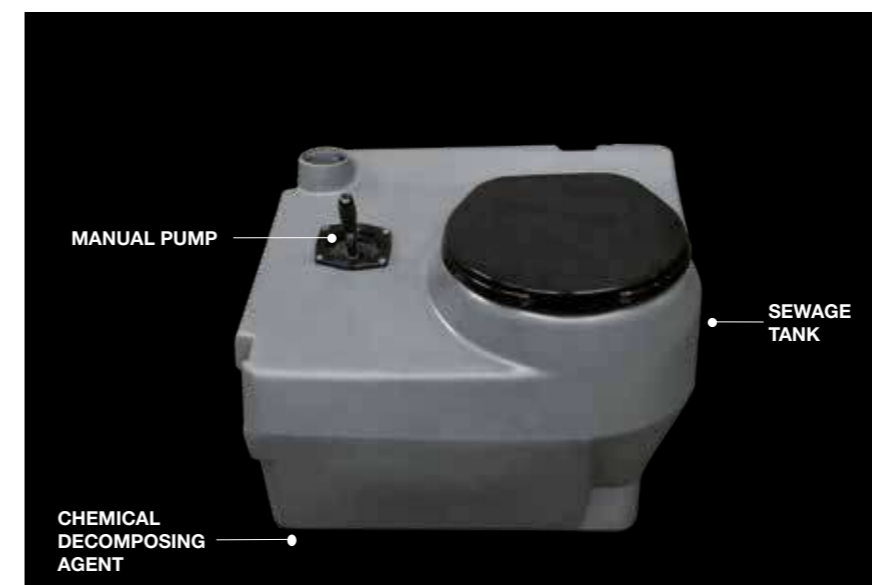

Seat with chemical toilet and recirculation flush.

The sewage enters the specially designed tank and is treated with a decomposing agent. The waste water is then re-used to flush the bowl by means of a manually operated diaphragm pump.

Plenty of manoeuvring space, ergonomic, easy access thanks to the step-free ramp.

MAXI PRAGA

DISABLED PORTABLE CHEMICAL TOILET WITH RECIRCULATION

Item	Colour	Width mm	Depth mm	H mm	Door opening m	Weight kg	Sewage holding vol. l	Waste water tank H mm
BDWR500VV	Green	1550	1550	2200	900 x 1870	127	150	495
BDWR500ZZ	Blue	1550	1550	2200	900 x 1870	127	150	495



ACCESSORIES

WASHBASIN



WASHBASIN
Washbasin with pedal-operated diaphragm pump, complete with fill plug.

Item	Capacity	No. of uses
BLAV 100	60	170



LIGHT TOILET WASHBASIN
Washbasin with pedal-operated diaphragm pump, complete with fill plug.

Item	Capacity	No. of uses
BLAV300	40	115



WASHBASIN
Suspended washbasin with water supply from the mains or from a storage tank.

Item
BLAVM100



WASHBASIN WITH MANUAL PUMP KIT
Washbasin with manual pump, complete with fill plug.

Item
BLAV100DPM

URINAL



URINAL
Wall-mounted urinal. Outlet discharges to the sewage holding tank. Available for the Milano, Roma and Torino models.

Item
BORI



URINAL TABLETS
Perfumed tablets with lemon fragrance.

Item	Q.ty pcs
BPORI 20	20
BPORI 50	50

RECIRCULATION KIT



RECIRCULATION KIT
Manual pumping system for toilet bowl flushing with recirculated water. Consisting of a manual pump, scratch-proof sanitary ware bowl and piping with filter. Available for the Torino model.

Item
BKRC

DEODORIZING/DECOMPOSING AGENTS



LIQUID CHEMICAL DECOMPOSING AGENT
Tank of deodorizing and decomposing syrup

Item	Capacity
BLDIS 5	5
BLDIS 20	20
BLDIS 50	50



CHEMICAL DECOMPOSING AGENT EVENT
Soluble packets for use in the case of heavy traffic and high temperatures.

Item	Quantity pcs
BBDIS 50	85



DEODORANT DISKS
Felt disks impregnated with a blackberry fragrance, for hanging in the toilet.

Item	Q.ty pcs
BPDEO 100	100

SANITISING PRODUCTS



SANITISING HAND GEL
Quick-drying rapid sanitising hand gel to be used directly or as a refill for dispensers.

Item	Packaging
IGLV1000	500 ml plastic bottle



LIQUID SANITISER
Activated oxygen-based liquid additive to sanitise surfaces.

Item	Packaging
IGTP1000	500 ml plastic bottle



HAND WASHING SOAP
Sanitising hand washing soap.

Item	Capacity
BCGEL	1



DISPENSER
Hand washing gel dispenser.

Item
BDISP



TOWEL HOLDER WITH TOWELS

Item	Components
PSVBC	towel holder + 100 towels



SANITISING MAT
Mat with sanitising liquid.

Item	Size width x length
TPIG4070	40X70 cm

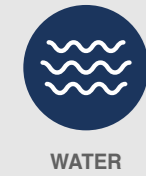



SEWAGE



WATER



UNDERGROUND INSTALLATION



PROJECT 3: PANAMA

DESCRIPTION OF THE PROJECT:

Waste water treatment plant located in Panama with the aim of treating the water coming from residential buildings and re-using it for irrigation of green areas. Due to the number of population equivalent, the customer decided to install several plants in parallel to guarantee capacity and efficiency.

ROTOTEC'S SOLUTION:

Rototec designed a modular parallel treatment system, with interconnected units that comply with environmental regulations. It includes advanced, real time treatment and monitoring technology, optimising efficiency and guaranteeing compliance with environmental standards is fully adapted to the existing infrastructure thanks to its flexibility.

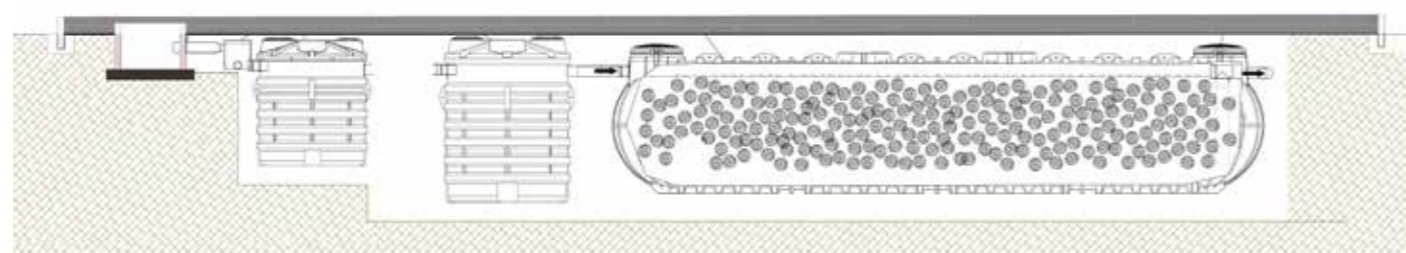
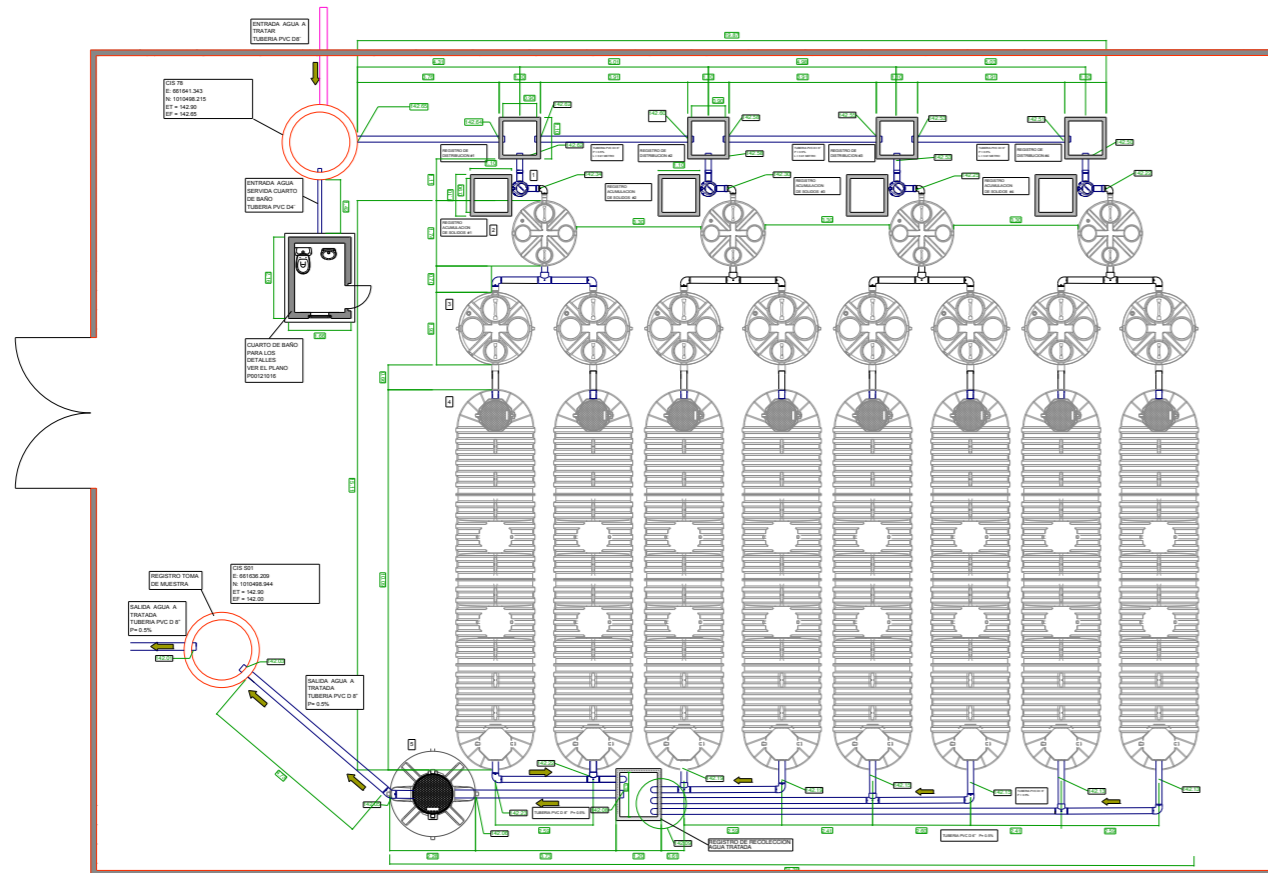



SEWAGE



WATER



UNDERGROUND INSTALLATION



PROJECT 4: FRANCE

DESCRIPTION OF THE PROJECT:
Rototec has created a 220 m³ storage tank for fire protection, custom designed to satisfy the specifications of the customer.

ROTOTEC'S SOLUTION:
The system was given a customised form due to the restricted space around the manufacturing plant, using the modular features of Infinittank basic elements. This solution has allowed the plant to adapt perfectly to the available space limitations, while at the same time retaining the efficiency and functionality required. The design innovation optimised space without compromising storage capacity of firefighting safety, responding with precision to the customer's needs.

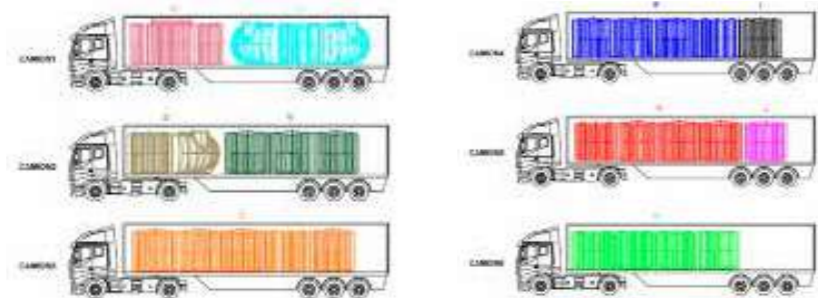



Rototec S.p.A
Via dell'Artigianato, 6
61026 Lunano (PU)
Company subject to management
and coordination by HB Boscarini S.p.A.

Web. Rototec.it
Tel. (+39) 0722 7228
Fax. (+39) 0722 70599

export.marketing@tubi.net
info@rototec.it
  

 **SYSTEM GROUP**
www.tubi.net
  

ISO 9001
BUREAU VERITAS
Certification
Certificate N° IT309902
