

20 1999/2019



SEWAGE DIVISION

RO TO TEC

2021
GENERAL
CATALOGUE

en

RO TO TEC

2021
SEWAGE
DIVISION
CATALOGUE

CO M P A N Y



SAVING THE FUTURE





SYSTEM GROUP

STEPS
towards
the future.

www.tubi.net

SAVING
THE
FUTURE

esperienza
passione
innovazione
ricerca
tecnologia
software
riciclo
recupero

ROTOTEC THE COMPANY

Rototec S.p.A. is a dynamic company in continuous expansion present throughout Italy and abroad. The company was founded in 2000 as part of the System Group, a leader in the production of complete pipeline systems (pipes, fittings, specials,...).

It was soon specializing in the production of corrugated and smooth tanks in linear polyethylene manufactured using rotational moulding technology. Over the years, Rototec S.p.A. has always felt the need to distinguish itself on the Italian and international markets, investing its resources in research and in updating its own production to meet European standards, in order to provide its

customers with increasingly high performance and reliable treatment systems that will contribute even more to the defence of our land. Increasing awareness of aspects regarding environmental protection and regulatory updates have become two of Rototec's strategic aims, which are pursued using real time communication channels (Facebook, LinkedIn, web site, newsletters, apps, etc...) and more traditional channels such as organisation of training meetings, seminars and study days with the co-operation of local Authorities, Universities and professional Bodies and Organisations.





ROTOTEC SERVICES

- › Organisation of training meetings, technical seminars and in-house training
- › A large network of agents and retailers throughout Italy and abroad
- › Design work during the plant sizing phase
- › Digital support during design work using tools such as:
 - . plant configuration software
 - . bim libraries
 - . website updated in real time
- › Prompt delivery
- › On-site technical support
- › After-sales service



PERSONE
INNOVAZIONE
TECNOLOGIA



TRIPRESSA PER DISIDRATAZIONE FANGHI

SYSTEM GROUP

SYSTEM GROUP in the world

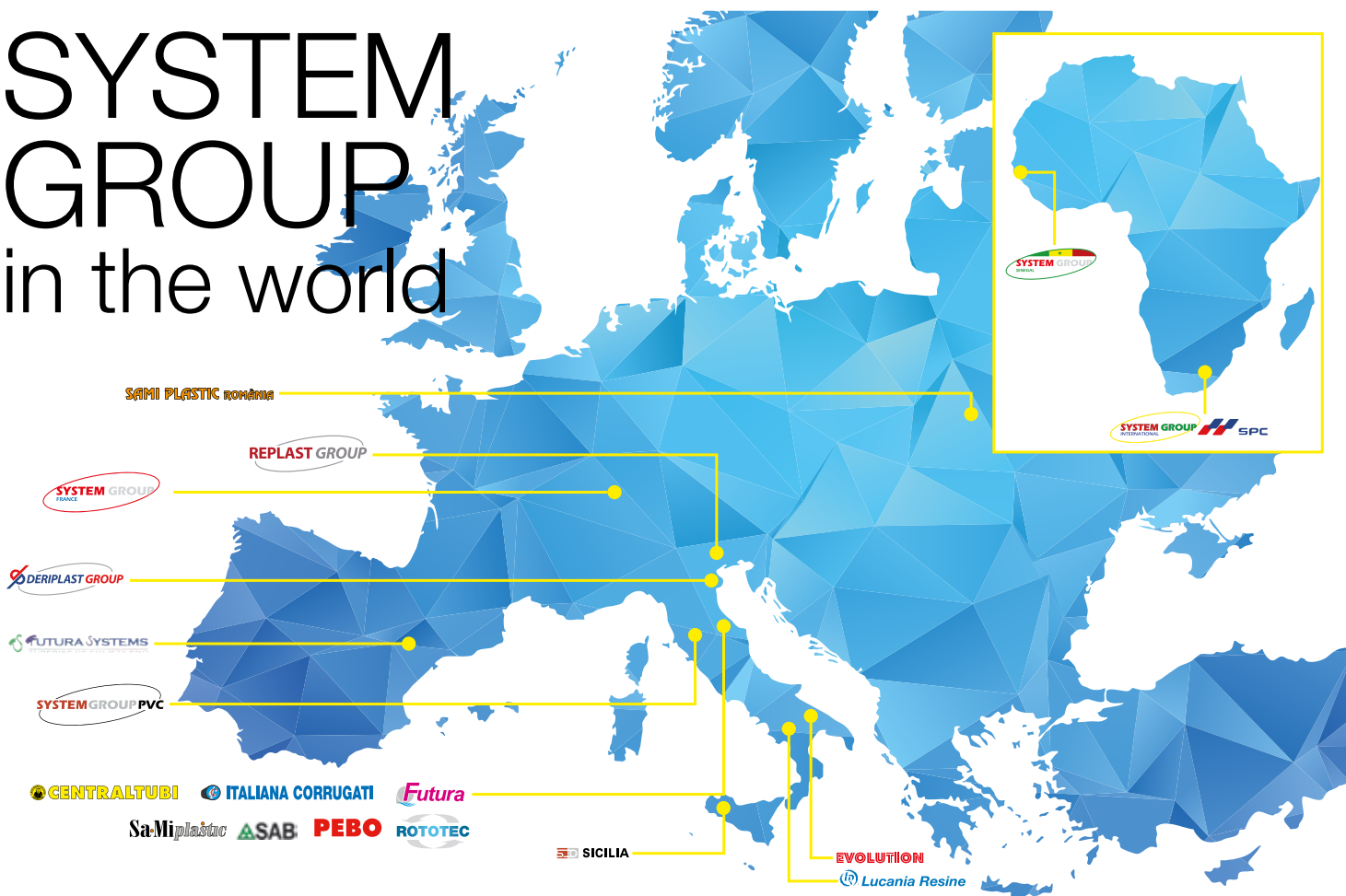

ROTOTEC & SYSTEMGROUP

System Group was created in a small town inland of Pesaro (Lunano) as a result of an idea by entrepreneur Alvaro Boscarini who, in 1979, had founded Centraltubi for the production of polyethylene pipes. The group was formed at the start of the 1990's when **Centraltubi** was joined by **Futura**, a company operating in the pipe fittings, accessories and specials market. These were to be the first steps on the road to success which, in the following years, saw the birth of five other important businesses: **Sa.Mi Plastic** (smooth polyethylene pipes and multilayer pipes for water, heating and sanitary systems), **Pebo** (production of plastic materials), **Italiana Corrugati** (corrugated polyethylene pipes), **Rototec** (rotational moulding of tanks) and **Mecsystem** (engineering).

In response to the ever increasing demand, **System Group** then expanded its sales network to other European countries, with the construction of new production facilities in Spain (**Futura Systems**), in France (**System Group France**) and in Romania (**Sa.**

Mi Plastic Romania). The group further reinforced its position in the production of special fittings thanks to the acquisition and expansion of a company already operating in the sector, Sab located in Sirolo (AN), which subsequently moved to Sant'Angelo in Vado.

Finally, the acquisition of **Lucania Resine**, a company with 20 years experience in the field of piping, allowed the group to obtain a strategic position that would enable it to logistically enter the market in Southern Italy.

The last few years have seen a continuation of the constant and concentrated efforts of the System Group to reach its objectives of an increased and more consistent cover of the Italian and foreign markets, satisfying the demands by broadening its range of products and entering new market sectors (**Deriplast, Replast, System Group PVC, System Group Sicilia**).





p.	12	SEWAGE DIVISION
p.	190	UNDERGROUND INSTALLATION
p.	198	ACCESSORIES
p.	208	OTHER PRODUCTS



SEWAGE DIVISION



p. 14	EXAMPLE OF PLANT SOLUTIONS
p. 16	CALCULATION OF POPULATION EQUIVALENT
p. 17	CERTIFICATIONS
p. 18	GREASE SEPARATORS
p. 28	IMHOFF BIOLOGICAL TANKS
p. 40	BIOLOGICAL SEPTIC TANKS
p. 48	SEWAGE TREATMENT PLANTS - DEPURO
p. 64	ACTIVATED SLUDGE PLANTS
p. 78	TRICKLE FILTERS
p. 92	HIGH EFFICIENCY SECONDARY TREATMENTS
p. 100	DEPURBLOK
p. 120	GRIT SEPARATORS
p. 124	COALESCING FILTER TYPE OIL SEPARATORS
p. 132	COALESCING OIL SEPARATOR WITH INTEGRATED BYPASS
p. 138	CONTINUOUS STORMWATER RUNOFF TREATMENT PLANTS
p. 146	BALANCING TANKS
p. 156	TREATMENT PLANTS FOR CAR WASHES
p. 166	LIFT STATIONS
p. 184	CHAMBERS

EXAMPLE OF PLANT SOLUTIONS

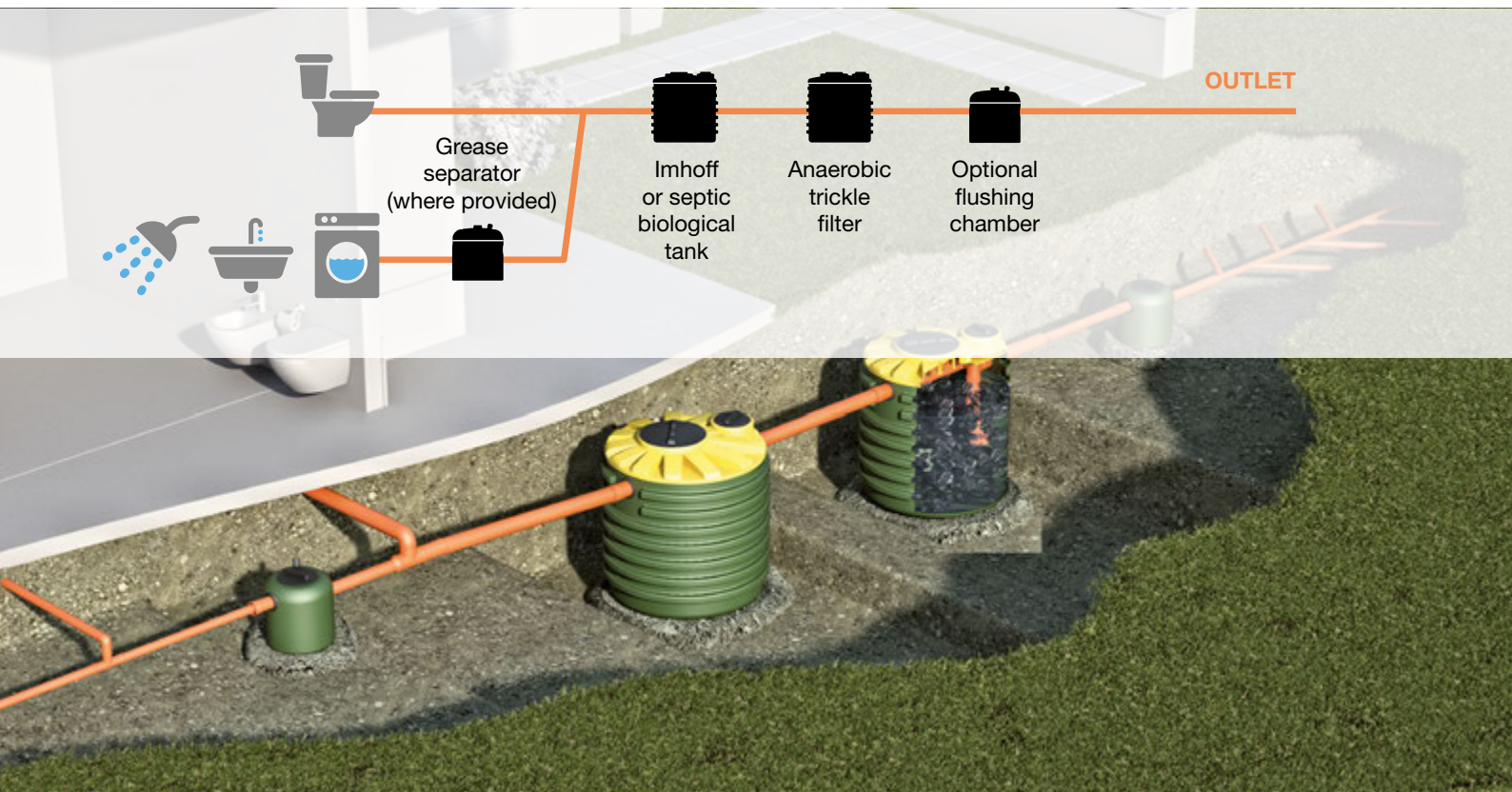
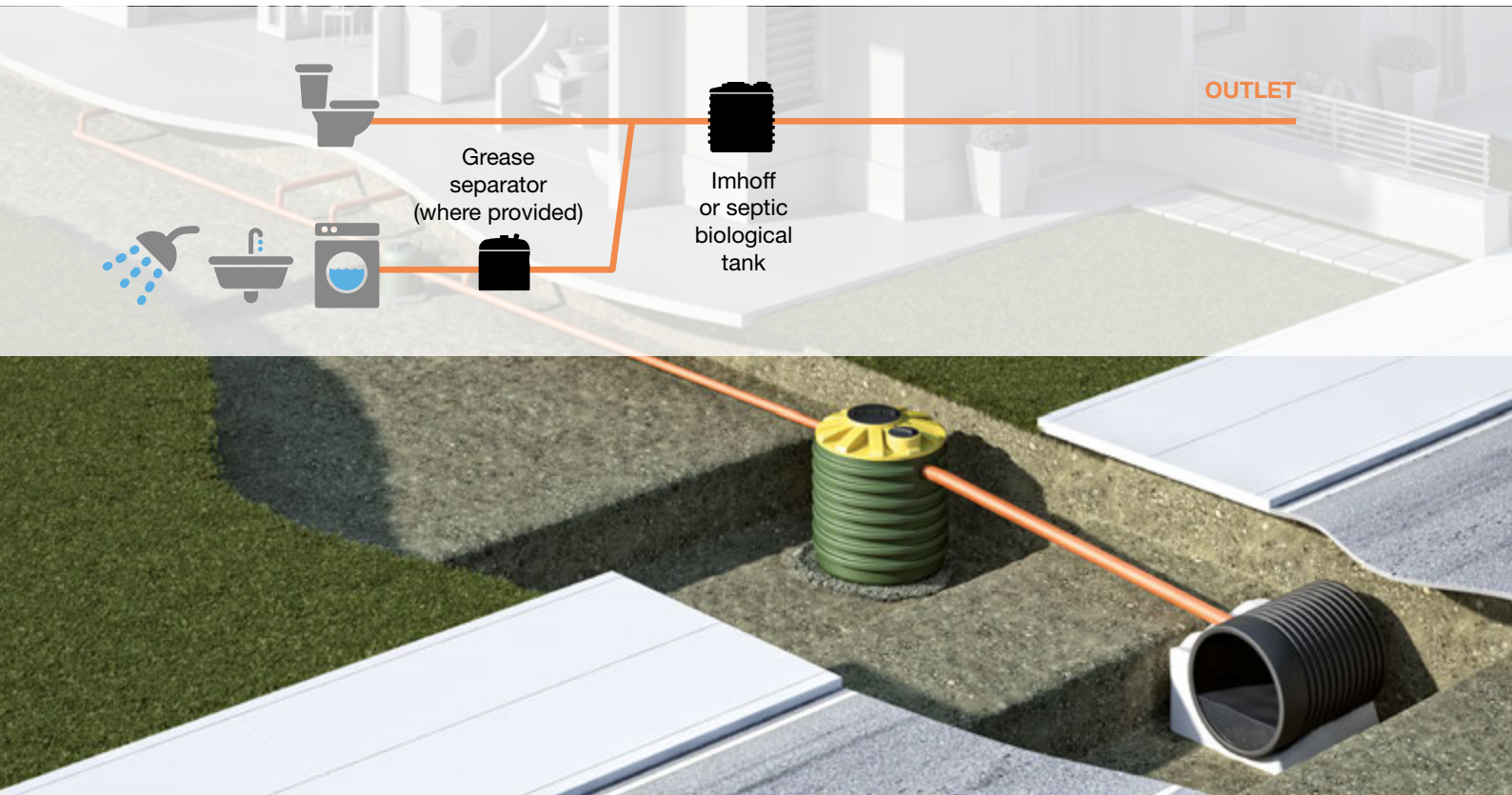

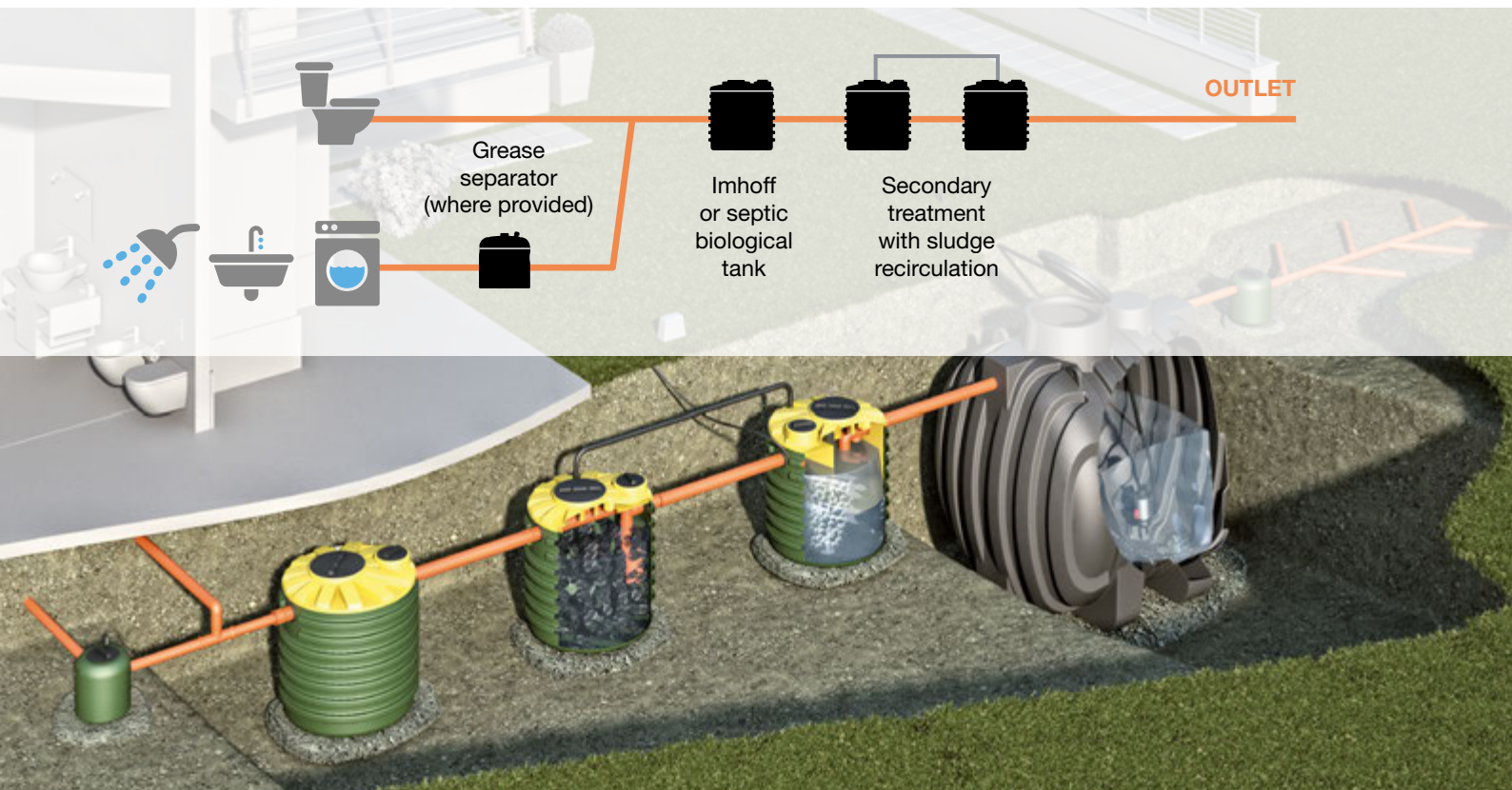
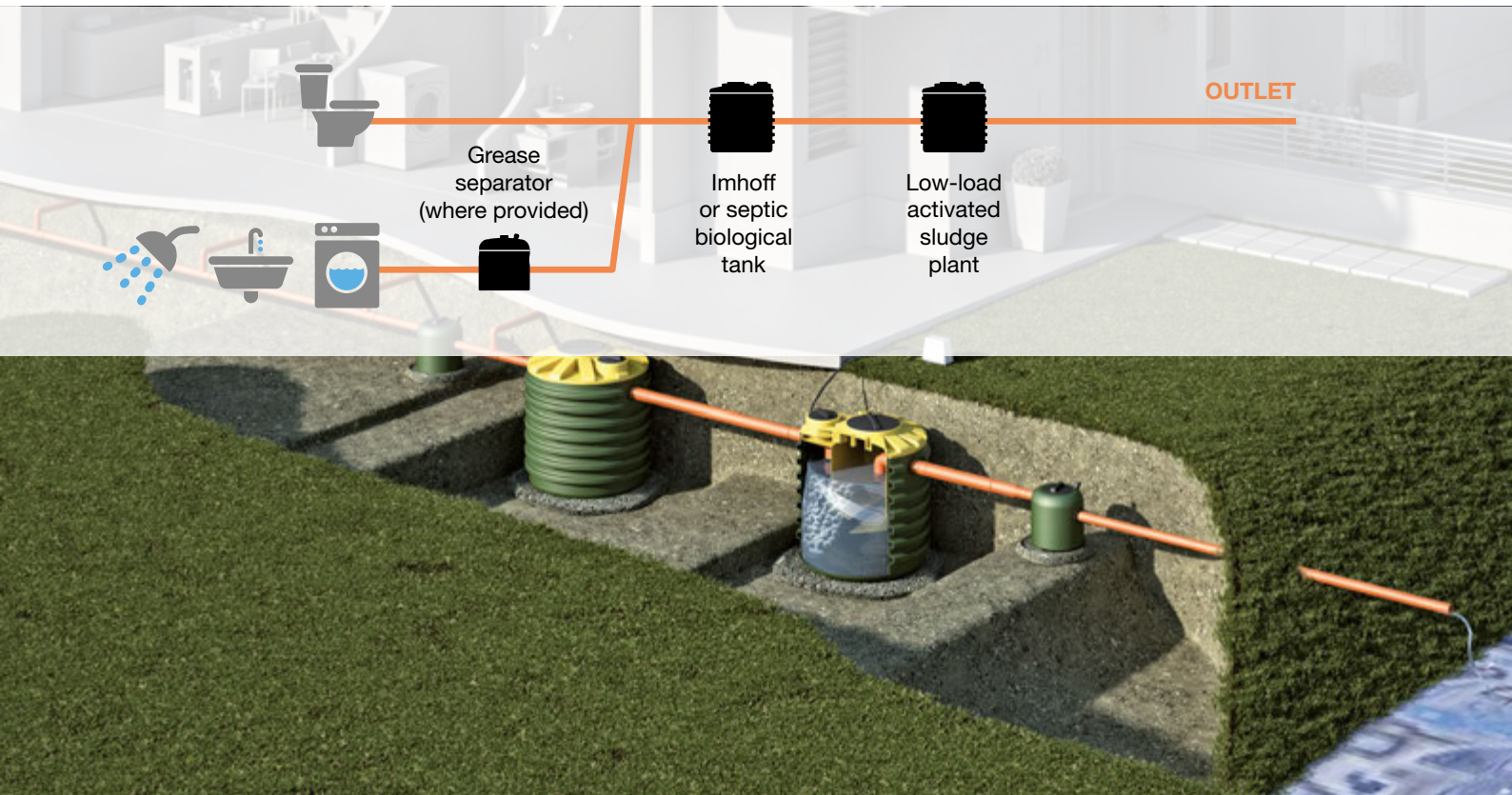

CALCULATION OF POPULATION EQUIVALENT

ACCORDING TO THE TYPE OF USER

The concept of Population Equivalent (PE) is useful for expressing the load on a treatment plant from a particular user in standard terms comparable with domestic users. The equivalence can refer to the hydraulic load, to the load in suspended solids or, more commonly, to the organic load expressed as BOD5. Population Equivalent is a conventional concept based on the mean contribution from a typical user equal to 60 g/BOD5 per inhabitant (Law Decree 152/2006). It is also particularly useful in that it allows a simple comparison to be made between the loads from very different users, expressing each user as a “population equivalent” load. The following tables indicate the operations necessary for calculating the PE’s of users that can be assimilated to a residential building.

Residential building

$$\frac{\text{Residents}}{\text{Coefficient}} \times 1 = \text{Population equivalent}$$

Charitable institutes and rest homes

$$\frac{\text{Beds}}{\text{Coefficient}} \times 2 = \text{Population equivalent}$$

Offices

$$\frac{\text{Employees}}{\text{Coefficient}} \times 0.3 = \text{Population equivalent}$$

Dance halls

$$\frac{\text{Clientele}}{\text{Coefficient}} \times 0.2 = \text{Population equivalent}$$

Restaurants

$$\frac{\text{Place settings}}{\text{Coefficient}} \times 0.3 = \text{Population equivalent}$$

Hospitals

$$\frac{\text{Beds}}{\text{Coefficient}} \times 2 = \text{Population equivalent}$$

Cafés and bars

$$\frac{\text{Clientele}}{\text{Coefficient}} \times 0.07 = \text{Population equivalent}$$

Motorway restaurants

$$\frac{\text{Seating per hour}}{\text{Coefficient}} \times 2 = \text{Population equivalent}$$

Campsites and holiday villages

$$\frac{\text{Guests and personnel}}{\text{Coefficient}} \times 0.8 = \text{Population equivalent}$$

Hotels, guest houses, holiday farms, boarding houses (guests and members of staff, excluding restaurants and bars)

$$\frac{\text{Guests and personnel}}{\text{Coefficient}} \times 1 = \text{Population equivalent}$$

Cinemas and theatres

$$\frac{\text{Seats}}{\text{Coefficient}} \times 0.13 = \text{Population equivalent}$$

Schools and educational institutes

$$\frac{\text{Students and personnel}}{\text{Coefficient}} \times 0.26 = \text{Population equivalent}$$

CERTIFICATIONS



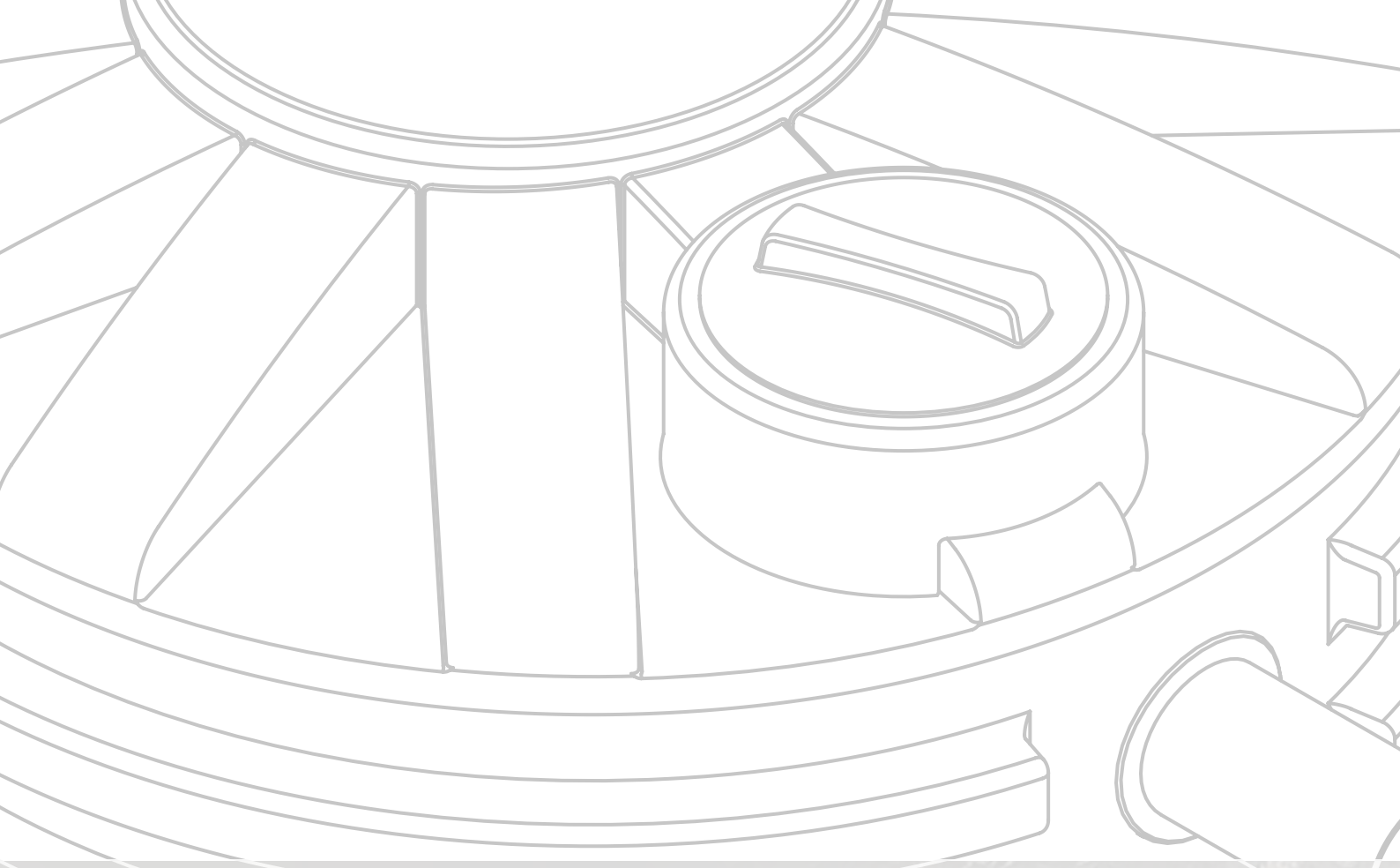



GREASE SEPARATORS



GREASE SEPARATORS

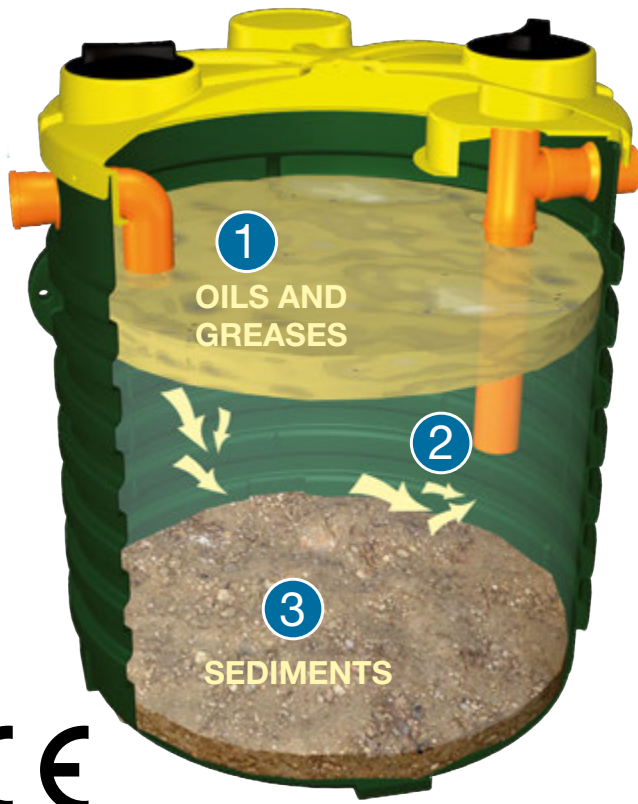

- 1 OILS AND GREASES**
inlet zone in which the turbulence of the inlet flow is dampened and in which the substances with a specific weight lower than water (oils, foams, etc...) accumulate.
- 2 STILLING AREA**
zone into which the separated and treated effluent flows.
- 3 SEDIMENTS**
area in which temporary accumulation of the solids (food waste, etc...) takes place.

INSTALLATION DIAGRAM



SPECIFICATIONS

TECHNICAL CHARACTERISTICS

The grease separator is a physical pre-treatment process that removes oils, foams, greases and all substances of specific weight less than that of the effluent.

The grease separator is nothing more than a stilling tank in which the substances of specific weight less than water are separated by floatation (surface). Sedimentation also takes place, with a part of the suspended solids depositing at the bottom of the tank.

USE

Primary treatment of grey water from kitchens, washbasins, bidets, showers, baths, washing machines and dishwashers.

PRODUCT CERTIFICATION

Rototec grease separators (with the exception of the modular range) are CE marked and are designed, tested and certified compliant with UNI EN 1825-1 "Grease separators – Part 1: Principles of design, performance and testing, marking and quality control".

The grease separators have been verified and tested at Rototec and by a third party certifying body, and have been found to comply with the necessary requirements.

- Watertightness
- Structural stability
- Determination of the nominal size
- Functional requirements
- Reaction to fire

✓
✓
✓
✓
(Class E)

CERTIFIED
UNI EN 1825-1



SEPARATION BAFFLES



GREASE SEPARATORS

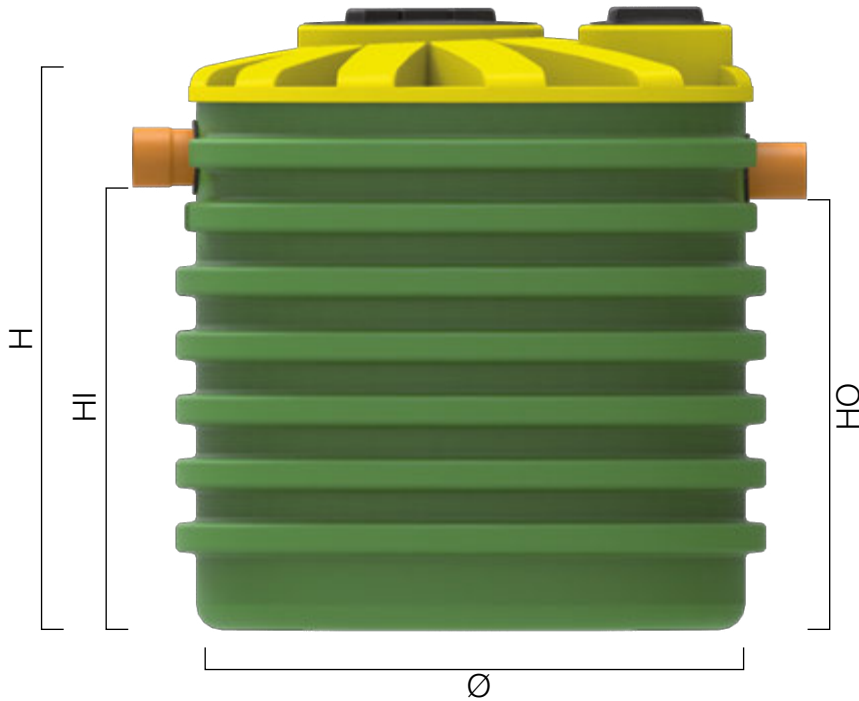

MODEL

SMOOTH



SEPARATION
BAFFLES



CORRUGATED



GREASE SEPARATORS MODULAR

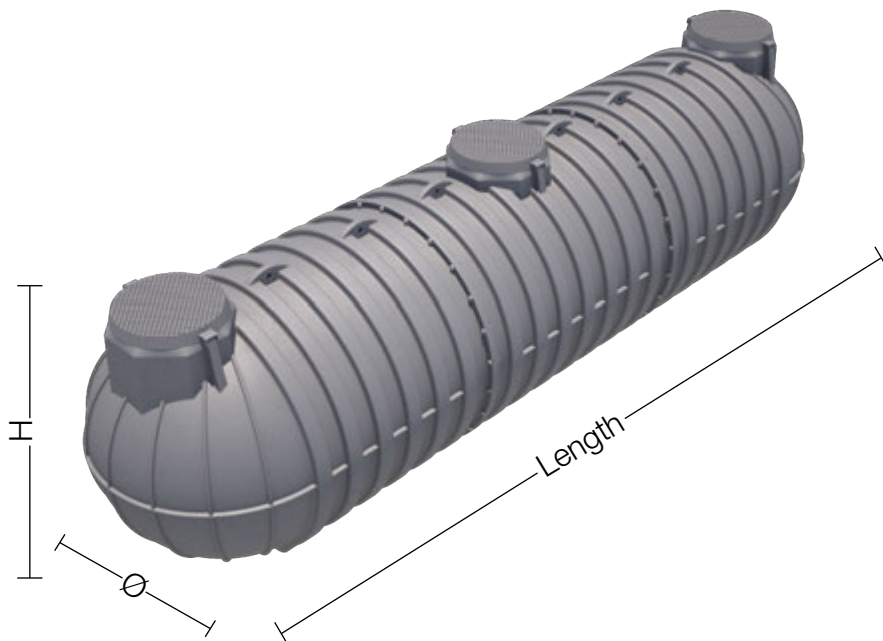







































ELIPSE



MODULAR



Item	Mod.	Length mm	Width mm	Ø mm	H mm	HI mm	HO mm	Ø I/O mm	Covers 1	Covers 2	Extension 1 (optional)	Extensions 2 (optional)	Useful Vol. l	Vol. of grease l	Vol. of sediment l	NS	PE.
DD50		-	-	430	430	270	200	100	CC300	-	PP35	-	39	5	10	0,1	1
DD150		-	-	580	660	510	440	100	CC200	-	PP30	-	121	16	32	0,3	5
NDD150		950	650	-	565	375	345	100	CC200	CC130	PM30x30G	PM20x20G	180	25	35	0,4	7
NDD200		1000	635	-	675	490	440	100	CC200	CC130	PM30x30G	PM20x20G	205	30	50	0,5	10
DD300		-	-	630	970	770	700	100	CC200	-	PP30	-	218	30	59	0,5	10
NDD300		1100	700	-	775	585	535	100	CC200	CC130	PM30x30G	PM20x20G	303	40	80	0,7	15
NDD400		1150	750	-	890	695	645	100	CC200	CC130	PM30x30G	PM20x20G	409	55	110	1	20
DD500		-	-	790	790	630	560	100	CC400	CC130	PP45	-	276	32	72	0,7	15
NDD500		1400	900	-	750	560	530	100	CC200	CC130	PM30x30G	PM20x20G	510	75	140	1,2	25
NDD700		-	-	1050	1030	760	690	110	CC400	CC200	PP45	PP30	580	80	156	1,5	28
DD800		1480	630	-	1090	870	800	110	CC300	CC200	PP35	PP30	693	80	180	1,8	20
NDD1000		-	-	1150	1220	880	810	110	CC400	CC200	PP45	PP30	774	90	200	2	30
NDD1200		1900	708	-	1630	1250	1180	110	CC300	CC300	PP35	PP35	1142	120	300	3	35
NDD1250		-	-	1050	1650	1370	1300	110	CC400	CC200	PP45	PP30	1100	125	310	3	35
NDD1500		-	-	1150	1720	1360	1290	110	CC400	CC200	PP45	PP30	1193	128	320	3,1	40
NDD1700		1900	708	-	2140	1760	1690	110	CC300	CC300	PP35	PP35	1775	200	450	4	50
NDD2100		-	-	1350	1975	1540	1490	110	CC400	CC300	PP45	PP35	1850	260	550	4	60
NDD2600		-	-	1710	1450	1000	930	125	CC400	CC300	PP45	PP35	1971	220	550	5	70
NDD3200		-	-	1710	1725	1240	1170	125	CC400	CC300	PP45	PP35	2435	256	640	6,4	80
NDD3800		-	-	1710	1955	1480	1410	160	CC400	CC300	PP45	PP35	3026	330	800	7,9	90
NDD4600		-	-	1710	2225	1700	1630	160	CC400	CC300	PP45	PP35	3510	400	910	9	110
NDD5400		-	-	1950	2250	1630	1560	200	CC400	CC400	PP45	PP45	4152	462	1085	10,5	140
NDD6400		-	-	1950	2530	1940	1870	200	CC400	CC400	PP45	PP45	4862	495	1268	11,8	160
NDD7000		-	-	2250	2367	1810	1740	200	CC400	CC400	PP45	PP45	6711	900	1400	13	200
NDD9000		-	-	2250	2625	2030	1960	200	CC400	CC400	PP45	PP45	7534	1200	1800	15,5	250
ITDD11000		4420	-	2100	2200	1820	1750	200	TAP800	-	PP77	-	10135	1250	2350	23,5	285
ITDD13000		5010	-	2100	2200	1820	1750	200	TAP800	-	PP77	-	12105	1330	3020	30,0	340
ITDD15000		5620	-	2100	2200	1820	1750	200	TAP800	-	PP77	-	14150	1490	3720	37,2	400
ITDD18000		6680	-	2100	2200	1820	1750	200	TAP800	-	PP77	-	16900	1725	4320	43,0	475
ITDD20000		7270	-	2100	2200	1820	1750	200	TAP800	-	PP77	-	18610	1950	4870	48,7	540
ITDD22000		7880	-	2100	2200	1820	1750	200	TAP800	-	PP77	-	20700	2170	5450	54,5	600
ITDD25000		8940	-	2100	2200	1780	1710	250	TAP800	-	PP77	-	22800	2410	6010	60,1	640
ITDD28000		9530	-	2100	2200	1780	1710	250	TAP800	-	PP77	-	25200	2670	6620	66,1	700
ITDD30000		10140	-	2100	2200	1780	1710	250	TAP800	-	PP77	-	27250	2870	7170	71,7	800
ITDD33000		11200	-	2100	2200	1780	1710	250	TAP800	-	PP77	-	29540	3150	7710	77,2	825
ITDD35000		11790	-	2100	2200	1780	1710	250	TAP800	-	PP77	-	31710	3310	8250	82,5	885
ITDD36000		12400	-	2100	2200	1780	1710	250	TAP800	-	PP77	-	33800	3560	8890	88,9	1000
ITDD40000		13460	-	2100	2200	1780	1710	250	TAP800	-	PP77	-	36180	3820	9410	94,2	1150

Sizing: PE. = population equivalent; Ø = diameter; H = height; HI = inlet pipe height; HO = outlet pipe height; ØE/U = inlet/outlet pipe diameter; NS = limit flow rate (l/s).

ABOVE-GROUND GREASE SEPARATORS



TECHNICAL CHARACTERISTICS

the grease separator is a physical pre-treatment process that removes oils, foams, greases and all substances of specific weight less than that of the effluent.

The grease separator is nothing more than a stilling tank in which the substances of specific weight less than water are separated by floatation (upward flow to the surface). Sedimentation also takes place, with a part of the suspended solids depositing at the bottom of the tank. Its reduced width allows it to be carried through doorways. In this way, it can be installed in a suitable utility room, cellar, etc.

The above-ground grease separators are designed to be floor mounted (not buried).

USE

Treatment of grey water from kitchens, washbasins, bidets, showers, baths, washing machines and dishwashers.

REFERENCE STANDARDS

UNI EN 1825-1 Grease separators



Item: EDD1000

- 1 VENT**
polypropylene vent pipe dia. 1" 1/2
- 2 LEVEL INDICATORS**
transparent grease level indicators.
- 3 TANK DRAIN**
brass union dia. 2" with ball valve.
- 4 ODOUR-PROOF SEAL**
threaded cover with gasket for sealing odours.

Item	Length mm	Width mm	H mm	IH mm	OH mm	Ø I/O mm	Cover 1	Cover 2	Useful Vol. l	Grease vol. l	Sed. Vol. l	NS	PE	Restaurant seating
EDD500	760	760	980	720	710	75	CC300	-	400	55	125	1	12	40
EDD1000	1500	680	1450	1310	1180	75	CC300	CC300	925	125	280	2	30	100
EDD2000	2330	680	1900	1750	1610	75	CC300	CC300	1820	310	550	4	60	180

PE. = population equivalent: Ø= diameter; H= height; IH= inlet pipe height; OH= outlet pipe height; ØI/O= inlet/outlet pipe diameter; NS= limit flow rate (l/s).

UNDER-SINK GREASE SEPARATORS

Item	Length mm	Width mm	Ø mm	H mm	IH mm	OH mm	Ø I/O mm	Cover 1	Useful Vol. l	Grease vol. l	Sed. Vol. l	NS l/s
NDD25SL	360	180	-	250	-	160	-	CC130	12	3	5	0.1
DD50SL	-	-	430	430	320	290	40	CC300	39	5	10	0.1

TECHNICAL CHARACTERISTICS

The grease separator is a physical pre-treatment process that separates oils, foams, grease, heavy sediment and all substances of specific weight less than that of the effluent. The under-sink grease separator has been designed to be fitted directly under the kitchen sink of small restaurants, small beach cantinas, little bars.

USE

Primary treatment of grey water from kitchen sinks, washbasins, etc...

NDD25SL

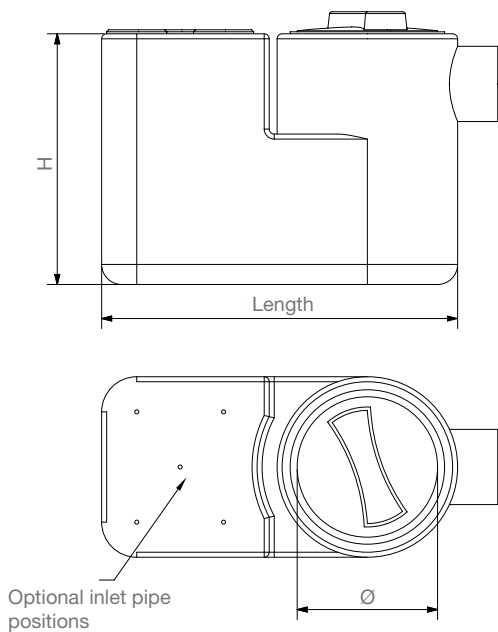

DD50SL

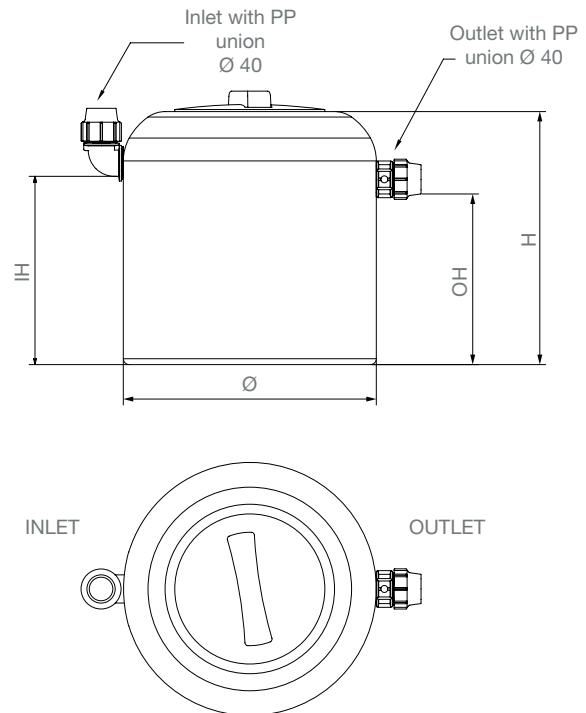

TECHNICAL SECTION - GREASE SEPARATORS

TECHNICAL CHARACTERISTICS

The grease separator is a **physical pre-treatment process** that removes oils, foams, greases and all substances of specific weight less than that of the effluent. Greases and oils produced during normal domestic activities derive from the consumption of butter, margarine, lard and vegetable oils. They also originate from waste meat and vegetables and from some cosmetic products. Greases are insoluble in water and have a low density. In the presence of surface-active agents (detergents), they create stable foams of floating materials that can cause an accumulation of putrescible substances in the sewerage pipes and render oxygenation of the sewage difficult, which also has a detrimental effect on the biological treatment processes located downstream.

The grease separator is nothing more than a **stilling tank** in which the substances of specific weight less than water are separated by floatation (surface). The reduced velocity of the fluid also allows sedimentation of a part of the suspended solids which deposit at the bottom of the tank. As temperature has a considerable influence on the operation of the grease separator, the separation process becomes 100% effective when the temperature does not rise much above the melting point of the greases, estimated as being around 20°C.

Rototec gravity grease separators consist of a polyethylene tank with two semi-submerged inlet and outlet pipes at different levels. The working volume is divided into three compartments: an inlet zone in which the turbulence of the inlet flow is dampened, a second zone in which the separation takes place together with temporary accumulation of the solids and a third outlet zone for the treated effluent. The longer the retention time of the sewage in the grease separator the more efficient is the removal of the floating materials. This retention time must nevertheless be more than 3 minutes at peak flow. **The grease separators are certified in accordance with standard UNI-EN 1825-1** (with the exception of modular, above-ground and unde-sink range) and guarantee a sewage retention time of at least 4 minutes at peak flow (Qmax), taking into account the available volume only, i.e. that not occupied by greases or heavy sediments. This guarantees retention times at mean daily flow rates of more than 15 minutes.

USE AND MAINTENANCE

The substances removed by floatation accumulate at the surface of the grease separator in the form of a surface crust, while the heavier solids settle at the bottom of the tank to form a deposit of putrescible sludge.

It is advisable to provide for the periodic removal of the accumulated materials by specialist technicians, as they reduce the effective volume required for the passage of the effluent, thus reducing the retention time and, as a result, compromising the efficiency of the plant. An excessive accumulation of sludge in the grease separator can cause septic conditions to develop, resulting in resulting bad smells, in particular during the summer.

MANAGEMENT

WHAT TO DO	WHEN	HOW
Inspect the grease separator	Every 1 / 2 months	Unscrew the covers on the inspection holes and check the level of sediment and the surface crust.
Remove the surface crust, the settled sludge and clean the inlet and outlet pipes	Every 6 / 12 months	Contact a licensed waste disposal company

N.B. the frequency of cleaning depends on the amount of oil, grease and solids in the wastewater.

PROHIBITIONS

- **do not use toxic and/or poisonous substances** (bleach, solvents, insecticides, disinfectant substances, aggressive detergents), always use biodegradable products;
- **NEVER** allow rainwater to enter the system.

WARNINGS

- make sure that drains have a siphon;
- check that the pipes have sufficient gradient (approximately 1% - 2%);
- connect the biogas vent pipe (**see underground installation**);
- in the case where grey water and sewage flow through the same pipe, **DO NOT** install the grease separator, but an Imhoff septic tank one class higher than that for the Population Equivalent (P.E.) number;
- after emptying, fill the tank again with **clean water**;
- in the event of a maintenance operation of any kind, always comply with the **safety regulations** regarding operations within enclosed wastewater treatment areas and with the general technical procedures applicable.



IMHOFF

BIOLOGICAL TANKS



DEPURO NIM

IMHOFF BIOLOGICAL TANKS

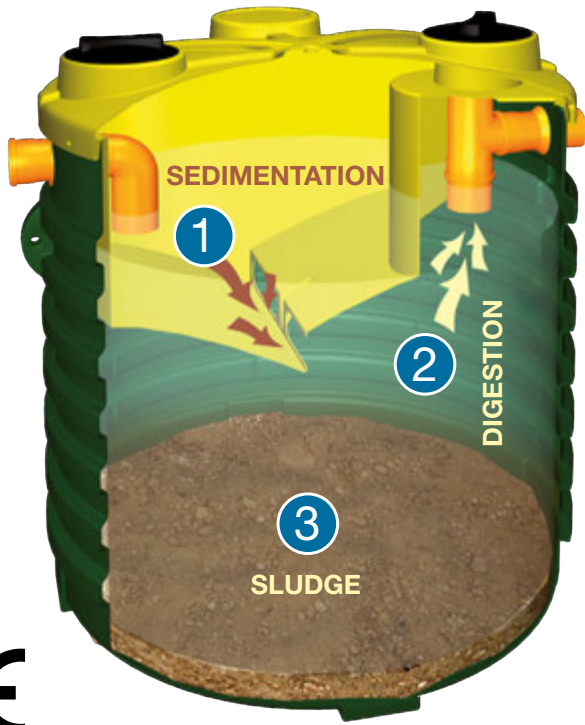

- 1 SEDIMENTATION**
sedimentation area for incoming solids.
- 2 DIGESTION**
area into which the treated effluent flows for digestion.
- 3 SLUDGE**
area in which the biological sludge responsible for purifying the effluent is formed.

CE

INSTALLATION DIAGRAM



SPECIFICATIONS

TECHNICAL CHARACTERISTICS

Imhoff type septic tanks consist of two overlapping and hydraulically communicating compartments. In the upper compartment the sedimentable solids fall to the bottom of the sedimentation chamber by gravity. The chamber is suitably inclined to allow the sludge to pass into the lower compartment where digestion takes place.

USE

Primary treatment of sewage from toilets.

DAILY HYDRAULIC LOAD: 200 l/PE

Please note: it is possible to size the treatment plant according to different daily hydraulic loads.

PRODUCT CERTIFICATION

Rototec Imhoff biological tanks are CE marked and have been designed, tested and certified under standard UNI EN 12566-3 "Small wastewater treatment systems for up to 50 PE – Part 3: Packaged and/or site assembled domestic wastewater treatment".

The tests were carried out at the PIA GmbH accredited test laboratory (Aachen - Germany). The Imhoff tanks were found to comply with the necessary requirements.

- Sewage treatment efficiency ✓
- Watertightness ✓
- Structural behaviour ✓

CERTIFIED
UNI EN 12566-3

Percentage reduction in pollutants:

64%	52%	79%
COD	BOD₅	SS



ADVANTAGES DEPURO NIM



Operating guarantee:

the tests carried out according to European standards under the control of a qualified laboratory certify the actual sewage treatment levels of the system



High sewage treatment efficiency



Wide range of models:

for homes from 2 to 40 Population Equivalent



Reduced costs of management and installation



Easy installation and maintenance:

thanks to the lightweight components



Strength:

robust, high-strength one-piece elements



Respect for the environment: polyethylene is 100% recyclable

DEPURO NIM

MODEL

CORRUGATED

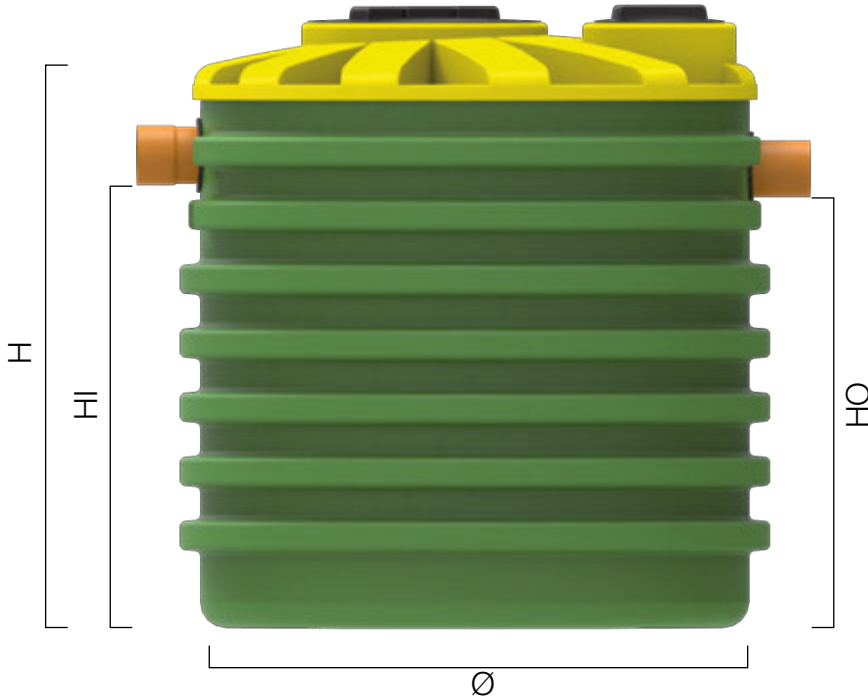

Item	Model	Ø mm	H mm	HI mm	HO mm	Ø I/O mm	Sed. Vol. l	Dig. Vol. l	Hydraulic load l/d	Organic load gBOD5/d	PE.
DEPURO02 NIM		1150	1220	880	860	110	243	607	400	120	2
DEPURO04 NIM		1150	1720	1360	1340	110	362	906	800	240	4
DEPURO07 NIM		1710	1450	1000	980	125	629	1432	1400	420	7
DEPURO10 NIM		1710	1725	1240	1220	125	760	1765	2000	600	10
DEPURO12 NIM		1710	1955	1490	1470	125	965	2139	2400	720	12
DEPURO15 NIM		1710	2225	1710	1690	125	1085	2713	3000	900	15
DEPURO20 NIM		1950	2250	1660	1640	160	1210	3137	4000	1200	20
DEPURO25 NIM		1950	2530	1970	1950	160	1322	3778	5000	1500	25
DEPURO32 NIM		2250	2367	1850	1830	160	1460	5474	6400	1920	32
DEPURO40 NIM		2250	2625	2070	2050	160	2020	5803	8000	2400	40

PE. = population equivalent: Ø = diameter; H = height; HI = inlet pipe height; HO = outlet pipe height; ØI/O = inlet/outlet pipe diameter.

IMHOFF BIOLOGICAL TANKS

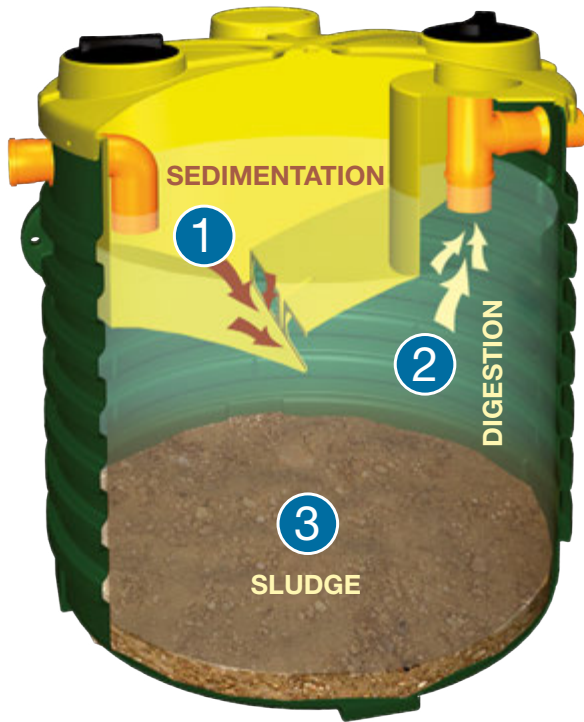

- 1 SEDIMENTATION**
sedimentation area for incoming solids.
- 2 DIGESTION**
area into which the treated effluent flows for digestion.
- 3 SLUDGE**
area in which the biological sludge responsible for purifying the effluent is formed.

INSTALLATION DIAGRAM



SPECIFICATIONS

TECHNICAL CHARACTERISTICS

Imhoff type septic tanks consist of two overlapping and hydraulically communicating compartments. In the upper compartment the sedimentable solids fall to the bottom of the sedimentation chamber by gravity. The chamber is suitably inclined to allow the sludge to pass into the lower compartment where digestion takes place.

USE

Primary treatment of sewage from toilets.

DAILY HYDRAULIC LOAD: 200 l/PE

Please note: it is possible to size the treatment plant according to different daily hydraulic loads.

IMHOFF BIOLOGICAL TANKS – MODULAR

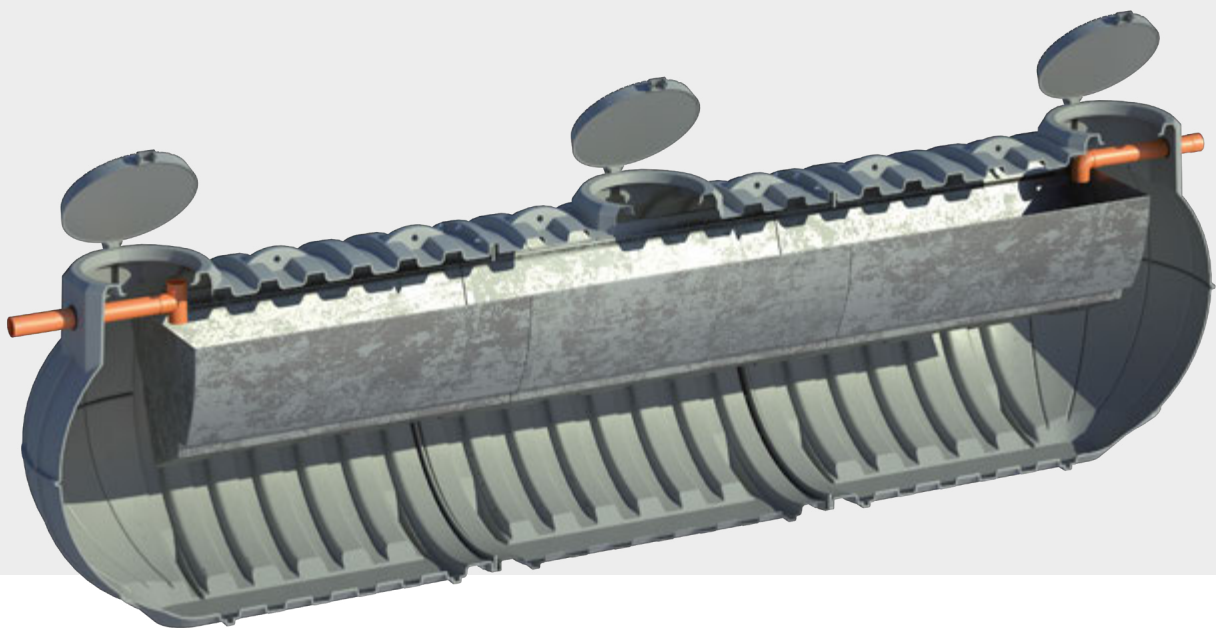

IMHOFF BIOLOGICAL TANKS

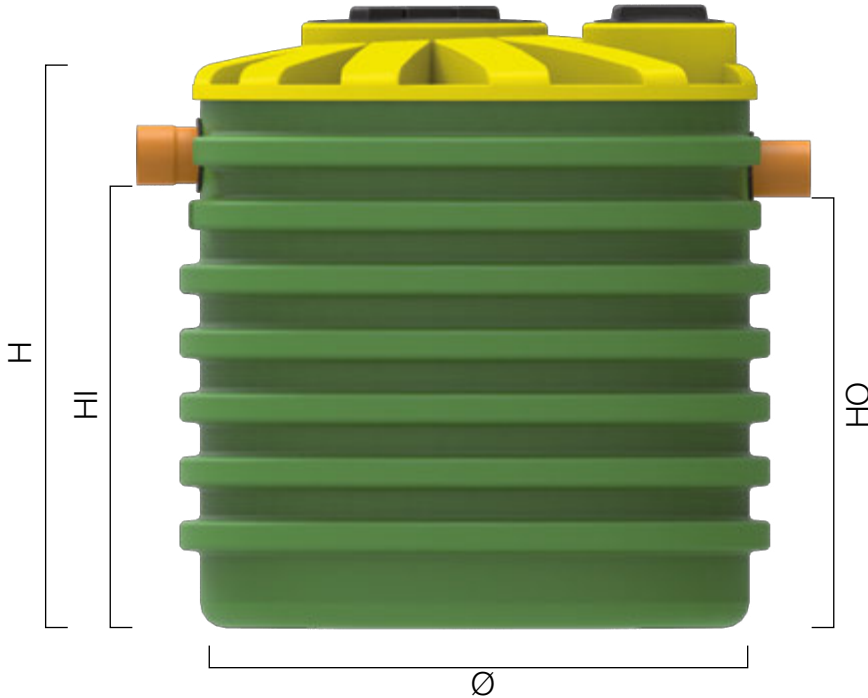

IMHOFF BIOLOGICAL TANKS MODULAR

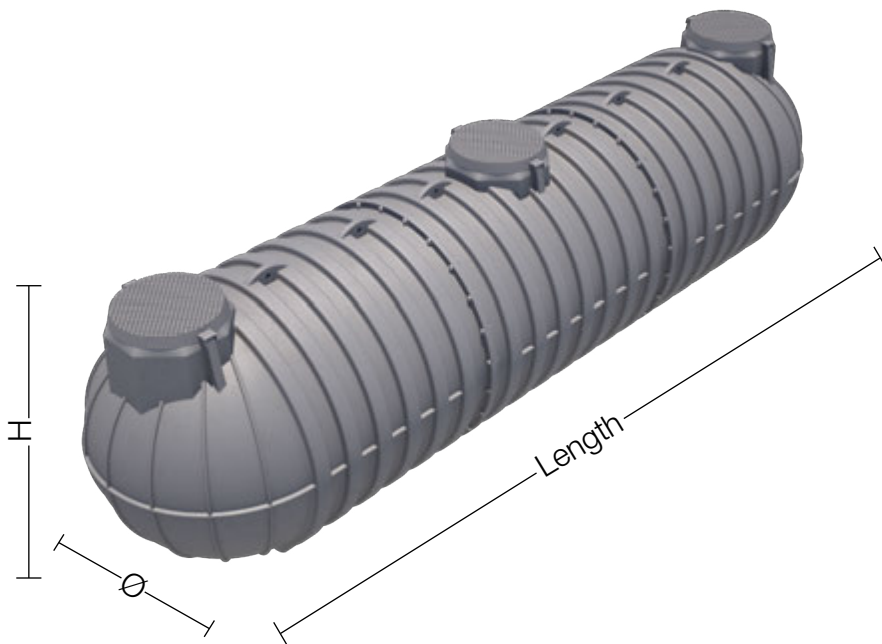

MODEL

SMOOTH



CORRUGATED



REINFORCED



ELIPSE



MODULAR



IMHOFF BIOLOGICAL TANKS

Item	Mod.	Length mm	Width mm	Ø mm	H mm	IH mm	OH mm	Ø I/O mm	Cover 1	Cover 2	Extension 1 (optional)	Extension 2 (optional)	Sed. Vol. l	Digester Vol. l	Organic load KgBOD5-d	Hydraulic load m³/d	Tot. vol. l	PE
IM500		-	-	790	790	620	600	110	CC200	CC130	PP30	-	87	218	0,18	0,6	305	3
RIM500		-	-	950	900	720	700	110	CC400	CC300	PP45	PP35RIM	75	411	0,18	0,6	486	3
NIM700		-	-	1050	1030	760	740	110	CC400	CC200	PP45	PP30	168	418	0,3	1	586	5
NIM1000		-	-	1150	1220	880	860	110	CC400	CC200	PP45	PP30	243	607	0,48	1,6	850	8
RIM1000		-	-	1160	1300	1140	1110	110	CC600	CC300	PP60RIM	PP35	190	850	0,48	1,6	1040	8
NIM1250		-	-	1050	1650	1370	1350	110	CC400	CC200	PP45	PP30	335	818	0,66	2,2	1153	11
NIM1200		1900	708	-	1630	1250	1230	110	CC300	CC300	PP35	PP35	290	910	0,72	2,4	1200	12
NIM1500		-	-	1150	1720	1360	1340	110	CC400	CC200	PP45	PP30	362	906	0,84	2,8	1268	14
RIM1500		-	-	1160	1500	1320	1300	110	CC600	CC300	PP60RIM	PP35	262	1010	0,84	2,8	1272	14
NIM1700		1900	708	-	2140	1760	1740	110	CC300	CC300	PP35	PP35	412	1363	0,96	3,2	1775	16
NIM2100		-	-	1350	1975	1540	1520	110	CC400	CC300	PP45	PP35	480	1470	1,08	3,6	1950	18
NIM2600		-	-	1710	1450	1000	980	125	CC400	CC300	PP45	PP35	629	1432	1,2	4	2061	20
NIM3200		-	-	1710	1725	1240	1220	125	CC400	CC300	PP45	PP35	760	1765	1,5	5	2525	25
NIM3800		-	-	1710	1955	1490	1470	160	CC400	CC300	PP45	PP35	965	2139	1,86	6,2	3104	31
NIM4600		-	-	1710	2225	1710	1690	160	CC400	CC300	PP45	PP35	1085	2713	2,4	8	3798	40
NIM5400		-	-	1950	2250	1660	1640	160	CC400	CC400	PP45	PP45	1210	3137	2,7	9	4347	45
NIM6400		-	-	1950	2530	1970	1950	160	CC400	CC400	PP45	PP45	1322	3778	3	10	5100	50
MTIM6000		3870	-	1550	1710	1420	1400	160	TAP800	-	PP77	-	1660	4030	3,3	11	6934	55
NIM7000		-	-	2250	2367	1850	1830	160	CC400	CC400	PP45	PP45	1460	5474	3,6	12	5690	60
NIM9000		-	-	2250	2625	2070	2050	160	CC400	CC400	PP45	PP45	2020	5803	4,8	16	7823	80
NIM9800		-	-	2270	2850	2320	2300	160	CC400	CC400	PP45	PP45	1780	7040	5,4	18	8820	90
ITIM11000		4420	-	2100	2200	1870	1840	160	TAP800	-	PP77	-	2910	7225	6	20	10135	100
MTIM12000		7180	-	1550	1710	1420	1400	160	TAP800	-	PP77	-	3240	8066	6,3	21	11306	105
ITIM13000		5010	-	2100	2200	1870	1840	160	TAP800	-	PP77	-	3495	8610	9,6	24	12105	120
ITIM15000		5620	-	2100	2200	1870	1840	160	TAP800	-	PP77	-	4070	10080	8,4	28	14150	140
MTIM18000		10510	-	1550	1710	1420	1400	160	TAP800	-	PP77	-	4880	12042	9,6	32	16842	160
ITIM18000		6680	-	2100	2200	1870	1840	160	TAP800	-	PP77	-	4820	12142	9,72	32,4	16962	162
ITIM20000		7270	-	2100	2200	1870	1840	160	TAP800	-	PP77	-	5330	13280	11,04	36,8	18610	184
ITIM22000		7880	-	2100	2200	1870	1840	160	TAP800	-	PP77	-	5860	14870	12	40	20730	200
ITIM25000		8940	-	2100	2200	1870	1840	160	TAP800	-	PP77	-	6575	16410	13,56	45,2	22985	226
ITIM28000		9530	-	2100	2200	1870	1840	160	TAP800	-	PP77	-	7240	18030	15	50	25270	250
ITIM30000		10140	-	2100	2200	1830	1800	200	TAP800	-	PP77	-	7690	19560	16,2	54	27250	270
ITIM33000		11200	-	2100	2200	1830	1800	200	TAP800	-	PP77	-	8440	21100	17,52	58,4	29540	292
ITIM35000		11790	-	2100	2200	1830	1800	200	TAP800	-	PP77	-	9040	22670	18,84	62,8	31710	314
ITIM36000		12400	-	2100	2200	1830	1800	200	TAP800	-	PP77	-	9680	24120	19,2	64	33800	320
ITIM40000		13460	-	2100	2200	1830	1800	200	TAP800	-	PP77	-	10370	25810	21,36	71,2	36180	356

PE. = population equivalent: Ø = diameter; H = height; IH = inlet pipe height; OH = outlet pipe height; ØI/O = inlet/outlet pipe diameter.

TECHNICAL SECTION - IMHOFF BIOLOGICAL TANKS

TECHNICAL CHARACTERISTICS

A series of chemical, physical and biological processes take place inside the biological septic tank, allowing a reduction in the values of the main reference parameters (BOD5, COD, SS (Suspended Solids)).

More specifically, the Imhoff cone means that the turbulence of the inlet flow is dampened in the **upper sedimentation section**, with solids tending to settle and enter the lower digestion section. In the same way, any substances with a specific weight lower than that of water (e.g. oils and greases, foam,...) separate from the effluent and accumulate on the surface. In the **digestion section**, in a **completely anaerobic environment**, the bacterial flora developed and maintained partially digests the accumulated sludge, transforming it into more stable, non-polluting products.

The Imhoff biological tank must be installed directly on the sewage line. It is good practice to install a grease separator tank for the pre-treatment of grey water from bathroom and kitchen sinks, showers, bidets, etc.

USE AND MAINTENANCE

From the moment the Imhoff is put into operation, the anaerobic bacterial flora starts to develop inside the tank. Obviously, a certain period of time is necessary in order to reach the correct balance and maximum treatment efficiency. This is known as the **start-up phase**, and can last between 2 and 5 weeks. To reduce this time, the use of a specific bio-activator is recommended.

An excessive accumulation of sedimentable material in the sludge compartment can cause **uncontrolled anaerobic digestion** phenomena, leading to an over-production of biogas and bad smells. Furthermore, the reduction in the volume available in the digestion compartment and the excessive production of gas bubbles will cause the settled material to rise, causing deterioration in the quality of the treated effluent.

The use of the Rototec BIO-ACTIVATOR is highly recommended for rendering the initiation of the biological processes more rapid, thus limiting the number of **sludge removal operations** and reducing the risk of malodorous emissions.

The DEPURO NIM Imhoff tank is designed to provide primary and secondary recirculation sludge storage for a period of 6-8 months of plant operation. A minimum of 1-2 inspections per year by qualified personnel and eventual emptying operations must be programmed according to the loads fed to the tank. Once the settled sludge has been removed, the internal surfaces of the tank must be cleaned in order to eliminate any material obstructing the effluent inlet and outlet pipes and the outlet of the sedimentation chamber.

MANAGEMENT

WHAT TO DO	WHEN	HOW
Inspect the Imhoff biological tank	From 1 to 2 times a year	Unscrew the inspection covers and check the level of sediments
Remove the settled sludge, clean the interior and the inlet and outlet pipes	Every 6 / 12 months	Contact a licensed waste disposal company

N.B. the frequency of operations will depend on the incoming organic load.

PROHIBITIONS

- **do not use toxic and/or poisonous substances** (bleach, solvents, insecticides, disinfectant substances, aggressive detergents), always use biodegradable products;
- **NEVER** flush paper tissues, kitchen towel, paper napkins or other materials except toilet paper down the toilet;
- **NEVER** allow rainwater to enter the system.

WARNINGS

- make sure that drains have a siphon;
- check that the pipes have sufficient gradient (approximately 1% - 2%);
- connect the biogas vent pipe (**see underground installation**);
- after emptying, fill the tank again with **clean water**;
- in the event of a maintenance operation of any kind, always comply with the **safety regulations** regarding operations within enclosed wastewater treatment areas and with the general technical procedures applicable within enclosed wastewater treatment areas and with the general technical procedures applicable.



BIOLOGICAL SEPTIC TANKS



BIOLOGICAL SEPTIC TANKS



- 1 STILLING AREA**
area in which the incoming effluent slows down, allowing sludge to settle and any lighter substances to separate.
- 2 SLUDGE**
the separated sludge accumulates on the bottom of the tank, and undergoes anaerobic digestion by the bacterial flora.

CE

INSTALLATION DIAGRAM



SPECIFICATIONS

TECHNICAL CHARACTERISTICS

Septic tanks constitute a reliable device for the primary treatment of sewage. The treatment systems are passive, extremely stable, simple and inexpensive. They are used, above all, for treating domestic sewage from small communities. The configuration of the tank forces the sewage to pass through the liquid mass contained in it. The slowing down of the flow allows sedimentable solids and substances of specific weight less than that of the water to separate. Furthermore, an anaerobic fermentation process is triggered with the resulting solubilisation and synthesis of part of the suspended solids. In this way, the effluent leaving the tank is conditioned, i.e. it has a limited concentration of solids, transformed for the most part into dissolved and colloidal solids.

USE

Primary treatment of domestic sewage or similar from toilets.

DAILY HYDRAULIC LOAD: 200 l/PE

Please note: it is possible to size the treatment plant according to different daily hydraulic loads

PRODUCT CERTIFICATION

Rototec biological septic tanks are CE marked and have been designed, tested and certified under standard UNI EN 12566-1 “Small wastewater treatment systems for up to 50 PT. Part 1: Prefabricated septic tanks” (excluded modular, 2-chambers and 3-chambers septic tanks).

The septic tanks have been verified and tested at Rototec and by a third party certifying body, and have been found to comply with the necessary requirements.

- Hydraulic efficiency
- Watertightness
- Nominal capacity
- Structural behaviour
- Design requirements



CERTIFIED
UNI EN 12566-1



BIOLOGICAL TANKS - MODULAR

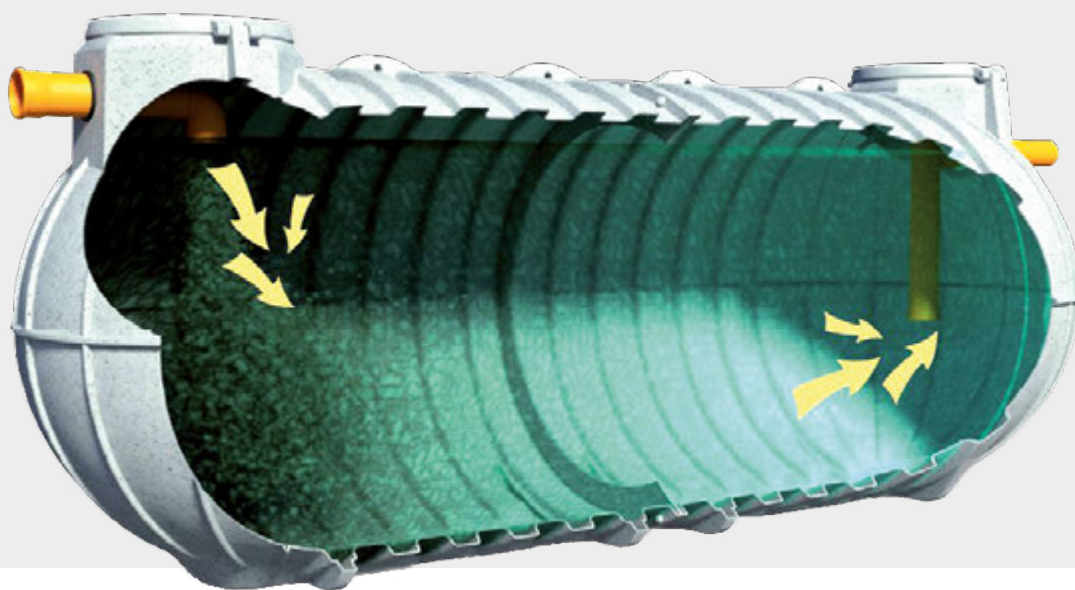

BIOLOGICAL SEPTIC TANKS

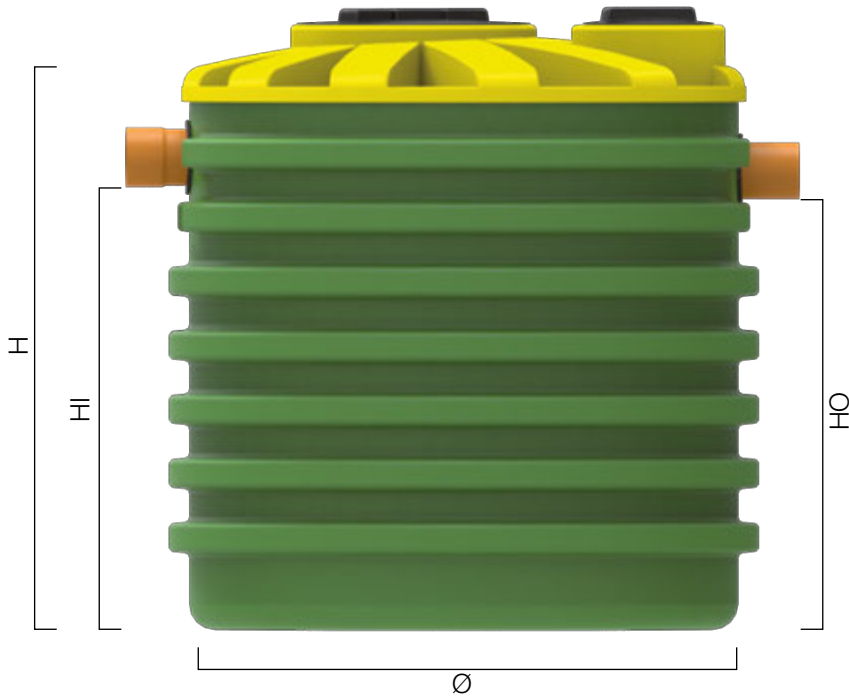

BIOLOGICAL SEPTIC TANKS MODULAR

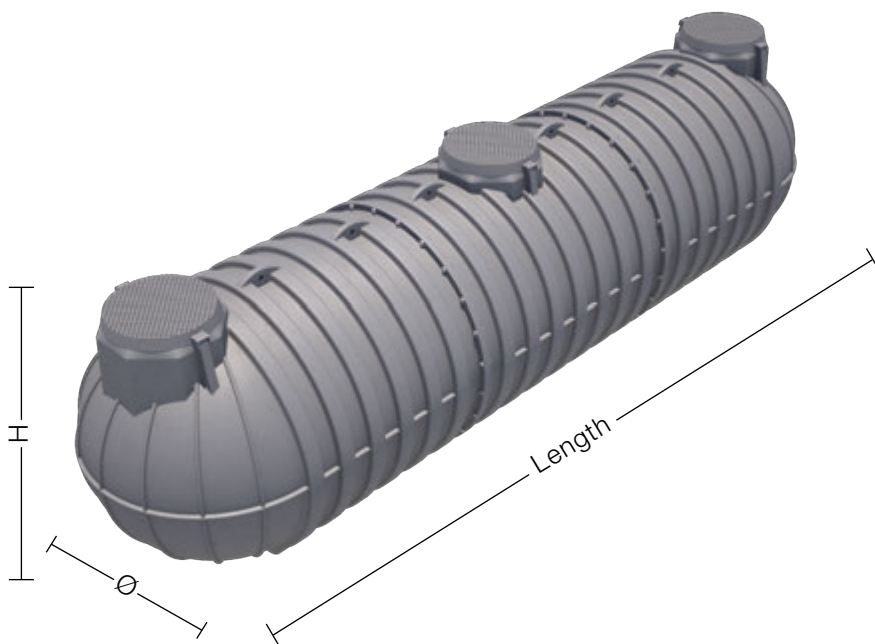

MODEL

SMOOTH



CORRUGATED































ELIPSE



MODULAR



SEPTIC TANKS - SINGLE CHAMBER

Item	Mod.	Length mm	Width mm	Ø mm	H mm	HI mm	HO mm	Ø I/O mm	Cover 1	Cover 2	Extension 1 (optional)	Extension 2 (optional)	Useful volume l	PE.
SE500		-	-	790	790	620	600	110	CC400	CC140	PP45	-	305	2
NSE700		-	-	1050	1030	760	740	110	CC400	CC200	PP45	PP30	586	4
NSE1000		-	-	1150	1220	880	860	110	CC400	CC200	PP45	PP30	850	7
NSE1200		1900	708	-	1630	1250	1230	110	CC300	CC300	PP35	PP35	1200	9
NSE1250		-	-	1050	1650	1370	1350	110	CC400	CC200	PP45	PP30	1153	9
NSE1500		-	-	1150	1720	1360	1340	110	CC400	CC200	PP45	PP30	1268	11
NSE1700		1900	708	-	2140	1760	1740	110	CC300	CC300	PP35	PP35	1775	13
NSE2100		-	-	1350	1975	1540	1520	110	CC400	CC300	PP45	PP35	1950	15
NSE2600		-	-	1710	1450	1000	980	125	CC400	CC300	PP45	PP35	2061	16
NSE3200		-	-	1710	1725	1240	1220	125	CC400	CC300	PP45	PP35	2525	20
NSE3800		-	-	1710	1955	1525	1505	125	CC400	CC300	PP45	PP35	3175	24
NSE4600		-	-	1710	2225	1745	1725	125	CC400	CC300	PP45	PP35	3835	30
NSE5400		-	-	1950	2250	1700	1680	125	CC400	CC400	PP45	PP45	4578	36
NSE6400		-	-	1950	2530	2000	1980	125	CC400	CC400	PP45	PP45	5293	42
NSE7000		-	-	2250	2367	1850	1830	160	CC400	CC400	PP45	PP45	6934	55
NSE9000		-	-	2250	2625	2070	2050	160	CC400	CC400	PP45	PP45	7823	70
ITSE11000		4420	-	2100	2200	1870	1850	160	TAP800	-	PP77	-	10135	100
ITSE13000		5010	-	2100	2200	1870	1850	160	TAP800	-	PP77	-	12105	120
ITSE15000		5620	-	2100	2200	1870	1850	160	TAP800	-	PP77	-	14150	140
ITSE18000		6680	-	2100	2200	1870	1850	160	TAP800	-	PP77	-	16900	165
ITSE20000		7270	-	2100	2200	1850	1830	200	TAP800	-	PP77	-	18610	185
ITSE22000		7880	-	2100	2200	1850	1830	200	TAP800	-	PP77	-	20700	200
ITSE25000		8940	-	2100	2200	1850	1830	200	TAP800	-	PP77	-	22800	225
ITSE28000		9530	-	2100	2200	1850	1830	200	TAP800	-	PP77	-	25200	250
ITSE30000		10140	-	2100	2200	1820	1800	250	TAP800	-	PP77	-	27250	270
ITSE33000		11200	-	2100	2200	1820	1800	250	TAP800	-	PP77	-	29540	290
ITSE35000		11790	-	2100	2200	1820	1800	250	TAP800	-	PP77	-	31710	310
ITSE36000		12400	-	2100	2200	1820	1800	250	TAP800	-	PP77	-	33800	330
ITSE40000		13460	-	2100	2200	1820	1800	250	TAP800	-	PP77	-	36180	360

PE. = population equivalent: Ø = diameter; H = height; HI = inlet pipe height; HO = outlet pipe height; ØI/O = inlet/outlet pipe diameter.

SEPTIC TANKS 2 CHAMBERS

Item	Mod.	Length mm	Width mm	Ø mm	H mm	HI mm	HO mm	Ø I/O mm	Covers 1	Covers 2	Extension 1 (optional)	Extensions 2 (optional)	Useful Vol. l	PE.
SEB500X2		-	-	790	790	620	600	110	CC400	CC140	PP45	-	610	4
NSEB700X2		-	-	1050	1030	760	740	110	CC400	CC200	PP45	PP30	1172	8
NSEB1000X2		-	-	1150	1220	880	860	110	CC400	CC200	PP45	PP30	1700	14
NSEB1200X2		1900	708	-	1630	1250	1230	110	CC300	CC300	PP35	PP35	2400	18
NSEB1250X2		-	-	1050	1650	1370	1350	110	CC400	CC200	PP45	PP30	2306	18
NSEB1500X2		-	-	1150	1720	1360	1340	110	CC400	CC200	PP45	PP30	2536	22
NSEB1700X2		1900	708	-	2140	1760	1740	110	CC300	CC300	PP35	PP35	3550	26
NSEB2100X2		-	-	1350	1975	1540	1520	110	CC400	CC300	PP45	PP35	3900	30
NSEB2600X2		-	-	1710	1450	1000	980	125	CC400	CC300	PP45	PP35	4122	32
NSEB3200X2		-	-	1710	1725	1240	1220	125	CC400	CC300	PP45	PP35	5050	40
NSEB3800X2		-	-	1710	1955	1525	1505	125	CC400	CC300	PP45	PP35	6350	48
NSEB4600X2		-	-	1710	2225	1745	1725	125	CC400	CC300	PP45	PP35	7670	60
NSEB5400X2		-	-	1950	2250	1700	1680	125	CC400	CC400	PP45	PP45	9156	72
NSEB6400X2		-	-	1950	2530	2000	1980	125	CC400	CC400	PP45	PP45	10586	84
NSEB7000X2		-	-	2250	2367	1850	1830	160	CC400	CC400	PP45	PP45	13868	110
NSEB9000X2		-	-	2250	2625	2070	2050	160	CC400	CC400	PP45	PP45	15646	140

SEPTIC TANKS 3 CHAMBERS

Item	Mod.	Length mm	Width mm	Ø mm	H mm	HI mm	HO mm	Ø I/O mm	Covers 1	Covers 2	Extension 1 (optional)	Extensions 2 (optional)	Useful Vol. l	PE.
SET500X3		-	-	790	790	620	600	110	CC400	CC140	PP45	-	915	6
NSET700X3		-	-	1050	1030	760	740	110	CC400	CC200	PP45	PP30	1761	12
NSET1000X3		-	-	1150	1220	880	860	110	CC400	CC200	PP45	PP30	2550	21
NSET1200X3		1900	708	-	1630	1250	1230	110	CC300	CC300	PP35	PP35	3600	27
NSET1250X3		-	-	1050	1650	1370	1350	110	CC400	CC200	PP45	PP30	3459	27
NSET1500X3		-	-	1150	1720	1360	1340	110	CC400	CC200	PP45	PP30	3804	33
NSET1700X3		1900	708	-	2140	1760	1740	110	CC300	CC300	PP35	PP35	5325	39
NSET2100X3		-	-	1350	1975	1540	1520	110	CC400	CC300	PP45	PP35	5550	45
NSET2600X3		-	-	1710	1450	1000	980	125	CC400	CC300	PP45	PP35	6183	48
NSET3200X3		-	-	1710	1725	1240	1220	125	CC400	CC300	PP45	PP35	7575	60
NSET3800X3		-	-	1710	1955	1525	1505	125	CC400	CC300	PP45	PP35	9525	72
NSET4600X3		-	-	1710	2225	1745	1725	125	CC400	CC300	PP45	PP35	11505	90
NSET5400X3		-	-	1950	2250	1700	1680	125	CC400	CC400	PP45	PP45	13734	108
NSET6400X3		-	-	1950	2530	2000	1980	125	CC400	CC400	PP45	PP45	15879	126
NSET7000X3		-	-	2250	2367	1850	1830	160	CC400	CC400	PP45	PP45	20802	165
NSET9000X3		-	-	2250	2625	2070	2050	160	CC400	CC400	PP45	PP45	23619	210

TECHNICAL SECTION - SEPTIC TANKS

TECHNICAL CHARACTERISTICS

Septic tanks constitute a reliable device for the primary treatment of sewage. The treatment systems are passive, extremely stable, simple and inexpensive. They are used, above all, for treating domestic sewage from small communities. The configuration of the tank forces the sewage to pass through the liquid mass contained in it. The slowing down of the flow allows sedimentable solids and substances of specific weight less than that of the water to separate. Furthermore, an anaerobic fermentation process is triggered with the resulting **solubilisation and synthesis of part of the suspended solids**. In this way, the effluent leaving the tank is conditioned, i.e. it has a limited concentration of solids, transformed for the most part into dissolved and colloidal solids.

Septic tanks are nothing more than **stilling tanks** in which the following processes take place:

- **separation** of sedimentable solids, coarse material, sands/grits, oils and greases present in the sewage;
- reduction of a fraction of the accumulated organic substances by **decomposition**;
- accumulation and prolonged **storage** of the separated materials.

Compartmentation, i.e. the division of the system into chambers, significantly influences the efficiency of the treatment process. With this configuration, a large part of the suspended solids accumulate in the first compartment and only pass to the next chamber with great difficulty. Compartmentation is particularly effective when high levels of treatment are to be reached, particularly in terms of reducing suspended solids. Septic tanks are sized to achieve a high purification performance and to obtain liquefaction of the sludge, reducing its formation and thus minimising disposal costs. **The septic tanks are certified under standard UNI EN 12566-1** (excluded modular, 2-chambers and 3-chambers septic tanks).

USE AND MAINTENANCE

An excessive accumulation of putrescible material at the bottom of the tank can cause **uncontrolled anaerobic digestion** phenomena, leading to an over-production of biogas and the development of malodorous emissions. Furthermore, the reduction in the volume available in the digestion compartment and the excessive production of gas bubbles will cause the settled material to rise, thus causing **deterioration** in the quality of the treated effluent.

For this reason, according to the loads feeding the tank, between 1 and 4 inspections a year are to be carried out, with removal of the sludge if necessary. It is sometimes recommended not to remove all the deposited sludge, but to **leave approximately 1/10 of the sludge** that has deposited in the tank; this accelerates re-start of the processes. The use of the Rototec Bio-activator is highly recommended to trigger the biological processes more quickly, thus limiting the number of sludge removal operations and reducing the risk of bad smells.

MANAGEMENT

WHAT TO DO	WHEN	HOW
Inspect the septic tank	From 1 to 4 times a year	Unscrew the inspection covers and check the level of sediments
Remove the settled sludge, clean the interior and the inlet and outlet pipes	Every 6 / 12 months	Contact a licensed waste disposal company

N.B. the frequency of operations will depend on the incoming organic load.

PROHIBITIONS

- **do not use toxic and/or poisonous substances** (bleach, solvents, insecticides, disinfectant substances, aggressive detergents), always use biodegradable products;
- **NEVER** flush paper tissues, kitchen towel, paper napkins or other materials except toilet paper down the toilet;
- **NEVER** allow rainwater to enter the system.

WARNINGS

- make sure that drains have a siphon;
- check that the pipes slope sufficiently (approximately 1% - 2%);
- connect the biogas vent pipe (**see underground installation**);
- after emptying, fill the tank again with **clean water**;
- in the event of a maintenance operation of any kind, always comply with the **safety regulations** regarding operations within enclosed wastewater treatment areas and with the general technical procedures applicable.
- make sure that drains have a siphon;



SEWAGE TREATMENT PLANTS - DEPURO



DEPURO ONE

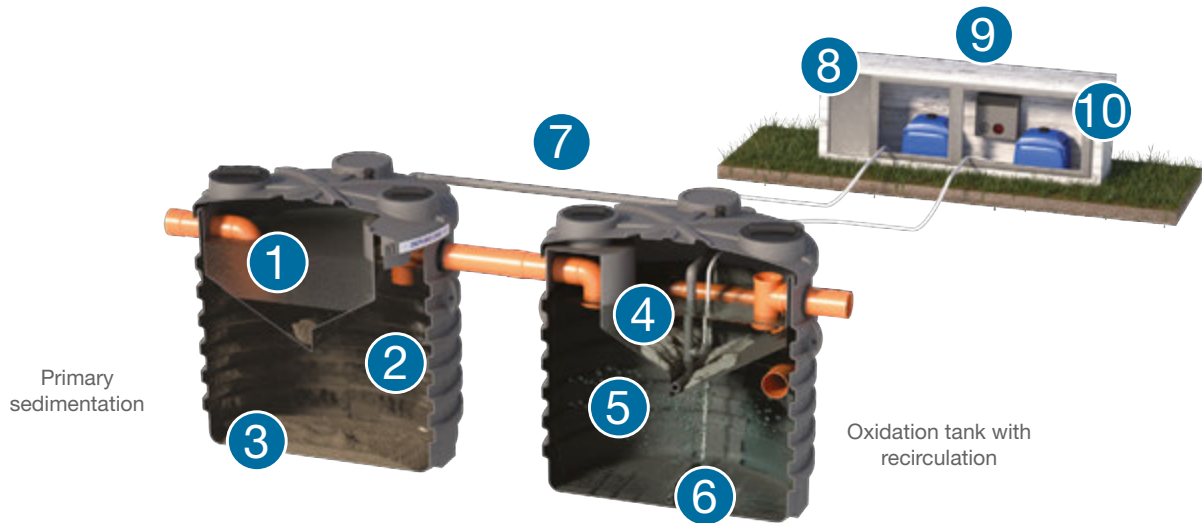

- 1 SEDIMENTATION**
sedimentation area for incoming solids.
- 2 DIGESTION**
area into which the treated effluent flows for digestion.
- 3 SLUDGE**
area in which the biological sludge responsible for purifying the effluent is formed.
- 4 SEDIMENTATION AREA**
stilling area in which the residual sludge sediments and returns once again to the primary sedimentation tank.
- 5 OXYGENATION AREA**
area in which the effluent is mixed and oxygenated, thanks to air diffuser plates. This develops aerobic bacteria that transform the biodegradable compounds into CO₂, organic nitrogen into ammonia and ammonia into nitrates.
- 6 PIPE DIFFUSERS**
micro-bubble air diffusers, included
- 7 SLUDGE RETURN**
air-lift system to return the sludge that has settled in the primary sedimentation tank.
- 8 RECIRCULATION BLOWER**
included.
- 9 ELECTRIC PANEL**
serving the blowers. Fitted with timer and an audible/visual alarm (included).
- 10 OXYGENATION BLOWER**
used to blow air into the oxygenation area through the diffusers. Included.

INSTALLATION DIAGRAM

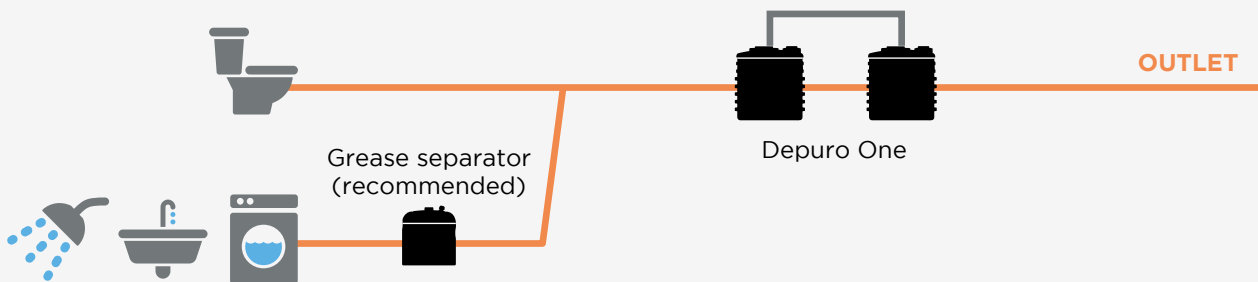

SPECIFICATIONS

TECHNICAL CHARACTERISTICS

DEPURO ONE is a fully biological treatment system for domestic effluent and the like. It consists of two tanks: a primary tank for separation, digestion and sludge accumulation (primary sedimentation tank) and an oxydation tank with recirculation to oxidise the pollutants present in the effluent. Both tanks are made of polyethylene (PE) manufactured using rotational moulding technology.

USE

Primary and secondary treatment of domestic and assimilable sewage.

DAILY HYDRAULIC LOAD: 200 l/PE

Please note: it is possible to size the treatment plant according to different daily hydraulic loads.

PRODUCT CERTIFICATION

Rototec DEPURO ONE systems are CE marked and have been designed, tested and certified under standard UNI EN 12566-3 "Small wastewater treatment systems for up to 50 PT — Part 3: Packaged and/or site assembled domestic wastewater treatment".

The tests were carried out at the PIA Gmbh accredited test laboratory (Aachen - Germany). DEPURO ONE systems were found to comply with the necessary requirements.

- Sewage treatment efficiency
- Watertightness
- Structural behaviour



CERTIFIED
UNI EN 12566-3

Percentage reduction in pollutants:

84%	87%	92%	27%
COD	BOD₅	SS	N_{tot}



ADVANTAGES DEPURO ONE



Operating guarantee:

the tests carried out according to European standards under the control of a qualified laboratory certify the actual sewage treatment levels of the system



High sewage treatment efficiency



Wide range of models:

for homes from 2 to 40 Population Equivalent



Reduced costs of management and installation



Easy installation and maintenance:

thanks to the lightweight components



Strength:

robust, high-strength one-piece elements



Respect for the environment: polyethylene is 100% recyclable

DEPURO ONE

MODEL

CORRUGATED

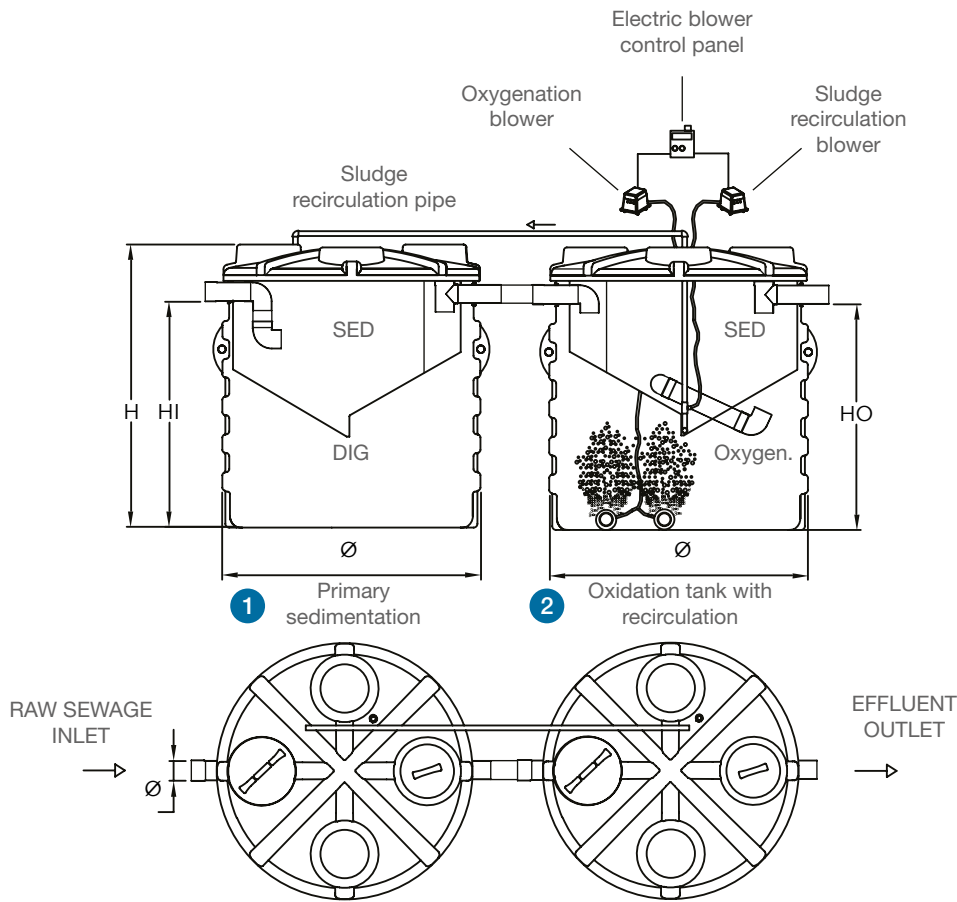

Item	Model	Ø mm	H mm	HI mm	HO mm	Ø Pipes mm	TANK 1		TANK 2		Hydraulic load l/d	Organic load gBOD ₅ /d	Blower power W	PE.
							Sed. vol. l	Dig. vol. l	Oxyg. vol. l	Final sed. vol. l				
DEPURO 02ONE		1150	1220	880	860	110	243	607	607	243	400	120	61+31	2
DEPURO 04ONE		1150	1720	1360	1340	110	362	906	906	362	800	240	61+31	4
DEPURO 07ONE		1710	1450	1000	980	125	629	1432	1432	629	1400	420	91+31	7
DEPURO 10ONE		1710	1725	1240	1220	125	780	1765	1765	780	2000	600	91+31	10
DEPURO 12ONE		1710	1955	1490	1470	125	965	2139	2139	965	2400	720	91+61	12
DEPURO 15ONE		1710	2225	1710	1690	125	1085	2713	2713	1085	3000	900	152+61	15
DEPURO 20ONE		1950	2250	1680	1640	160	1210	3137	3137	1210	4000	1200	152+61	20
DEPURO 25ONE		1950	2530	1970	1950	160	1322	3778	3778	1322	5000	1500	152+61	25
DEPURO 32ONE		2250	2367	1850	1830	160	1460	5474	5474	1460	6400	1920	186+91	32
DEPURO 40ONE		2250	2625	2070	2050	160	2020	5803	5803	2020	8000	2400	186+91	40

PE. = population equivalent: Ø = diameter; H = height; HI = inlet pipe height; HO = outlet pipe height.

TECHNICAL SECTION - DEPURO ONE

TECHNICAL CHARACTERISTICS

A number of both anaerobic and aerobic biological processes take place within the **DEPURO ONE** treatment plant, creating different species of bacterial that do or do not use oxygen to oxidise the organic substrate. For this reason, the nitrogenous compounds present in the effluent are oxidised (in an aerobic environment) or reduced (in an anaerobic environment), transforming into more simple, non-polluting compounds such as molecular nitrogen (N₂). The system consists of 2 elements:

TANK 1: this is a true Imhoff type **biological tank**, consisting of two overlapping and hydraulically communicating compartments. In the upper compartment the sedimentable solids drop to the bottom of the sedimentation chamber by gravity. The chamber is suitably inclined to allow the sludge to pass into the lower compartment. Here the sludge accumulates and is partially digested by **anaerobic bacterial micro flora** which develops and remains active. In the same way, the components with a specific weight lower than that of water (e.g. oils and greases, foam,...) separate from the effluent and accumulate in the upper compartment of the tank. The surplus sludge recirculated by the oxidation tank installed downstream also accumulate in this first tank. The physical process of gravity separation, combined with the cold anaerobic digestion processes that take place in this first tank, result in an **over 50% reduction** of the solid and organic component in the effluent itself.

TANK 2: this is also divided into two sections: the lower, and larger, section provides for **oxygenation of the effluent**, whereas the (successive) upper section is a **stilling area** in which the residual surplus sludge separates from the effluent, accumulates on the bottom of the tank, and are returned to the first tank via an air-lift type recirculation system. The oxygen required to develop the aerobic reactions is made available in dissolved form through dissolution in the liquid of the oxygen present in the atmosphere, by means of energetic artificial aeration using suitable **blowers/compressors** and **micro-bubble air diffusers**, located on the bottom of the tank. Complex phenomena are set up in the oxygen-rich environment of the aeration compartment. These are chemical (chemical oxidation of the malodorous substances), physical (the jelly-like flakes of activated sludge trap any solids that may have escaped primary treatment) and above all biological (the micro-organisms use the dissolved organic substances to develop, transforming them into a living substance that can be separated from the water by sedimentation) . The two blowers/compressors (the oxygenation blower and the one feeding the recirculation system) are low-energy diaphragm compressors equipped with a **control panel with digital timer** to optimise the system on/off timing. This control panel also has a **buzzer** and a **visual alarm** to indicate any malfunctions in the **compressors**.

USE AND MAINTENANCE

TANK 1: an excessive accumulation of sedimentable material in the sludge compartment can cause **uncontrolled anaerobic digestion** phenomena, leading to an over-production of biogas and malodorous emissions. Furthermore, the reduction in the volume available in the digestion compartment and the excessive production of gas bubbles will cause the settled material to rise, thus causing deterioration in the quality of the treated effluent.

The use of the Rototec BIO-ACTIVATOR is highly recommended for rendering the initiation of the biological processes more rapid, thus limiting the number of **sludge removal operations** and reducing the risk of malodorous emissions.

The Imhoff tank is designed to provide primary and secondary recirculation sludge storage for a period of 6-8 months of plant operation. A minimum of 1-2 inspections per year by qualified personnel and eventual emptying operations must be programmed according to the loads fed to the tank. Once the settled sludge has been removed, the internal surfaces of the tank must be cleaned in order to eliminate any material obstructing the effluent inlet and outlet pipes and the outlet of the sedimentation chamber.

TANK 2: check the sedimentation section periodically to see whether there are areas of **sludge build-up**. In the same way, also check the characteristics of the effluent in the oxygenation section. The effluent must be rather clear, with suspended flakes (activated sludge) that are clearly defined and **light brown in colour**. If there is an excessive build-up of sludge in the sedimentation chamber and the effluent is excessively turbid with dark, stringy flakes, the sludge must be extracted. Like the primary sedimentation tank, the oxidation tank normally requires cleaning and pumping out every 6-8 months. Activation of the oxidation tank and formation of the flakes of sludge requires an initial period of 2-3 weeks. The activation processes can be optimised and speeded up by using the Rototec BIO-ACTIVATOR specific for aerobic treatment plants. months of plant operation. A minimum of 1-2 inspections per year by qualified personnel and eventual emptying operations must be programmed according to the loads fed to the tank. Once the settled sludge has been removed, the internal surfaces of the tank must be cleaned in order to eliminate any material obstructing the effluent inlet and outlet pipes and the outlet of the sedimentation chamber.

TECHNICAL SECTION - DEPURO ONE

MANAGEMENT

WHAT TO DO	WHEN	HOW
Inspect the primary sedimentation	From 1 to 2 times a year	Unscrew the covers on the inspection holes and check the level of sediments
Extract the bottom sludge, clean the interior and the inlet and outlet pipes	Every 6 / 12 months	Contact a licensed waste disposal company
Inspect the oxydation tank	Every 6 / 12 months	Unscrew the covers on the inspection holes and check the level of sediments
Extract the bottom sludge, clean the internal walls and the inlet and outlet pipes	Every 6 / 12 months	Contact a licensed waste disposal company
Clean the pipe diffuser in the oxydation tank	Every 6 / 12 months	Contact a licensed waste disposal company (water jet pump-out)
Check that the blower in the oxydation tank is working properly	Every month	Unfasten the cover on the inlet inspection hole and check that air is being blown into the oxydation tank
Check that the recirculation blower is working properly	Every month	Unfasten the cover on the oxydation tank inlet and check sludge recirculation

N.B. the frequency of cleaning depends on the amount of oil, grease and solids in the wastewater.

PROHIBITIONS

- **do not use toxic and/or poisonous substances** (bleach, solvents, insecticides, disinfectant substances, aggressive detergents); always use biodegradable products;
- **NEVER** flush paper tissues, kitchen towel, paper napkins or other materials except toilet paper down the toilet;
- **NEVER** drain rainwater into the system.

WARNINGS

- make sure that drains have a siphon;
- check that the pipes slope sufficiently (approximately 1% - 2%);
- connect the biogas vent pipe in both tanks (**see underground installation**);
- after pump-out, fill the tanks again with **clean water**;
- in the event of a maintenance operation of any kind, always comply with the **safety regulations** regarding operations within closed wastewater treatment areas, and with the general technical procedures applicable within enclosed wastewater treatment areas and with the general technical procedures applicable.

DEPURO PLUS⁺

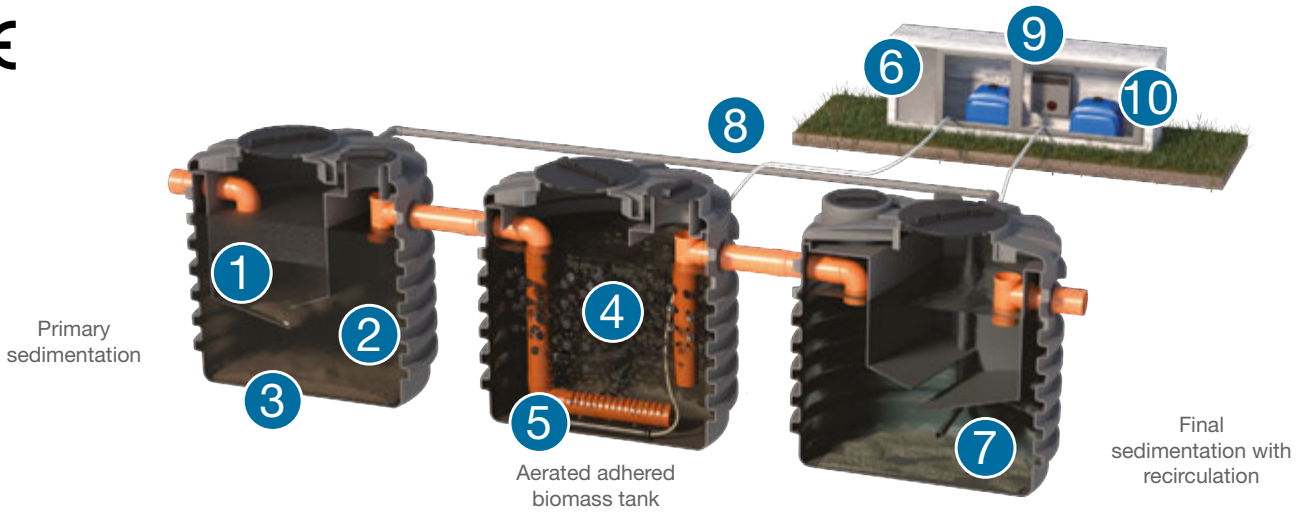

1 SEDIMENTATION

sedimentation area for incoming solids.

2 DIGESTION

area into which the treated effluent flows for digestion.

3 SLUDGE

area in which the biological sludge responsible for treatment of the effluent is formed.

4 FILTER MEDIA

plastic filter media with a large surface area (> 450 m²/m³) that act as a support on which the aerobic bacterial that treat the effluent can develop.

5 PIPE DIFFUSERS

micro-bubble air diffusers, included

6 OXYGENATION BLOWER

used to blow air into the treatment plant through the diffusers. Included.

7 FINAL SEDIMENTATION

stilling tank in which the surplus sludge sediments and returns once again to the primary sedimentation section.

8 SLUDGE RETURN

air-lift system to return the sludge that has settled in the primary sedimentation tank.

9 ELECTRIC PANEL

serving the blowers. Fitted with timer and buzzer/visual alarm (included).

10 RECIRCULATION BLOWER

included.

INSTALLATION DIAGRAM

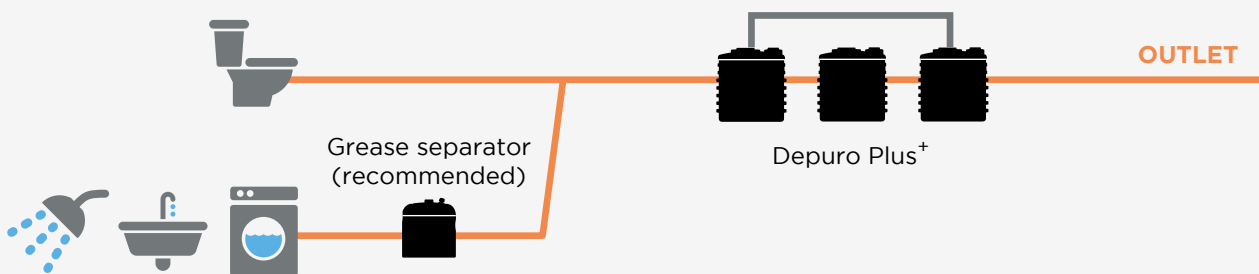

SPECIFICATIONS

TECHNICAL CHARACTERISTICS

DEPURO PLUS is a fully biological treatment system for domestic effluent and the like. It consists of three tanks: a primary tank for separation, digestion and sludge accumulation (primary sedimentation tank), an aerated adhered biomass treatment tank to oxidise the pollutants present in the effluent and a final sedimentation tank for the separation of the surplus sludge and the recirculation of it. All the tanks are made of polyethylene (PE) manufactured using rotational moulding technology.

USE

Primary and secondary treatment of domestic and assimilable sewage.

DAILY HYDRAULIC LOAD: 200 l/PE

Please note: it is possible to size the treatment plant according to different daily hydraulic loads.

PRODUCT CERTIFICATION

Rototec DEPURO PLUS systems are CE marked and have been designed, tested and certified under standard UNI EN 12566-3 "Small wastewater treatment systems for up to 50 PE – Part 3: Packaged and/or site assembled domestic wastewater treatment".

The tests were carried out at the PIA GmbH accredited test laboratory (Aachen - Germany). DEPURO PLUS systems were found to comply with the necessary requirements.

- Sewage treatment efficiency
- Watertightness
- Structural behaviour



CERTIFIED
UNI EN 12566-3

Percentage reduction in pollutants:

92%	95%	96%	57%
COD	BOD₅	SS	N_{tot}



ADVANTAGES DEPURO PLUS⁺



Operating guarantee:

the tests carried out according to European standards under the control of a qualified laboratory certify the actual sewage treatment levels of the system



High sewage treatment efficiency



Wide range of models:

for homes from 3 to 45 Population Equivalent



Reduced costs of management and installation



Easy installation and maintenance:

thanks to the light-weight components



Strength:

strong, high-resistance one-piece elements



Respect for the environment:

polyethylene is 100% recyclable

DEPURO PLUS⁺

MODEL

CORRUGATED

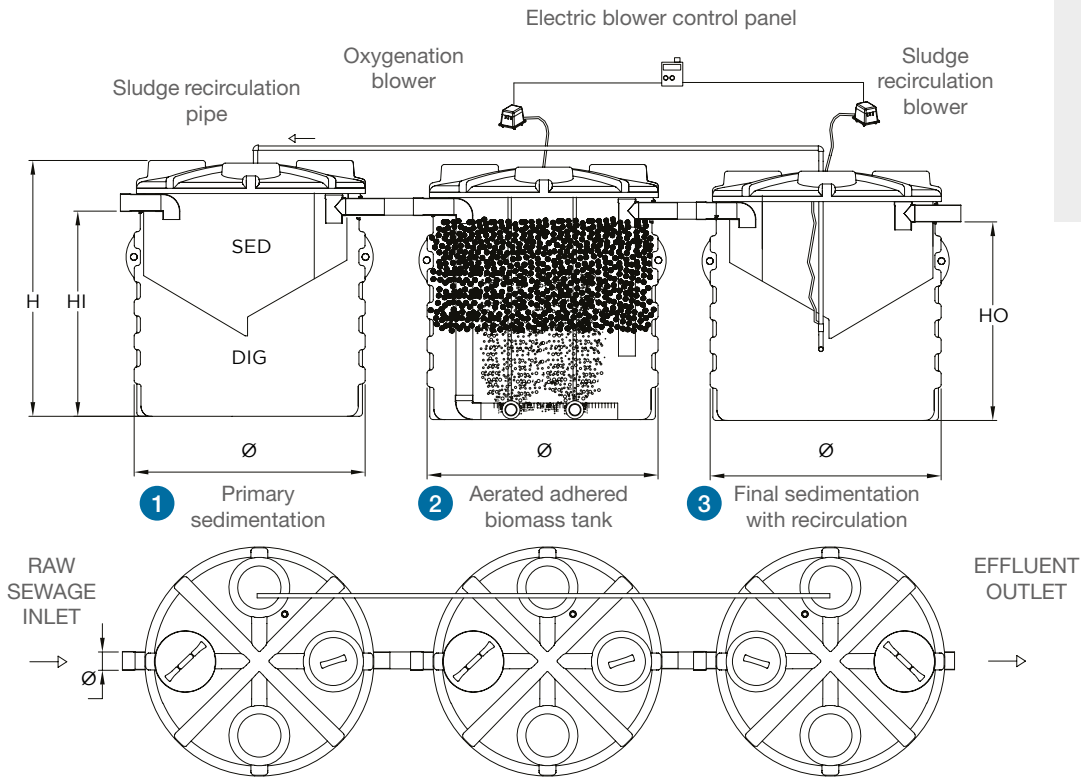

Item	Model	Ø mm	H mm	HI mm	HO mm	Ø Pipes mm	TANK 1		TANK 2	TANK 3	Hydraulic load l/d	Organic load gBOD ₅ /d	Blower power W	PE.
							Sed. vol. l	Dig. vol. l	Filter vol. l	Tot. vol. l				
DEPURO 03PLUS		1150	1220	880	860	110	243	607	607	850	600	180	61+31	3
DEPURO 05PLUS		1150	1720	1360	1340	110	362	906	906	1268	1000	300	61+31	5
DEPURO 10PLUS		1710	1450	1000	980	125	629	1432	1432	2061	2000	600	91+31	10
DEPURO 14PLUS		1710	1725	1240	1220	125	780	1765	1765	2525	2800	840	91+31	14
DEPURO 18PLUS		1710	1955	1490	1470	125	965	2139	2139	3175	3600	1080	91+61	18
DEPURO 23PLUS		1710	2225	1710	1690	125	1085	2713	2713	3835	4600	1360	152+61	23
DEPURO 28PLUS		1950	2250	1680	1640	160	1210	3137	3137	4578	5600	1680	152+61	28
DEPURO 35PLUS		1950	2530	1970	1950	160	1322	3778	3778	5293	7000	2100	152+61	35
DEPURO 40PLUS		2250	2367	1850	1830	160	1460	5474	5474	6934	8000	2400	186+91	40
DEPURO 45PLUS		2250	2625	2070	2050	160	2020	5803	5803	7823	9000	2700	186+91	45

PE. = population equivalent: Ø = diameter; H = height; HI = inlet pipe height; HO = outlet pipe height.

TECHNICAL SECTION - DEPURO PLUS⁺

TECHNICAL CHARACTERISTICS

A number of both anaerobic and aerobic biological processes take place within the **DEPURO PLUS** treatment plant, creating different species of bacteria that do or do not use oxygen to oxidise the organic substrate. For this reason, the nitrogenous compounds present in the effluent are oxidised (in an aerobic environment) or reduced (in an anaerobic environment), transforming into more simple, non-polluting compounds such as molecular nitrogen (N₂). The system consists of 3 elements:

TANK 1: this is a true Imhoff type **biological tank**, consisting of two overlapping and hydraulically communicating compartments. In the upper compartment the sedimentable solids drop to the bottom of the sedimentation chamber by gravity. The chamber is suitably inclined to allow the sludge to pass into the lower compartment. Here the sludge accumulates and is partially digested by **anaerobic bacterial micro flora** which develops and remains active. In the same way, the components with a specific weight lower than that of water (e.g. oils and greases, foam,...) separate from the effluent and accumulate in the upper compartment of the tank. The surplus sludge recirculated by the final sedimentation tank installed downstream of the adhered biomass treatment plant also accumulate in this first tank. The physical process of gravity separation, combined with the cold anaerobic digestion processes that take place in this first tank, result in an **over 50% reduction** of the solid and organic component in the effluent itself.

TANK 2: this is an **aerated adhered biomass trickle filter** in which there is a large number of plastic filter media bodies characterised by their high surface area (> 450 m²/m³). These act as a support for development of the bacterial populations that are responsible for the treatment processes. As it has a very high volume of empty space, it reduces the risk of blocking the filter bed to a minimum and also guarantees better air circulation. The filter bed, made up of filter media, is oxygenated thanks to the presence of **micro-bubble air diffusers** located on the bottom of the tank and powered by a suitable external low-energy diaphragm blower/compressor. Complex phenomena are set up in the **oxygen-rich environment**. These are chemical (chemical oxidation of the malodorous substances), physical (the jelly-like flakes of activated sludge trap any solids that may have escaped primary treatment) and above all biological (the micro-organisms that develop on the surfaces of the plastic supports use the dissolved organic substances to develop, transforming them into a living substance that can be separated from the water by sedimentation) .

TANK 3: this is a second Imhoff tank that allows separation by sedimentation of the surplus sludge coming from the biomass treatment plant. This is then returned to the first tank via an **air-lift type recirculation system** powered by a second diaphragm compressor blower.

USE AND MAINTENANCE

TANK 1: an excessive accumulation of sedimentable material in the sludge compartment can cause **uncontrolled anaerobic digestion** phenomena, leading to an over-production of biogas and malodorous emissions. Furthermore, the reduction in the volume available in the digestion compartment and the excessive production of gas bubbles will cause the settled material to rise, thus causing deterioration in the quality of the treated effluent.

The use of the Rototec BIO-ACTIVATOR is highly recommended for rendering the initiation of the biological processes more rapid, thus limiting the number of **sludge removal operations** and reducing the risk of malodorous emissions.

The primary sedimentazione tank is designed to provide primary and secondary recirculation sludge storage for a period of 6-8 months of plant operation. A minimum of 1-2 inspections per year by qualified personnel and eventual emptying operations must be programmed according to the loads fed to the tank. Once the settled sludge has been removed, the internal surfaces of the tank must be cleaned in order to eliminate any material obstructing the effluent inlet and outlet pipes and the outlet of the sedimentation chamber.

During periodic inspections, also make sure that the sludge recirculation pipe is **working properly** and, if necessary, clean it internally using a jet of pressurised water.

TANK 2: periodically check the interior of the tank. If the trickle filter is working properly, the filter media will be covered by a thin layer of light brown biological sludge. When the filter media is **completely covered** with sludge and no empty spaces inside them are visible, or when the sludge takes on a darker colour it is necessary to pump out the tank. Like the Imhoff tank, the trickle filter normally requires cleaning and pumping out every 6-8 months.

Activation of the adhered biomass trickle filter, by formation of the bacterial film on the filter media, requires an initial period of 2-3 weeks. The activation processes can be optimised and speeded up by using the Rototec BIO-ACTIVATOR specific for aerobic treatment plants.

TANK 3: an excessive accumulation of sedimentable material in the sludge compartment can cause uncontrolled anaerobic digestion phenomena, leading to an **over-production of biogas** and malodorous emissions. Furthermore, the reduction in the volume available in the digestion compartment and the excessive production of gas bubbles will cause the settled material to rise, thus causing deterioration in the quality of the treated effluent. Once the settled sludge has been removed, the internal surfaces of the tank must be cleaned in order to eliminate any material obstructing the effluent inlet and outlet pipes and the outlet of the sedimentation chamber.

TECHNICAL SECTION - DEPURO PLUS⁺

MANAGEMENT

WHAT TO DO	WHEN	HOW
Inspect the primary sedimentation tank	From 1 to 2 times a year	Unscrew the inspection covers and check the level of sediments
Extract the bottom sludge, clean the interior and the inlet and outlet pipes	Every 6 / 12 months	Contact a licensed waste disposal company
Inspect the aerated adhered biomass tank	Every 6 / 12 months	Unscrew the inspection covers and check the level of sediments
Remove the settled sludge, clean the internal walls, the inlet and outlet pipes and backwash the filter media	Every 6 / 12 months	Contact a licensed waste disposal company
Clean the aerated adhered biomass tank pipe diffuser	Every 6 / 12 months	Contact a licensed waste disposal company (water jet pump-out)
Check that the blower in the aerated adhered biomass tank is working properly	Every month	Unscrew the cover on the inlet inspection hole and check that air is being blown into the aerated adhered biomass tank
Check that the recirculation blower is working properly	Every month	Unscrew the cover on the first Imhoff tank inlet inspection hole and check sludge recirculation

N.B. the frequency of operations will depend on the incoming organic load.

PROHIBITIONS

- **do not use toxic and/or poisonous substances** (bleach, solvents, insecticides, disinfectant substances, aggressive detergents), always use biodegradable products;
- **NEVER** flush paper tissues, kitchen towel, paper napkins or other materials except toilet paper down the toilet;
- **NEVER** allow rainwater to enter the system.

WARNINGS

- make sure that drains have a siphon;
- check that the pipes have sufficient gradient (approximately 1% - 2%);
- connect the biogas vent pipe in both tanks (**see underground installation**);
- after emptying, fill the tank again with **clean water**;
- in the event of a maintenance operation of any kind, always comply with the **safety regulations** regarding operations within enclosed wastewater treatment areas, and with the general technical procedures applicable.

TECHNICAL SECTION - DEPURO ACCESSORIES (INCLUDED IN THE SUPPLY)

BLOWER/COMPRESSOR

Rototec fits its aerated biomass tanks with diaphragm type air compressors which make use of the **electromagnetic vibration** of an actuator rod supported by rubber diaphragms. This system reduces **energy consumption to a minimum** by supplying constant air flows without any variations in working pressure. The blower does not have any moving parts in contact, and as such does **not require any lubrication**. Special attention is paid to the sound insulation and to the design of the vibrating section of the compressor in order to make it **as silent as possible**.



COMPRESSOR BLOWER

Model	Voltage V	Frequency Hz	Power W	Capacity (l/min)	Noise level (dBa)	Weight (kg)	Max length (mm)	Max width (mm)	Max height (mm)
HP 40	220	50	38	40	< 37	5.7	250	185	190
HP 60	220	50	56	60	<39	7	250	185	196
HP 80	220	50	78	80	< 41	7	250	185	196
HP 150	220	50	145	160	< 50	9	300	230	230
HP 200	220	50	186	200	< 50	12	300	230	250

Description: diaphragm type air compressors used in air-lift sludge return systems and for developing an aeration system necessary for the digestive processes of the aerobic bacteria, making use of the electromagnetic vibration of an actuator rod supported by synthetic rubber diaphragms.

INSTALLATION

- install in a special above ground technical room (with an environment free from corrosive gas), protected from the weather but with adequate ventilation to avoid overheating of the blower;
- **maximum distance of 10 m** from the aerated biomass tank;
- the blower must rest on a stable, flat surface, not exposed to vibration, at a level higher than that of the plant itself so as to avoid any return of the sludge if the air supply is interrupted;
- if necessary, provide ducting for the air pipe, running from the technical room to the edge of the tank (minimum diameter 80mm), and for the electric cable (minimum diameter 63mm);
- connect one end of the air feed pipe supplied to the outlet of the blower using the appropriate clips;
- connect the other end of the pipe to the coupling on the tank;
- when installation has been completed, connect the blower to the **power socket (220V, 50Hz)**.

MANAGEMENT

WHAT TO DO	WHEN	HOW
Check that the blower is working properly	Every month	Unscrew the cover on the inlet inspection hole and check that air is being blown into the tank
Clean the suction filter	Every 3 months	Remove the filter, eliminate excess dust and if necessary wash with mild detergent

PROHIBITIONS

- never connect the compressor to energy sources other than those indicated. In the case of doubt regarding making the connections, **DO NOT** connect up the equipment.

WARNINGS

- the operating temperature must be between -20°C and $+40^{\circ}\text{C}$ with relatively low humidity;
- always carry out all cleaning and/or replacement operations with the electric power supply disconnected;
- before carrying out any cleaning and/or replacement operation, make sure that the body of the compressor has cooled down, to avoid any risk of burns;
- when carrying out repairs, it is good practice only to use original materials in order to guarantee the safety of the equipment;
- maintenance operations that require the presence of electricity, such as detecting faults inside the blower, must only be carried out by qualified technicians;

TECHNICAL SECTION - DEPURO ACCESSORIES (INCLUDED IN THE SUPPLY)

PIPE DIFFUSERS

The pipe diffusers allow the air various passages, avoiding loss of load and guaranteeing an even distribution of oxygen at balanced concentrations throughout the tank, to optimise treatment in the oxidation system.

The micro-pores present all over the surface act like a valve. When they dilate the air comes out, otherwise, when the flow stops, they close and prevent the water from returning.



PIPE DIFFUSERS

Item	Ø mm	Length mm	Ø Bubbles mm	Capacity m³/h	Working temperature limit	Weight kg	Diaphragm material	Clip material
IFADNT600	60	300	1-3	5.1-15.3	From 0° to 120°C	0.9	Silicone	304 stainless steel

Application: micro-pore pipe diffusers used in oxidation plants, created to give even air distribution that optimises the system's treatment performance. The micro-pores act like a valve. When they dilate the air comes out, otherwise, when the flow stops, they close and prevent the water from returning.

INSTALLATION

- already fitted inside the tank and connected to the set-up provided;
- stays on the bottom of the tank thanks to its special micro-pore rubber structure.

MANAGEMENT

WHAT TO DO	WHEN	HOW
Clean the diffuser plate	During pump-out of the plant (every 6/12 months)	Contact a licensed waste disposal company (water jet pump-out)

WARNINGS

- during cleaning operations, lift the plate using the transparent pipe provided, paying attention to the set-up in the tank.

ELECTRIC PANEL CONTROLLING BLOWERS

The electric panel allows the system's two blower/compressors to be managed independently. Each blower has an ON/OFF switch, a thermal cut-out and a **digital timer** to adjust when it is turned on and off. The **thermal cut-outs** are connected to a LED and a **buzzer**, to indicate any malfunctions in one or both the blowers.



ADJUSTING THE TIMER

For proper operation of the plant it is necessary to set the times so as to adjust operation of the two blowers/compressors as indicated below:

- oxygenation: 1/2 an hour on, 1/2 an hour off during the whole 24 hours of one day;
- sludge recirculation: four times a day for 2 minutes at the following times: 11:00-11:02, 15:00-15:02, 22:00-22:02, 03:00-03:02.

WARNINGS

- Do not use the product in environments where there is dust, acids, corrosive and/or flammable gasses, etc...
- The panel must be moved with care, as falls or impact might cause damage that is not visible externally.
- Connection of the electric panel must be carried out by a qualified electrician, in compliance with current electrical regulations.
- The panel must be connected to an efficient earthing system, according to local electrical regulations in force.
- Before carrying out any type of control or maintenance operation, disconnect the power supply.
- If the alarm is triggered, disconnect the two blowers/compressors from the power supply and have a specialist technician check them to identify the problem.

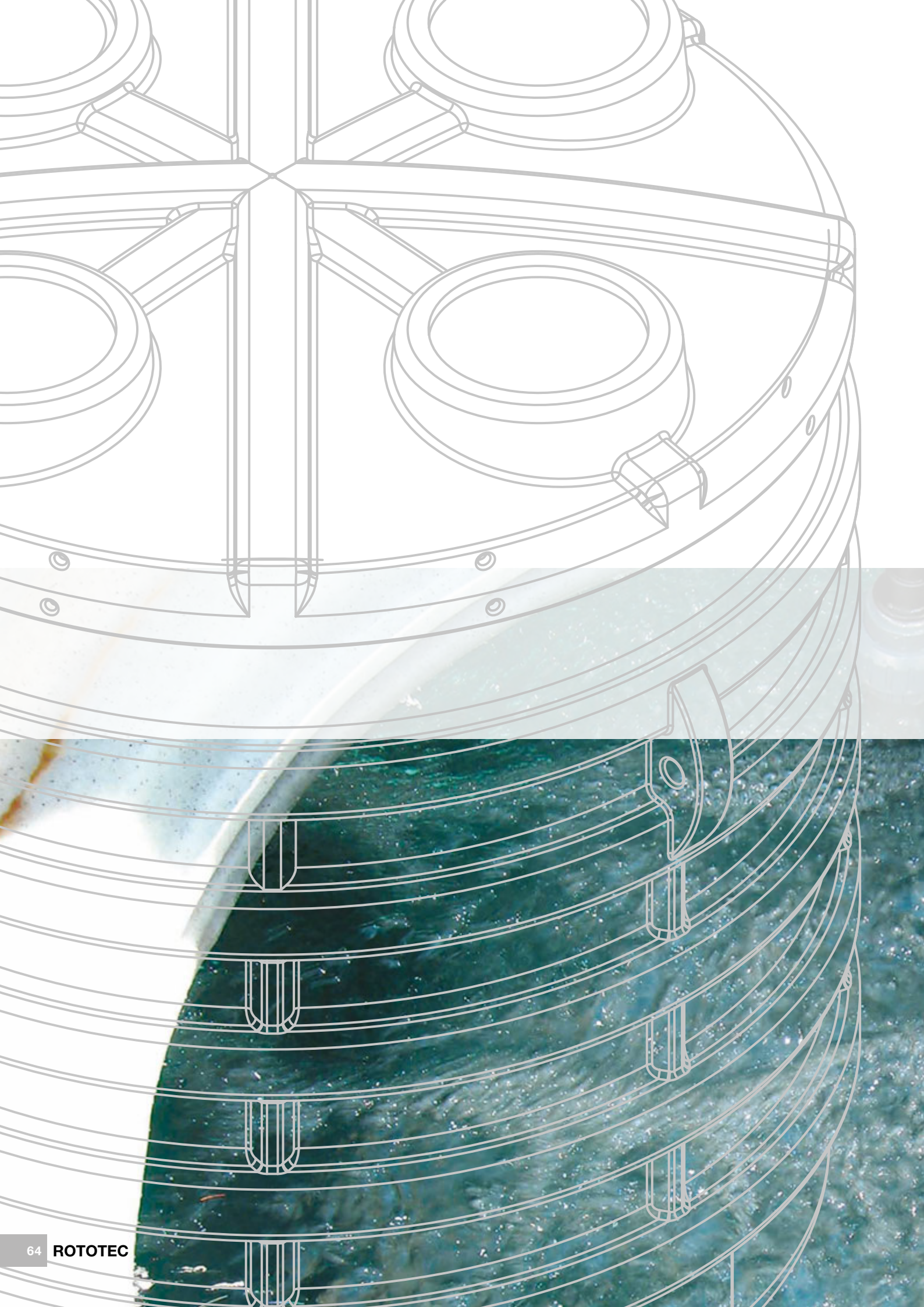

ACTIVATED SLUDGE PLANTS

A photograph of a wastewater treatment tank. The tank has a curved metal wall on the right side, which is light blue and shows some rust and debris. The water inside is dark blue and highly aerated, with many small bubbles. The top of the image is a white background with a semi-transparent grey band containing the title text.

ACTIVATED SLUDGE PLANT

LOW-LOAD



- 1 OXYGENATION AREA**
area in which the effluent is mixed and oxygenated, thanks to micro-bubble air diffuser plates, powered by an external blower/compressor. This develops aerobic bacteria that transform the biodegradable compounds into CO₂, organic nitrogen into ammonia and ammonia into nitrates.
- 2 SEDIMENTATION AREA**
stilling area in which the residual sludge sediments and returns once again to the oxygenation section.
- 3 OUTLET PIPE**
Fitted with a housing into which a slow release chlorine tablet could be inserted. In this way the effluent is disinfected before being discharged (where provided).
- 4 BLOWER**
(included).
- 5 DIFFUSER PLATE**
(included).

INSTALLATION DIAGRAM

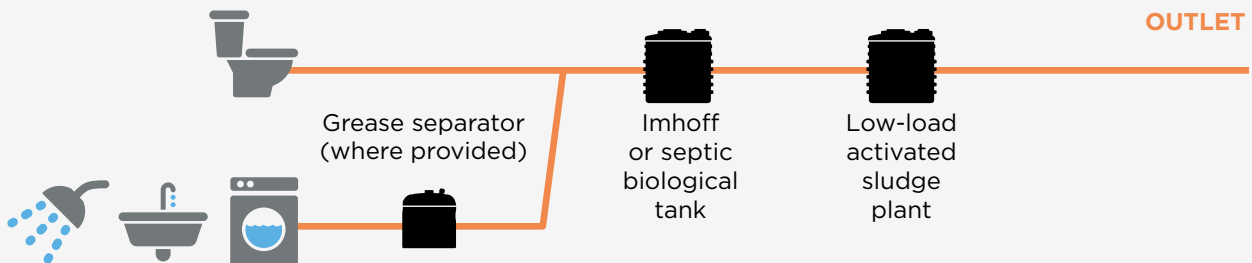

SPECIFICATIONS

TECHNICAL CHARACTERISTICS

Activated sludge plants are secondary treatment systems that make use of the action of the bacterial colonies that, remaining in suspension in the effluent, consume the biodegradable organic material, using it as a nutrient to obtain the necessary energy and the material required for the synthesis of new cells. In this manner, increasingly stable compounds are formed leading to the total degradation of the organic load. Very high concentrations of aerobic type bacteria are developed inside activated sludge plants, sufficient, that is, to absorb the dissolved oxygen in the water in order to consume the biodegradable material. To guarantee the concentration of oxygen necessary for the development of the biological reaction, an aeration system is adopted consisting of submerged diffusers to keep the high concentrations of solids present in the tank in suspension.

USE

Secondary treatment of domestic sewage.

DAILY HYDRAULIC LOAD: 200 l/PE

Please note: it is possible to size the treatment plant according to different daily hydraulic loads.

SEWAGE TREATMENT EFFICIENCY

The wastewater treatment system made up of a grease separator, an Imhoff biological tank and an activated sludge plant (installed as shown in the diagram at page 66) ensures that the concentrations of the final effluent are:

≤160 mg/l
COD

≤40 mg/l
BOD₅

≤80 mg/l
SS

These parameters are respected if the inlet wastewater have the following characteristics (typical concentrations of domestic sewage):

≤600 mg/l
COD

≤300 mg/l
BOD₅

≤400 mg/l
SS

ACTIVATED SLUDGE PLANT

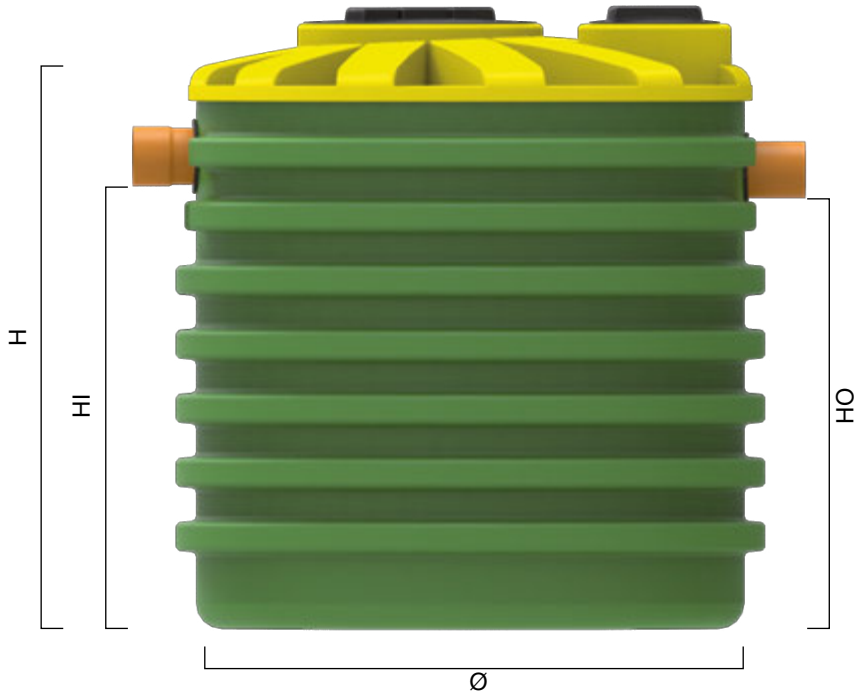

MODEL

CORRUGATED



ELIPSE









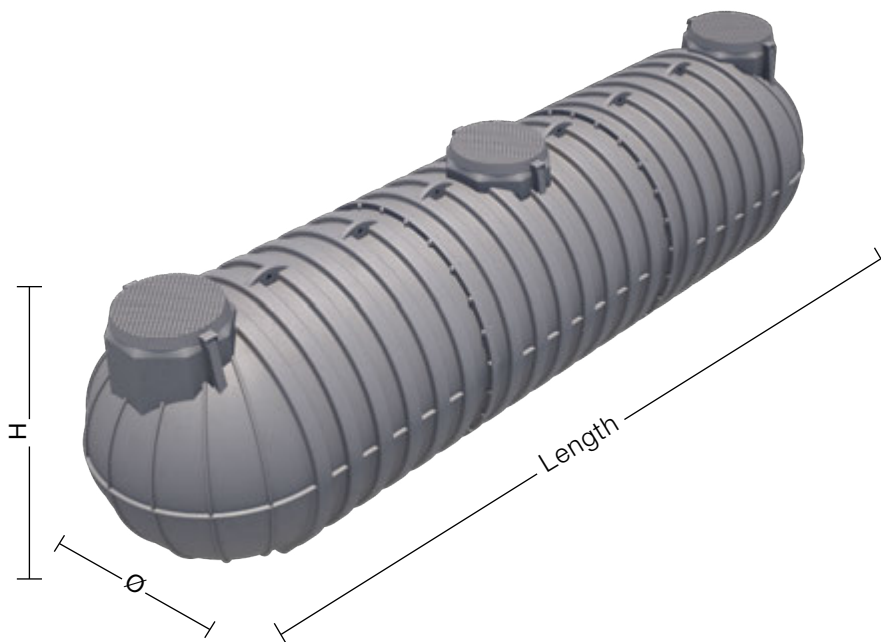









MODULAR



ACTIVATED SLUDGE PLANT MODULAR



ACTIVATED SLUDGE PLANT - LOW-LOAD

Item	Mod.	Length mm	Width mm	Ø mm	H mm	HI mm	HO mm	Ø I/O mm	Covers 1	Covers 2	Extens. 1 (optional)	Extens. 2 (optional)	Sedimentation Volume l	Aerated Volume l	Blower Volume l	Diffuser Plates No.	PE.
NIFA1000		-	-	1150	1220	880	860	110	CC400	CC200	PP45	PP30	243	607	HP40	1	6
NIFA1200		1900	708	-	1630	1250	1230	110	CC300	CC300	PP35	PP35	290	910	HP40	1	7
NIFA1500		-	-	1150	1720	1360	1340	110	CC400	CC200	PP45	PP30	362	906	HP40	1	9
NIFA1700		1900	708	-	2140	1760	1740	110	CC300	CC300	PP35	PP35	412	1363	HP40	1	9
NIFA2100		-	-	1350	1975	1540	1520	110	CC400	CC300	PP45	PP35	480	1470	HP60	2	12
NIFA2600		-	-	1710	1450	1000	980	125	CC400	CC300	PP45	PP35	629	1432	HP80	2	14
NIFA3200		-	-	1710	1725	1240	1220	125	CC400	CC300	PP45	PP35	760	1765	HP80	2	17
NIFA3800		-	-	1710	1955	1490	1470	125	CC400	CC300	PP45	PP35	965	2139	HP80	2	20
NIFA4600		-	-	1710	2225	1710	1690	160	CC400	CC300	PP45	PP35	1085	2713	HP80	2	25
NIFA5400		-	-	1950	2250	1660	1640	160	CC400	CC400	PP45	PP45	1210	3137	HP80	2	30
NIFA6400		-	-	1950	2530	1970	1950	160	CC400	CC400	PP45	PP45	1322	3778	HP80	2	35
NIFA7000		-	-	2250	2367	1850	1830	160	CC400	CC400	PP45	PP45	1460	5474	HP150	2	45
NIFA9000		-	-	2250	2625	2070	2050	160	CC400	CC400	PP45	PP45	2020	5803	HP150	2	52
ITIFA15000		5620	-	2100	2200	1870	1850	160	TAP800	-	PP77	-	402	14150	HP402SF	12	80
ITIFA22000		7880	-	2100	2200	1870	1850	160	TAP800	-	PP77	-	402	20700	HP402SF	18	120
ITIFA30000		10140	-	2100	2200	1870	1850	160	TAP800	-	PP77	-	402	27250	HP502SF	24	150
ITIFA36000		12400	-	2100	2200	1870	1850	160	TAP800	-	PP77	-	402	33800	HP502SF	30	180

PE. = population equivalent: Ø = diameter; H = height; HI = inlet pipe height; HO = outlet pipe height; ØI/O = inlet/outlet pipe diameter.

ACTIVATED SLUDGE PLANT

TOTAL OXIDATION



- 1 OXYGENATION AREA**
area in which the effluent is mixed and oxygenated, thanks to micro-bubble air diffuser plates, powered by an external blower/compressor. This develops aerobic bacteria that transform the biodegradable compounds into CO₂, organic nitrogen into ammonia and ammonia into nitrates.
- 2 OUTLET PIPE**
Fitted with a stilling pipe and a housing into which a slow release chlorine tablet could be inserted. In this way the effluent is disinfected before being discharged (where provided).
- 3 BLOWER**
(included)
- 4 DIFFUSER PLATE**
(included)

INSTALLATION DIAGRAM

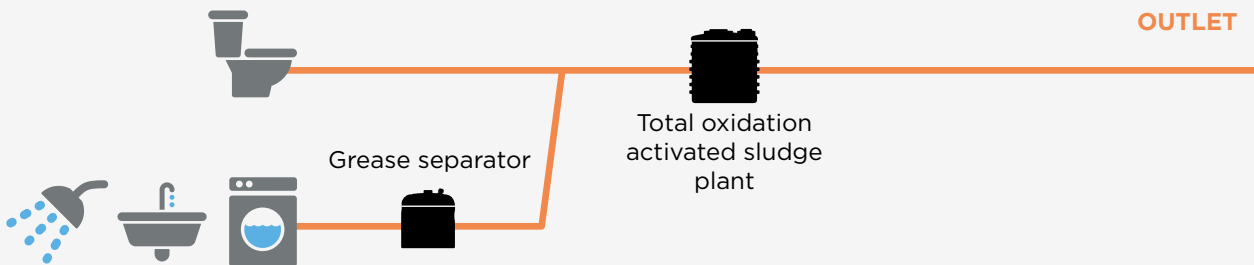

SPECIFICATIONS

TECHNICAL CHARACTERISTICS

Total oxidation activated sludge plants are primary (degreased) domestic sewage treatment systems that make use of the action of the bacterial colonies that, remaining in suspension in the effluent, consume the biodegradable organic material, using it as a nutrient to obtain the necessary energy and the material required for the synthesis of new cells. In this manner, increasingly stable compounds are formed leading to the total degradation of the organic load. Very high concentrations of aerobic type bacteria are developed inside activated sludge plants, sufficient, that is, to absorb the dissolved oxygen in the water in order to consume the biodegradable material. To guarantee the concentration of oxygen necessary for the development of the biological reaction, an aeration system is adopted consisting of submerged diffusers which, from the bottom of the tank, disperse a flow of fine air bubbles. This also guarantees sufficient mixing to keep the high concentrations of solids present in the tank in suspension.

USE

Primary and secondary treatment of degreased domestic sewage.

DAILY HYDRAULIC LOAD: 200 l/PE

Please note: it is possible to size the treatment plant according to different daily hydraulic loads.

SEWAGE TREATMENT EFFICIENCY

The wastewater treatment system made up of a grease separator and a total oxidation activated sludge plant (installed as shown in the diagram at page 70) ensures that the concentrations of the final effluent are:

≤160 mg/l
COD

≤40 mg/l
BOD₅

≤80 mg/l
SS

These parameters are respected if the inlet wastewater have the following characteristics (typical concentrations of domestic sewage):

≤600 mg/l
COD

≤300 mg/l
BOD₅

≤400 mg/l
SS

ACTIVATED SLUDGE PLANT

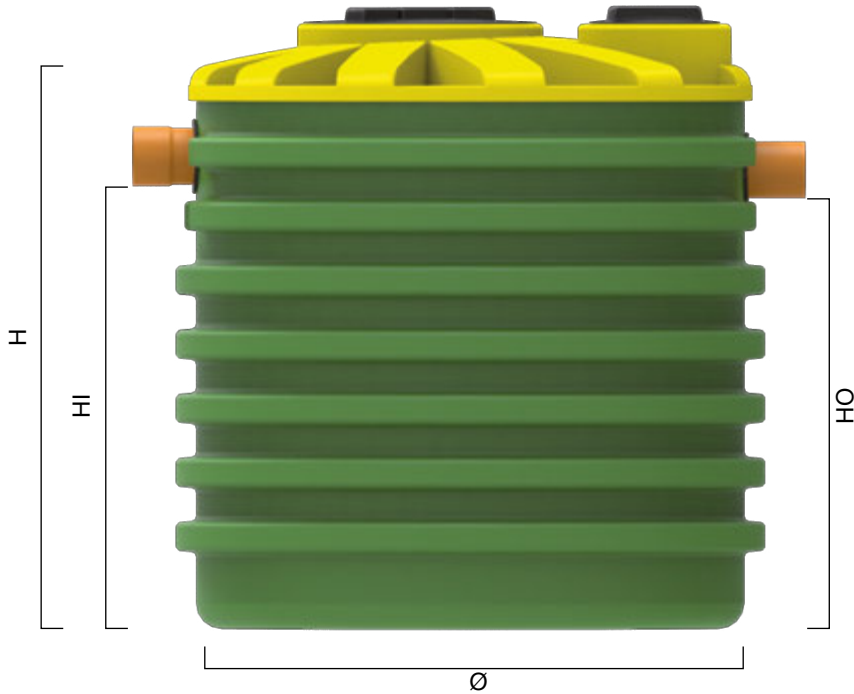

MODEL

CORRUGATED









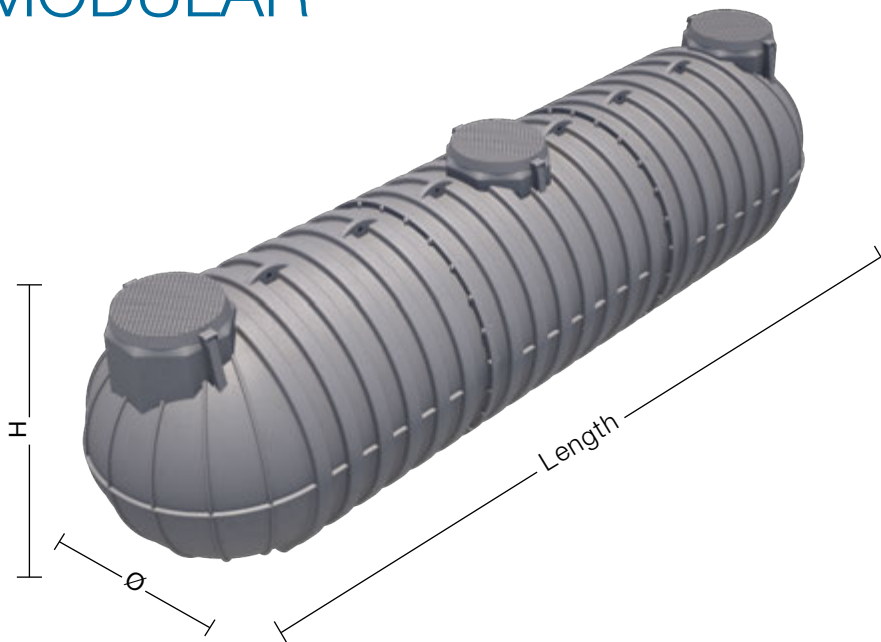







MODULAR



ACTIVATED SLUDGE PLANT MODULAR



ACTIVATED SLUDGE PLANT - TOTAL OXIDATION

Item	Mod.	Length mm	Width mm	Ø mm	H mm	HI mm	HO mm	Ø I/O mm	Covers 1	Covers 2	Extensions 1 (optional)	Extensions 2 (optional)	Aerated Vol. l	Blower Vol. l	Diffuser Plates No.	PE.
NIFAT1000		-	-	1150	1220	880	860	110	CC400	CC200	PP45	PP30	850	HP40	1	2
NIFAT1500		-	-	1150	1720	1360	1340	110	CC400	CC200	PP45	PP30	1268	HP40	1	4
NIFAT2100		-	-	1350	1975	1540	1520	110	CC400	CC300	PP45	PP35	1950	HP60	2	5
NIFAT2600		-	-	1710	1450	1000	980	125	CC400	CC300	PP45	PP35	2061	HP80	2	6
NIFAT3200		-	-	1710	1725	1240	1220	125	CC400	CC300	PP45	PP35	2525	HP80	2	8
NIFAT3800		-	-	1710	1955	1490	1470	125	CC400	CC300	PP45	PP35	3104	HP80	2	10
NIFAT4600		-	-	1710	2225	1710	1690	125	CC400	CC300	PP45	PP35	3594	HP80	2	12
NIFAT5400		-	-	1950	2250	1660	1640	125	CC400	CC400	PP45	PP45	4578	HP80	2	15
NIFAT6400		-	-	1950	2530	1970	1950	125	CC400	CC400	PP45	PP45	5293	HP80	2	20
NIFAT7000		-	-	2250	2367	1850	1830	125	CC400	CC400	PP45	PP45	6934	HP150	2	25
NIFAT9000		-	-	2250	2625	2070	2050	125	CC400	CC400	PP45	PP45	7823	HP150	2	30
ITIFAT15000		5620	-	2100	2200	1870	1850	160	TAP800	-	PP77	-	14150	HP402SF	12	50
ITIFAT22000		7880	-	2100	2200	1870	1850	160	TAP800	-	PP77	-	20700	HP402SF	18	75
ITIFAT30000		10140	-	2100	2200	1870	1850	160	TAP800	-	PP77	-	27250	HP502SF	24	100
ITIFAT36000		12400	-	2100	2200	1870	1850	160	TAP800	-	PP77	-	33800	HP502SF	30	130

PE. = population equivalent: Ø = diameter; H = height; HI = inlet pipe height; HO = outlet pipe height; ØI/O = inlet/outlet pipe diameter.

TECHNICAL SECTION - ACTIVATED SLUDGE PLANTS

TECHNICAL CHARACTERISTICS

Activated sludge plants are secondary treatment systems that make use of the action of the bacterial colonies that, remaining in suspension in the effluent, consume the biodegradable organic material, using it as a nutrient to obtain the necessary energy and the material required for the synthesis of new cells. In this manner, increasingly stable compounds are formed leading to the total degradation of the organic load. Very high concentrations of aerobic type bacteria are developed inside activated sludge plants, sufficient, that is, to absorb the dissolved oxygen in the water in order to consume the biodegradable material. To guarantee the concentration of oxygen necessary for the development of the biological reaction, an aeration system is adopted consisting of submerged diffusers which, from the bottom of the tank, disperse a flow of fine air bubbles. This also guarantees sufficient mixing to keep the high concentrations of solids present in the tank in suspension.

In the oxygen rich environment of the aeration tank, a number of different processes are set in motion:

- **Chemical**, i.e. the oxidation of malodorous compounds (hydrogen sulphide, sulphites...)
- **Physical**, i.e. the removal of effluent solids trapped by the dispersion of bacteria
- **Biological**, i.e. direct assimilation of the organic substances dissolved in the sewage.

The sizing of the activated sludge plants is performed on the basis of the **sludge load** (or organic load factor) expressed as the ratio between the organic load BOD_5 and the micro-organisms; the lower this ratio, the more intensely the organic load is consumed, at the same time reducing the production of excess sludge. Rototec activated sludge plants are sized to have sludge loads of less than 0.08 KgBOD / KgSSD with retention times of more than 24 hours at mean flows and volumetric loads of less than 0.25 KgBOD / m³d in the prolonged aeration (or total oxidation) configuration and sludge loads of less than 0.15 KgBOD/KgSSD and volumetric loads less than 0.5 KgBOD / m³d in the low-load configuration.

USE AND MAINTENANCE

The small user activated sludge plant is designed with the sedimentation compartment inside the oxidation tank in order to provide sewage settlement as well as sludge recirculation. This however leads to a build-up of solids in the oxidation chamber. It should be remembered that in order to ensure the correct operation of an activated sludge plant, a grease separator should be installed upstream of the reactor itself, and that the aeration should be kept on during the periods of use of the plant. The plant needs 10-15 days in order to reach normal operation. This time can be reduced however by adding biomass activators (Rototec bio activator) directly to the sewage.

MANAGEMENT

WHAT TO DO	WHEN	HOW
Inspect the activated sludge plant	Every 6 / 12 months	Unscrew the covers on the inspection holes and check the level of sediments
Check operation of the blower	Every month	Unfasten the inlet inspection hole cover and check that air is being blown in
Extract the bottom sludge, clean the interior, the inlet and outlet pipes and the diffuser plate	Every 6 / 12 months	Contact a licensed waste disposal company
Change the chlorine tablet	Every 2 months	Unfasten the outlet inspection hole cover and insert the tablet in the housing provided

N.B. the frequency of operations will depend on the incoming organic load.

PROHIBITIONS

- **do not use toxic and/or poisonous substances** (bleach, solvents, insecticides, disinfectant substances, aggressive detergents), always use biodegradable products;
- **NEVER** put the chlorine tablet into the plant, but insert it in the proper housing;
- **NEVER** drain rainwater into the system.

WARNINGS

- make sure that drains have a siphon;
- check that the pipes slope sufficiently (approximately 1% - 2%);
- connect the biogas vent pipe (**see installation method**);
- when discharging into the subsoil using a soil absorption system, provide a dosing siphon chamber downstream of the system, for better distribution of the effluent into the dispersion pipes;
- after pump-out, fill the tank again with **clean water**;
- in the event of a maintenance operation of any kind, always comply with the **safety regulations** regarding operations within closed waste water treatment areas, and with the general technical procedures applicable.

ACTIVATED SLUDGE PLANT ACCESSORIES (INCLUDED IN THE SUPPLY)

BLOWER/COMPRESSOR

Rototec fits its Activated Sludge plants with diaphragm type air compressors which make use of the **electromagnetic vibration** of an actuator rod supported by rubber diaphragms. This system reduces **energy consumption to a minimum**, by supplying constant air flows without any variations in working pressure. The blower does not have any moving parts in contact, and as such does **not require any lubrication**. Special attention is paid to the acoustic insulation and to the design of the vibrating section of the compressor in order to make it as **silent as possible**.



COMPRESSOR BLOWER

Model	Voltage V	Frequency Hz	Power W	Capacity (l/min)	Noise level (dBa)	Weight (kg)	Max length (mm)	Max width (mm)	Max height (mm)
HP 40	220	50	38	40	< 37	5.7	250	185	190
HP 60	220	50	56	60	<39	7	250	185	196
HP 80	220	50	78	80	< 41	7	250	185	196
HP 150	220	50	145	160	< 50	9	300	230	230
HP 200	220	50	186	200	< 50	12	300	230	250

INSTALLATION

- install in a special above ground technical room (with an environment free from corrosive gas), protected from the weather but with adequate ventilation to avoid overheating of the blower;
- **maximum distance of 10 m** from the activated sludge plant;
- the blower must rest on a stable, flat surface, not exposed to vibration, at a level higher than that of the plant itself so as to avoid any return of the sludge if the air supply is interrupted;
- if necessary, provide ducting for the air pipe, running from the technical room to the edge of the tank (minimum diameter 80mm), and for the electric cable (minimum diameter 63mm);
- connect one end of the air feed pipe supplied to the outlet of the blower using the appropriate clips;
- connect the other end of the pipe to the coupling on the tank;
- when installation has been completed, connect the blower to the **power socket (220V, 50Hz)**.

BLOWER TIMING

- the blower must remain switched on **24h a day for the first 2-3 months** in order to activate the purification processes;
- after the activation period, blower operation can be timed as follows: **2 hours ON- 30 minutes OFF** (repeated for all 24 hour periods)

MANAGEMENT

WHAT TO DO	WHEN	HOW
Check that the blower is working properly	Every month	Unfasten the cover on the inlet inspection hole and check that air is being blown into the tank
Clean the suction filter	Every 3 months	Remove the filter, eliminate excess dust and if necessary wash with mild detergent

PROHIBITIONS

- never connect the compressor to energy sources other than those indicated. If you have any doubts about how to do so, **DO NOT** connect up the equipment.

WARNINGS

- the operating temperature must be between -20°C and $+40^{\circ}\text{C}$ with relatively low humidity;
- always carry out all cleaning and/or replacement operations with the electric power supply disconnected;
- before carrying out any cleaning and/or replacement operation, make sure that the body of the compressor has cooled down, to avoid any risk of burns;
- when carrying out repairs, it is good practice only to use original materials in order to guarantee the safety of the equipment;
- maintenance operations that require the presence of electricity, such as detecting faults inside the blower, must only be carried out by qualified technicians;

ACTIVATED SLUDGE PLANT ACCESSORIES (INCLUDED IN THE SUPPLY)



SIDE CHANNEL COMPRESSORS/BLOWERS

construction of the ring blowers fan is based on the lateral ducts principle. The blowers can operate as either exhaust or compression fans and are designed for continuous service. The device is assembled directly on the motor shaft: all rotating parts are dynamically balanced to ensure absolute absence of vibration. Full die-cast aluminium construction for maximum sturdiness and ease of handling.

USE AND MAINTENANCE

the blower does not have any moving parts in contact, and as such does not require lubrication, its operation is long-term and does not require any other maintenance. It should, however, be installed in a suitable cabinet by qualified personnel.

BLOWER TIMING

- the blower must remain switched on **24h a day for the first 2-3 months** in order to activate the purification processes;
- after the activation period, blower operation can be timed as follows: **2 hours ON-30 minutes OFF** (repeated for all 24 hour periods)

Item	Voltage V	Frequency Hz	Power W	Absorption (A)	Noise level (dBA)	Weight (kg)	Length (mm)	Width (mm)	Height (mm)
HP302SF	220	50	0.7	4.5	< 55	15	458	316	270
HP302SF	380	50	1.6	5.6	< 66	24	485	401	315
HP302SF	380	50	3	10	< 72	38	597	465	371

HP302SF

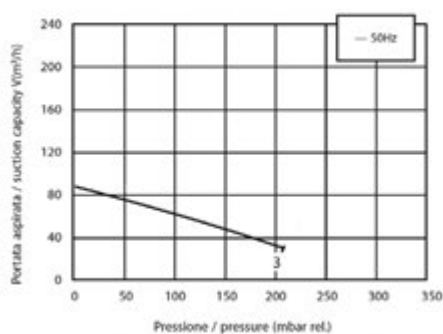

HP402SF

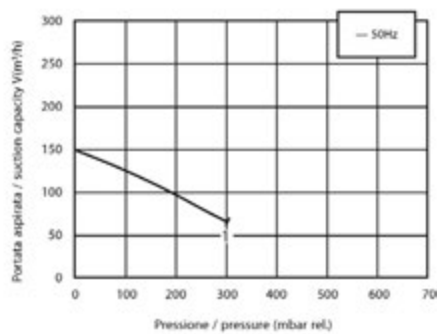

HP502SF

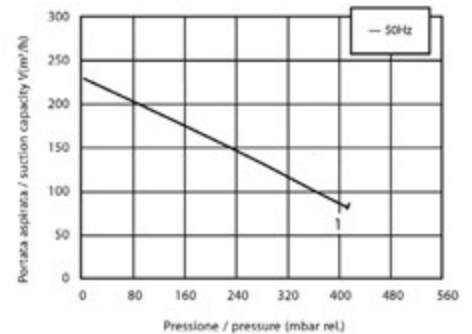

ACTIVATED SLUDGE PLANT ACCESSORIES (INCLUDED IN THE SUPPLY)

PLATE DIFFUSERS

In its activated sludge plants, Rototec uses diaphragm type diffusers in microbored rubber, constructed to provide a uniform distribution of air with bubbles of microscopic diameter designed to optimise the oxygenation of the effluent. The particular structure of the plates reduces the risk of blockages even during intermittent operation to a minimum and eliminates the possibility of its separation during the inspection phase, thus guaranteeing a high air flow with minimum head loss. The rubber lining of the rigid air distributor provides protection against accidental damage to the system, which will maintain its original characteristics over time. The innovative composition of the plate also ensures absolute impermeability of the connection between the diaphragm, the support plate and the support coupling.



Item	Diameter mm	Weight kg	Maximum air flow rate m ³ /h	Diameter of bubbles mm	Oxygenation capacity gO ₂ / Nm ³ per metre head
IFADN	211	2.1	5	1-3	18-20

INSTALLATION

- already fitted inside the tank and connected to the set-up provided;
- stays on the bottom of the tank thanks to its special micro-pore rubber structure.

MANAGEMENT

WHAT TO DO	WHEN	HOW
Clean the diffuser plate	During pump-out of the plant (every 6/12 months)	Contact a licensed waste disposal company (water jet pump-out)

WARNINGS

- during cleaning operations, lift the plate using the transparent pipe provided, paying attention to the set-up in the tank.

MEMBRANE AIR DIFFUSERS

rubber surface with microholes that act like one valve, dilating themselves in order to let out the air but closing up once the flow is interrupted preventing to the water to enter



APPLICATIONS

- Wastewater treatment
- Intermittent operation capability
- Clean water treatment
- Sludge stabilization
- Aeration of fish pond, streams and lakes

USE AND MAINTENANCE

the particular structure of the plates reduces the risk of blockages even during intermittent operation to a minimum and eliminates the possibility of its separation during the inspection phase, thus guaranteeing a high air flow with minimum head loss. The rubber lining of the rigid air distributor provides protection against accidental damage to the system, which will maintain its original characteristics over time. During the cleaning operations of the oxidation plant, clean the membrane air diffusers with water to avoid any clogging of the bored surface.

Item	Material	Diameter mm	Size and quantity of the bubbles	Connection	Air flow	Operation temperature	Diffusion area
IFADN250	High grade EPDM hardness 60° ±5	250	1-3 mm 8300 holes	R ¾" NPT	1,5-8,5 m ³ /h	0 – 100 °C	1,67 m

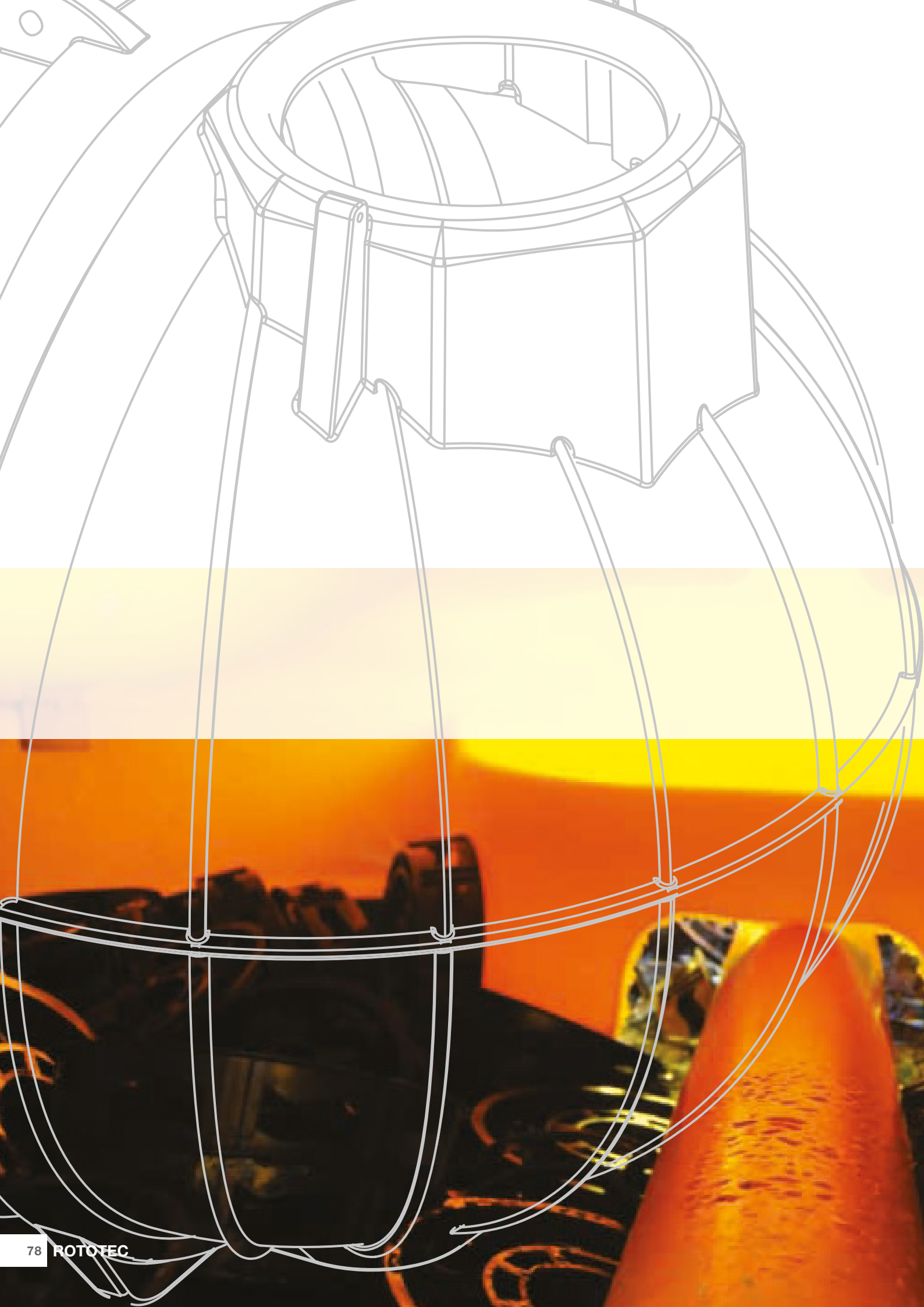

TRICKLE FILTERS



TRICKLE FILTERS

ANAEROBIC

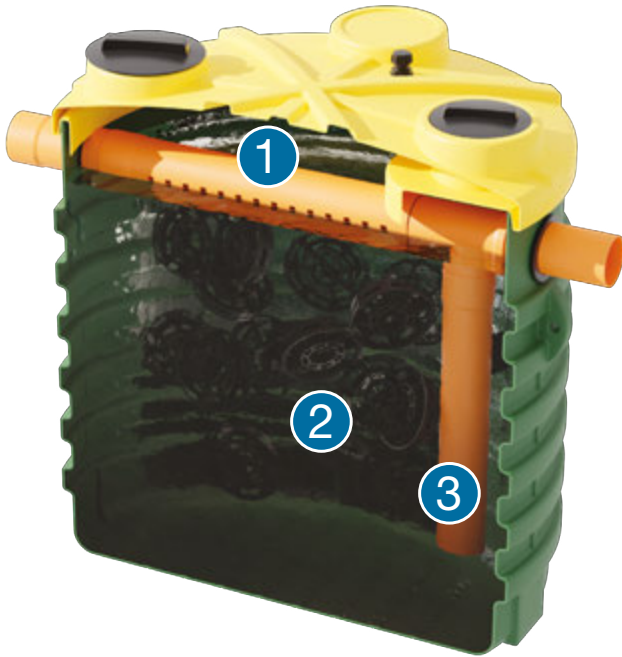

- 1 DISTRIBUTION PIPE**
bored pipe for even distribution of the effluent on the surface of the filter.
- 2 FILTER MEDIA**
plastic filler elements with a large surface area that act as a support on which the aerobic bacteria that treat the effluent can develop.
- 3 COLLECTION PIPE**
pipe to draw off the treated effluent from the bottom and send it to the outlet

INSTALLATION DIAGRAM

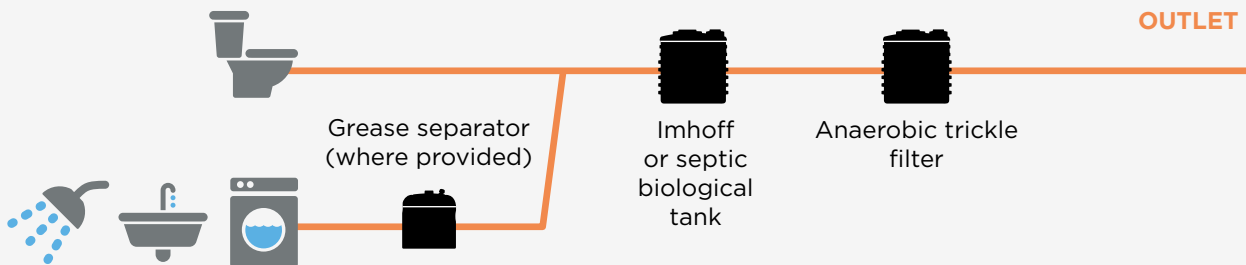

SPECIFICATIONS

TECHNICAL CHARACTERISTICS

A trickle filter is a biological reactor, inside which the micro-organisms that purify the effluent develop on the surface of special bulk fill material (filter media). The uniform distribution of the effluent through the filter guarantees maximum contact between the organic material to purify and the biological film covering the spheres making up the fill material. More specifically, the bacteria that grows and develops inside the anaerobic trickle filter consumes the organic load in the effluent in the absence of dissolved oxygen.

USE

Secondary treatment of domestic sewage.

DAILY HYDRAULIC LOAD: 200 l/PE

Please note: it is possible to size the treatment plant according to different daily hydraulic loads.

SEWAGE TREATMENT EFFICIENCY

The wastewater treatment system made up of a grease separator, an Imhoff biological tank and an anaerobic trickle filter (installed as shown in the diagram at page 80) ensures that the concentrations of the final effluent are:

≤160 mg/l
COD

≤40 mg/l
BOD₅

≤80 mg/l
SS

These parameters are respected if the inlet wastewater have the following characteristics (typical concentrations of domestic sewage):

≤600 mg/l
COD

≤300 mg/l
BOD₅

≤400 mg/l
SS

ANAEROBIC TRICKLE FILTERS

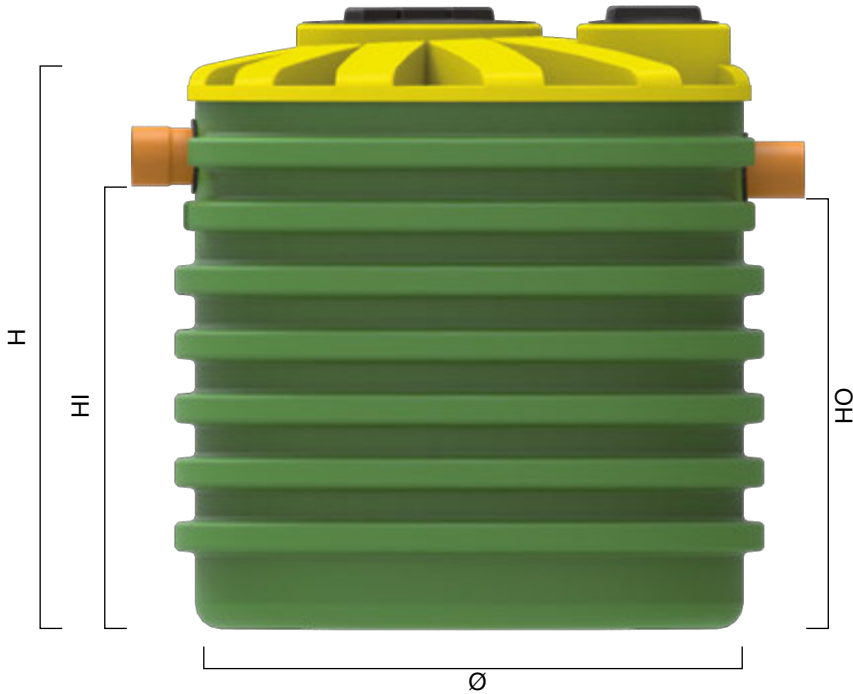

ANAEROBIC TRICKLE FILTERS MODULAR

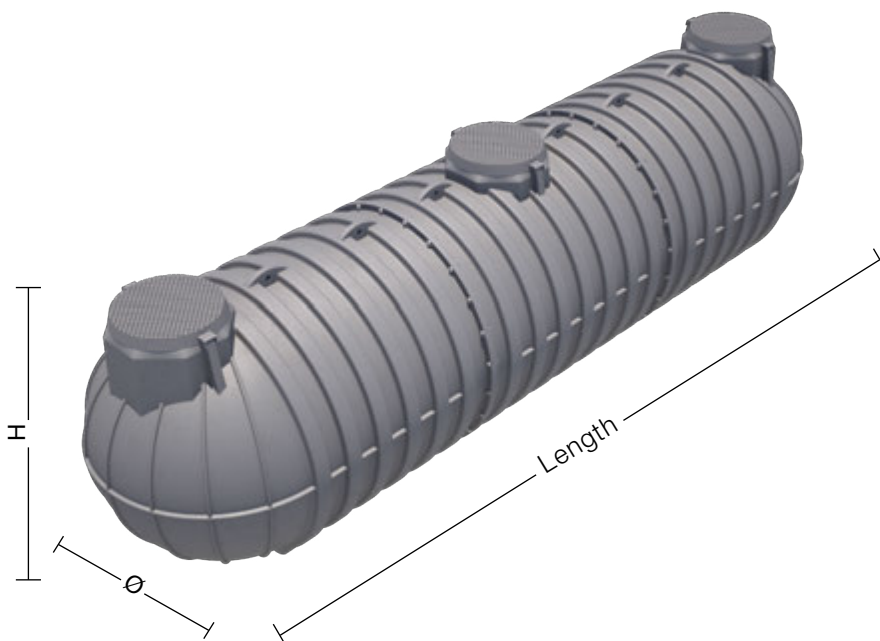

MODEL

CORRUGATED



UNDERGROUND
TANK





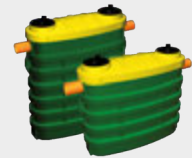

















ELIPSE



MODULAR



ANAEROBIC TRICKLE FILTER

Item	Mod.	Length mm	Width mm	Ø mm	H mm	HI mm	HO mm	Ø I/O mm	Covers 1	Covers 2	Extension 1 (optional)	Extension 2 (optional)	Filter surface m ²	Filter volume m ³	PE.
NAN700		-	-	1050	1030	760	740	110	CC400	CC200	PP45	PP30	0,63	0,58	3
NAN1000		-	-	1150	1220	880	860	110	CC400	CC200	PP45	PP30	1,04	0,85	6
NAN1200		1900	708	-	1630	1250	1230	110	CC300	CC300	PP35	PP35	1,35	1,20	7
NAN1250		-	-	1050	1250	970	950	110	CC400	CC200	PP45	PP30	0,63	1,15	7
NAN1500		-	-	1150	1720	1360	1340	110	CC400	CC200	PP45	PP30	1,04	1,26	9
NAN1700		1900	708	-	2140	1760	1740	110	CC300	CC300	PP35	PP35	1,35	1,77	10
NAN2100		-	-	1350	1975	1540	1520	110	CC400	CC300	PP45	PP35	1,39	1,80	11
NAN2600		-	-	1710	1450	1000	980	125	CC400	CC300	PP45	PP35	2,30	2,06	14
NAN3200		-	-	1710	1725	1240	1220	125	CC400	CC300	PP45	PP35	2,30	2,52	20
NAN3800		-	-	1710	1955	1490	1470	125	CC400	CC300	PP45	PP35	2,30	3,10	23
NAN4600		-	-	1710	2225	1710	1690	160	CC400	CC300	PP45	PP35	2,30	3,80	27
NAN5400		-	-	1950	2250	1660	1640	160	CC400	CC400	PP45	PP45	2,90	4,75	32
NAN6400		-	-	1950	2530	1970	1950	160	CC400	CC400	PP45	PP45	2,90	5,07	36
NAN7000		-	-	2250	2367	1850	1830	160	CC400	CC400	PP45	PP45	3,98	6,93	45
NAN9000		-	-	2250	2625	2070	2050	160	CC400	CC400	PP45	PP45	3,98	7,82	55
NAN10700		2780	2430	-	2660	2170	2130	160	TAP800	-	PP77	-	6,75	10,00	75
ITAN15000		5620	-	2100	2200	1830	1800	160	TAP800	-	PP77	-	10,20	14,15	100
ITAN22000		7880	-	2100	2200	1830	1800	160	TAP800	-	PP77	-	14,90	20,07	140
ITAN30000		10140	-	2100	2200	1810	1780	200	TAP800	-	PP77	-	19,16	27,25	200
ITAN36000		12400	-	2100	2200	1810	1780	200	TAP800	-	PP77	-	23,67	33,08	240

PE. = population equivalent: Ø = diameter; H = height; HI = inlet pipe height; HO = outlet pipe height; ØI/O = inlet/outlet pipe diameter.

AEROBIC TRICKLE FILTER TOP OUTLET WITH BLOWER (MBBR)



- 1 DISTRIBUTION PIPE**
bored pipe for even distribution of the effluent on the surface of the filter.
- 2 FILTER MEDIA**
plastic filler elements with a large surface area that act as a support on which the aerobic bacterial responsible for treating the effluent can develop.
- 3 COLLECTION PIPE**
pipe to draw off the treated effluent from the bottom and send it to the outlet.
- 4 COMPRESSOR BLOWER (MBBR)**
to pump the air inside the tank (included).
- 5 DIFFUSER PLATES**
for distribution of the air micro-bubbles (included).

INSTALLATION DIAGRAM

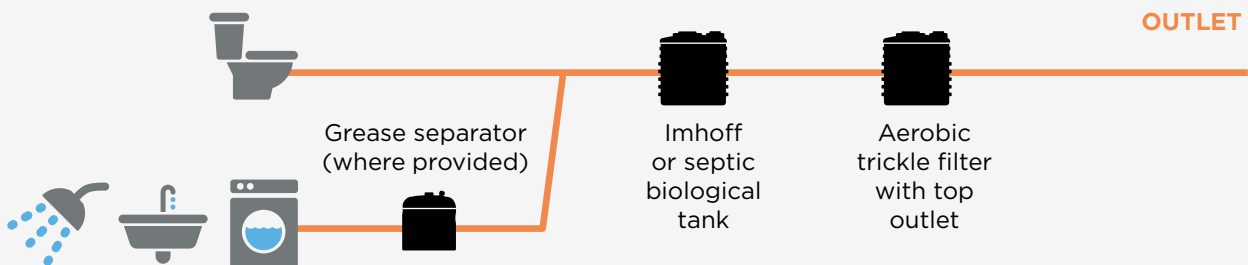

SPECIFICATIONS

TECHNICAL CHARACTERISTICS

A trickle filter is a biological reactor, inside which the micro-organisms that purify the effluent develop on the surface of special bulk fill material (filter media). The uniform distribution of the effluent through the filter guarantees maximum contact between the organic material to purify and the biological film covering the spheres making up the fill material. More specifically, the bacteria that grows and develops inside the aerobic trickle filter with top outlet (MBBR) consumes the organic load in the effluent in the presence of oxygen, continually entering the tank through the external compressor and distributed by the diffuser plates.

USE

Secondary treatment of domestic sewage.

DAILY HYDRAULIC LOAD: 200 l/PE

Please note: it is possible to size the treatment plant according to different daily hydraulic loads.

SEWAGE TREATMENT EFFICIENCY

The wastewater treatment system made up of a grease separator, an Imhoff biological tank and an aerobic trickle filter with top outlet MBBR (installed as shown in the diagram at page 84) ensures that the concentrations of the final effluent are:

≤160 mg/l
COD

≤40 mg/l
BOD₅

≤80 mg/l
SS

These parameters are respected if the inlet wastewater have the following characteristics (typical concentrations of domestic sewage):

≤600 mg/l
COD

≤300 mg/l
BOD₅

≤400 mg/l
SS

AEROBIC TRICKLE FILTER TOP OUTLET WITH BLOWER (MBBR)

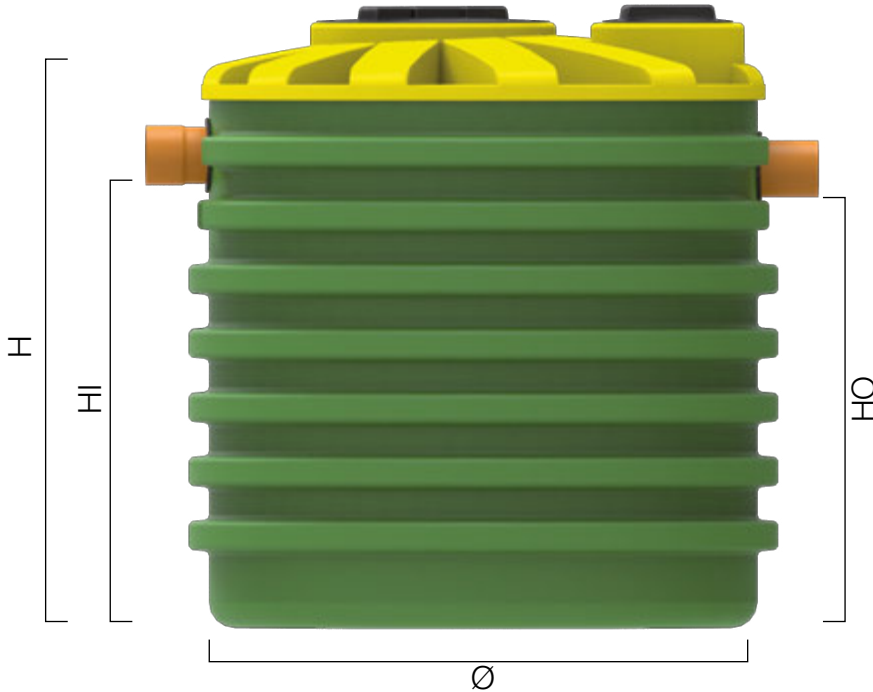

MODEL

CORRUGATED



UNDERGROUND
TANK



ELIPSE









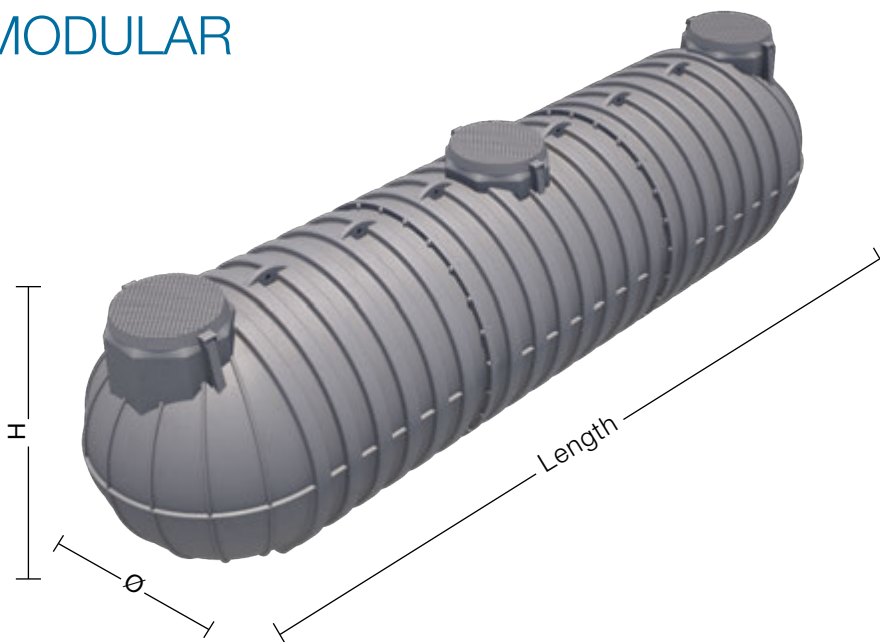











MODULAR



TRICKLE FILTER AEROBIC WITH TOP OUTLET MODULAR



AEROBIC TRICKLE FILTER WITH TOP OUTLET AND BLOWER (MBBR)

Item	Mod.	Length mm	Width mm	Ø mm	H mm	HI mm	HO mm	Ø I/O mm	Covers 1	Covers 2	Extension 1 (optional)	Extension 2 (optional)	Blowers	Filter surface m ²	Filter volume m ³	PE.
NARA1000		-	-	1150	1220	880	860	110	CC400	CC200	PP45	PP30	HP40	1,04	0,85	6
NARA1200		1900	708	-	1630	1250	1230	110	CC300	CC300	PP35	PP35	HP40	1,35	1,20	7
NARA1500		-	-	1150	1720	1360	1340	110	CC400	CC200	PP45	PP30	HP40	1,04	1,26	10
NARA1700		1900	708	-	2140	1760	1740	110	CC300	CC300	PP35	PP35	HP40	1,35	1,77	10
NARA2100		-	-	1350	1975	1540	1520	110	CC400	CC300	PP45	PP35	HP40	1,39	1,80	15
NARA2600		-	-	1710	1450	1000	980	125	CC400	CC300	PP45	PP35	HP60	2,30	2,06	16
NARA3200		-	-	1710	1725	1240	1220	125	CC400	CC300	PP45	PP35	HP60	2,30	2,52	20
NARA3800		-	-	1710	1955	1490	1470	125	CC400	CC300	PP45	PP35	HP60	2,30	3,10	23
NARA4600		-	-	1710	2225	1710	1690	125	CC400	CC300	PP45	PP35	HP60	2,30	3,80	28
NARA5400		-	-	1950	2250	1660	1640	125	CC400	CC400	PP45	PP45	HP60	2,90	4,75	32
NARA6400		-	-	1950	2530	1970	1950	125	CC400	CC400	PP45	PP45	HP60	2,90	5,07	38
NARA5700		2420	1920	-	2100	1690	1670	125	TAP800	-	PP77	-	HP80	3,78	5,60	42
NARA7000		-	-	2250	2367	1850	1830	125	CC400	CC400	PP45	PP45	HP80	3,98	6,93	50
NARA9000		-	-	2250	2625	2070	2050	125	CC400	CC400	PP45	PP45	HP80	3,98	7,82	56
NARA10700		2780	2430	-	2660	2170	2130	160	TAP800	-	PP77	-	HP80	6,75	10,00	80
ITARA15000		5620	-	2100	2200	1830	1800	160	TAP800	-	PP77	-	HP402SF	10,20	14,15	110
ITARA22000		7880	-	2100	2200	1830	1800	160	TAP800	-	PP77	-	HP402SF	14,90	20,07	150
ITARA30000		10140	-	2100	2200	1810	1780	200	TAP800	-	PP77	-	HP502SF	19,16	27,25	210
ITARA36000		12400	-	2100	2200	1810	1780	200	TAP800	-	PP77	-	HP502SF	23,67	33,08	250

PE. = population equivalent: Ø = diameter; H = height; HI = inlet pipe height; HO = outlet pipe height; ØI/O = inlet/outlet pipe diameter.

AEROBIC TRICKLE FILTER WITH TOP OUTLET AND BLOWER (MBBR) ACCESSORIES (INCLUDED IN THE SUPPLY)

BLOWER/COMPRESSOR

Rototec fits its Activated Sludge plants with diaphragm type air compressors which make use of the **electromagnetic vibration** of an actuator rod supported by rubber diaphragms. This system reduces **energy consumption to a minimum**, by supplying constant air flows without any variations in working pressure. The blower does not have any moving parts in contact, and as such does **not require any lubrication**. Special attention is paid to the acoustic insulation and to the design of the vibrating section of the compressor in order to make it **as silent as possible**.



COMPRESSOR BLOWER

Model	Voltage V	Frequency Hz	Power W	Capacity (l/min)	Noise level (dBa)	Weight (kg)	Max length (mm)	Max width (mm)	Max height (mm)
HP 40	220	50	38	40	< 37	5.7	250	185	190
HP 60	220	50	56	60	<39	7	250	185	196
HP 80	220	50	78	80	< 41	7	250	185	196
HP 150	220	50	145	160	< 50	9	300	230	230
HP 200	220	50	186	200	< 50	12	300	230	250

INSTALLATION

- install in a special above ground technical room (with an environment free from corrosive gas), protected from the weather but with adequate ventilation to avoid overheating of the blower;
- **maximum distance of 10 m** from the activated sludge plant;
- the blower must rest on a stable, flat surface, not exposed to vibration, at a level higher than that of the plant itself so as to avoid any return of the sludge if the air supply is interrupted;
- if necessary, provide ducting for the air pipe, running from the technical room to the edge of the tank (minimum diameter 80mm), and for the electric cable (minimum diameter 63mm);
- connect one end of the air feed pipe supplied to the outlet of the blower using the appropriate clips;
- connect the other end of the pipe to the coupling on the tank;
- when installation has been completed, connect the blower to the **power socket (220V, 50Hz)**.

BLOWER TIMING

- the blower must remain switched on **24h a day for the first 2-3 months** in order to activate the purification processes;
- after the activation period, blower operation can be timed as follows: **2 hours ON- 30 minutes OFF** (repeated for all 24 hour periods)

MANAGEMENT

WHAT TO DO	WHEN	HOW
Check that the blower is working properly	Every month	Unfasten the cover on the inlet inspection hole and check that air is being blown into the tank
Clean the suction filter	Every 3 months	Remove the filter, eliminate excess dust and if necessary wash with mild detergent

PROHIBITIONS

- never connect the compressor to energy sources other than those indicated. If you have any doubts about how to do so, DO NOT connect up the equipment.

WARNINGS

- the operating temperature must be between -20°C and +40°C with relatively low humidity;
- always carry out all cleaning and/or replacement operations with the electric power supply disconnected;
- before carrying out any cleaning and/or replacement operation, make sure that the body of the compressor has cooled down, to avoid any risk of burns;
- when carrying out repairs, it is good practice only to use original materials in order to guarantee the safety of the equipment;
- maintenance operations that require the presence of electricity, such as detecting faults inside the blower, must only be carried out by qualified technicians;



SIDE CHANNEL COMPRESSORS/BLOWERS

construction of the ring blowers fan is based on the lateral ducts principle. The blowers can operate as either exhaust or compression fans and are designed for continuous service. The device is assembled directly on the motor shaft: all rotating parts are dynamically balanced to ensure absolute absence of vibration. Full die-cast aluminium construction for maximum sturdiness and ease of handling.

USE AND MAINTENANCE

the blower does not have any moving parts in contact, and as such does not require lubrication, its operation is long-term and does not require any other maintenance. It should, however, be installed in a suitable cabinet by qualified personnel.

BLOWER TIMING

- the blower must remain switched on **24h a day for the first 2-3 months** in order to activate the purification processes;
- after the activation period, blower operation can be timed as follows: **2 hours ON-30 minutes OFF** (repeated for all 24 hour periods)

Item	Voltage V	Frequency Hz	Power W	Absorption (A)	Noise level (dBa)	Weight (kg)	Length (mm)	Width (mm)	Height (mm)
HP302SF	220	50	0.7	4.5	< 55	15	458	316	270
HP302SF	380	50	1.6	5.6	< 66	24	485	401	315
HP302SF	380	50	3	10	< 72	38	597	465	371

HP302SF

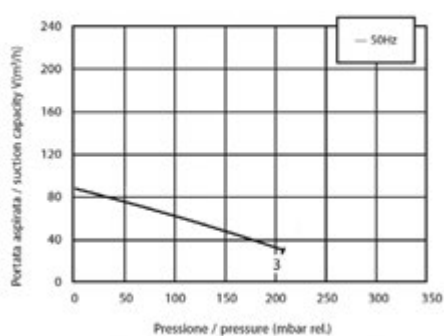

HP402SF

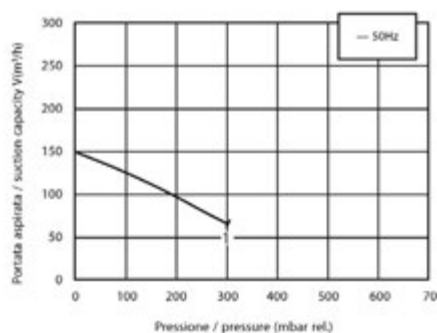

HP502SF

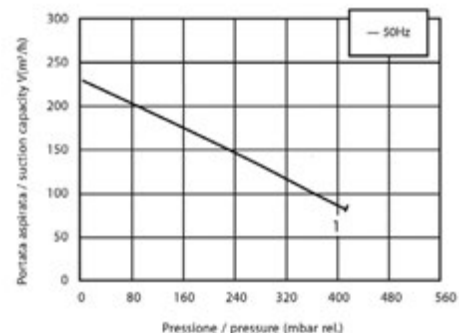

AEROBIC TRICKLE FILTER WITH TOP OUTLET AND BLOWER (MBBR) ACCESSORIES (INCLUDED IN THE SUPPLY)

PLATE DIFFUSERS

In its activated sludge plants, Rototec uses diaphragm type diffusers in microbored rubber, constructed to provide a uniform distribution of air with bubbles of microscopic diameter designed to optimise the oxygenation of the effluent. The particular structure of the plates reduces the risk of blockages even during intermittent operation to a minimum and eliminates the possibility of its separation during the inspection phase, thus guaranteeing a high air flow with minimum head loss. The rubber lining of the rigid air distributor provides protection against accidental damage to the system, which will maintain its original characteristics over time. The innovative composition of the plate also ensures absolute impermeability of the connection between the diaphragm, the support plate and the support coupling.



Item	Diameter mm	Weight kg	Maximum air flow rate m ³ /h	Diameter of bubbles mm	Oxygenation capacity gO ₂ / Nm ³ per metre head
IFADN	211	2.1	5	1-3	18-20

INSTALLATION

- already fitted inside the tank and connected to the set-up provided;
- stays on the bottom of the tank thanks to its special micro-pore rubber structure.

MANAGEMENT

WHAT TO DO	WHEN	HOW
Clean the diffuser plate	During pump-out of the plant (every 6/12 months)	Contact a licensed waste disposal company (water jet pump-out)

WARNINGS

- during cleaning operations, lift the plate using the transparent pipe provided, paying attention to the set-up in the tank.

MEMBRANE AIR DIFFUSERS

rubber surface with microholes that act like one valve, dilating themselves in order to let out the air but closing up once the flow is interrupted preventing to the water to enter



APPLICATIONS

- Wastewater treatment
- Intermittent operation capability
- Clean water treatment
- Sludge stabilization
- Aeration of fish pond, streams and lakes

USE AND MAINTENANCE

the particular structure of the plates reduces the risk of blockages even during intermittent operation to a minimum and eliminates the possibility of its separation during the inspection phase, thus guaranteeing a high air flow with minimum head loss. The rubber lining of the rigid air distributor provides protection against accidental damage to the system, which will maintain its original characteristics over time. During the cleaning operations of the oxidation plant, clean the membrane air diffusers with water to avoid any clogging of the bored surface.

Item	Material	Diameter mm	Size and quantity of the bubbles	Connection	Air flow	Operation temperature	Diffusion area
IFADN250	High grade EPDM hardness 60° ±5	250	1-3 mm 8300 holes	R ¾" NPT	1,5-8,5 m ³ /h	0 – 100 °C	1,67 m

TECHNICAL SECTION – TRICKLE FILTERS

TECHNICAL CHARACTERISTICS

A trickle filter is a biological reactor, inside which the micro-organisms that purify the effluent develop on the surface of **special bulk fill material (filter media)**. The uniform distribution of the effluent through the filter guarantees maximum contact between the organic material to purify and the biological film covering the spheres making up the fill material.

The spheres making up the filter media are manufactured in polypropylene and are designed to provide a large surface area available for bacterial micro-organisms to take root. In particular, the spheres used provide a **surface area per unit volume of filter media of 140 m²/m³**, much higher than the traditional stone fill material, with **voids accounting for over 90%**. This solution minimises the risk of clogging the bed and also guarantees an improved circulation of air through the bed of the aerobic filter. Trickle filters allow good purification performance **without any energy overheads**, with management costs limited to the occasional cleaning of the plant.

The sizing of percolating filters for an average domestic effluent refers to the organic load factor kgBOD/m³d with which the filter is fed. This parameter is the ratio between the organic load at the inlet kg BOD₅d and the volume of the filter bed. Rototec trickle filters are designed to operate with medium-low organic load factors kg BOD₅ / m³d. This guarantees a good margin of safety, with respect to fluctuations in inlet flow, and a limited production of excess sludge.

USE AND MAINTENANCE

The filter is designed to ensure **minimum clogging risk**. However, the development of the films on the filter media can over time excessively dirty the filter, with the resulting risk of solids being discharged with the treated effluent.

Cleaning operations are normally carried out as part of the Imhoff tank inspection and emptying operations. It should be remembered that in order for the trickle filter to function correctly, the effluent must first be subjected to sedimentation treatment in an Imhoff tank or similar installed upstream of the filter. The use of Rototec Bio-Activators is recommended for rendering the starting of the biological processes more rapid.

MANAGEMENT

WHAT TO DO	WHEN	HOW
Inspect the trickle filter	Every 12 months	Unscrew the covers on the inspection holes and check the level of sediments
Extract the bottom sludge, clean the interior and the inlet and outlet pipes and backwash the filter media	Every 12 / 15 months	Contact a licensed waste disposal company

N.B. the frequency of operations will depend on the incoming organic load.

PROHIBITIONS

- **do not use toxic and/or poisonous substances** (bleach, solvents, insecticides, disinfectant substances, aggressive detergents); always use biodegradable products;
- **NEVER** drain rainwater into the system.

WARNINGS

- make sure that drains have a siphon;
- check that the pipes slope sufficiently (approximately 1% - 2%);
- connect the biogas vent pipe (**see installation method**).
- **when discharging to a surface watercourse**, install a septic tank (Imhoff or other septic tank) downstream of the trickle filter as the final effluent sedimentation and clarification phase;
- when discharging into the subsoil using a soil absorption system, provide a **dosing siphon chamber** downstream of the system, for better distribution of the effluent into the dispersion pipes;
- after pump-out, fill the tank again with **clean water**;
- in the event of a maintenance operation of any kind, always comply with the **safety regulations** regarding operations within closed waste water treatment areas, and with the general technical procedures applicable.

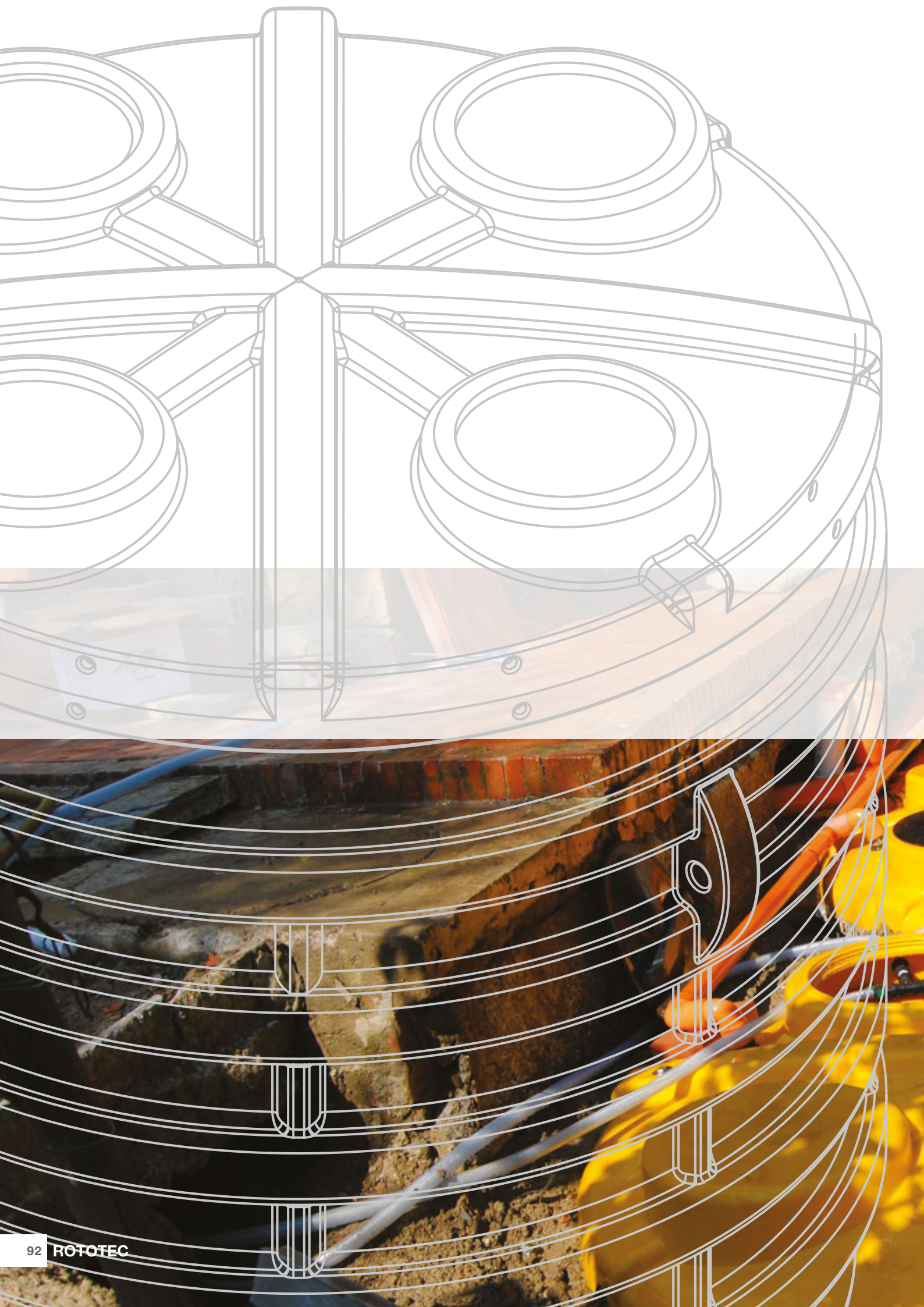

HIGH EFFICIENCY SECONDARY TREATMENTS



HIGH EFFICIENCY SECONDARY TREATMENTS (DEP RF) WITH SLUDGE RETURN

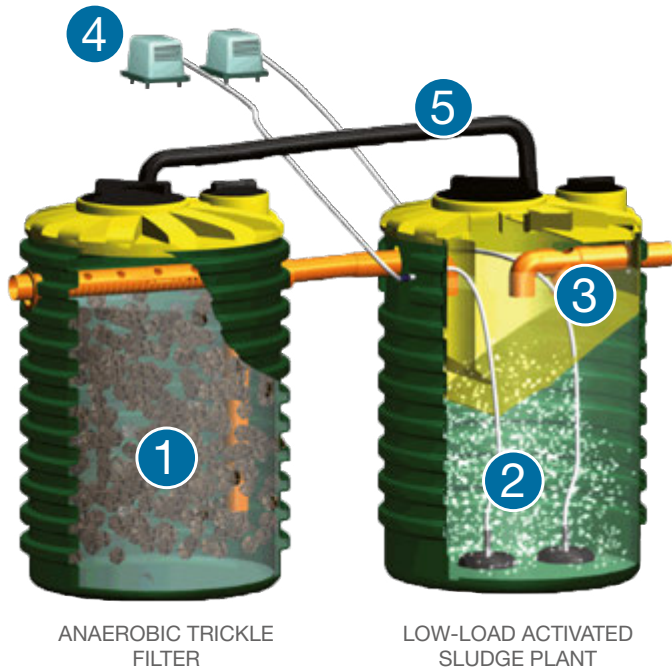

- 1 FILTER MEDIA**
plastic filler elements with a large surface area that act as a support on which the anaerobic bacteria responsible for treating the effluent can develop.
- 2 OXYGENATION AREA**
area in which the effluent is mixed and oxygenated, thanks to micro-bubble air diffuser plates, powered by an external blower/compressor. This develops aerobic bacteria that transform the biodegradable compounds into CO₂, organic nitrogen into ammonia and ammonia into nitrates.
- 3 FINAL SEDIMENTATION AND DISINFECTION AREA**
stilling area in which the residual sludge sediments and returns once again to the oxygenation section. The outlet pipe is fitted with a housing into which a slow release chlorine tablet could be inserted. In this way the effluent is disinfected before being discharged (where provided).
- 4 BLOWERS-COMPRESSORS**
for forced blowing of oxygen into the activated sludge plant and for air-lift recirculation system (included).
- 5 SLUDGE RECIRCULATION PIPE**

INSTALLATION DIAGRAM

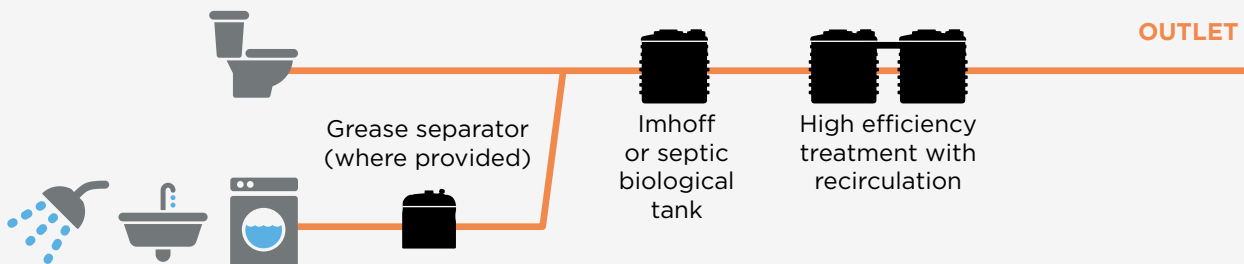

SPECIFICATIONS

TECHNICAL CHARACTERISTICS

Secondary treatments consisting of an anaerobic trickle filter and an activated sludge plant with sludge recirculation allow almost 100% removal of the organic load and suspended solids with a very high reduction in the nitrogen load and phosphorous load found in domestic sewage. In this way, the waste water discharged respects the limits indicated in table 4 of attachment 5 to Legislative Decree 152/2006 for discharge to land. The trickle filter is a biological reactor in which the micro-organisms, under anaerobic conditions, make use of the biodegradable substance contained in the effluent. These micro-organisms develop on the surface of special bulk fill material in polypropylene, specifically designed to maximise the contact surface area between the micro-organisms and the effluent. Activated sludge plants are systems in which the bacterial flora develops in colonies that remain in suspension in the effluent and consume the remaining biodegradable material. The process is fully aerobic and the oxygen necessary for the development of the bacteria is supplied by submersed diffusers that emit a flow of fine bubbles of air from the bottom of the tank. This also guarantees continuous effluent mixing. The sludge recirculation system is used to create optimum conditions to develop and maintain the bacteria responsible for removal of the various pollutants present in the effluent.

USE

High level secondary treatment of domestic sewage.

DAILY HYDRAULIC LOAD: 200 l/PE

Please note: it is possible to size the treatment plant according to different daily hydraulic loads.



SEWAGE TREATMENT EFFICIENCY

The wastewater treatment systems made up of a grease separator, an Imhoff biological tank and a high efficiency secondary treatment (installed as shown in the diagram at page 94) ensures that the concentrations of the final effluent are:

≤100 mg/l
COD

≤20 mg/l
BOD₅

≤25 mg/l
SS

These parameters are respected if the inlet wastewater have the following characteristics (typical concentrations of domestic sewage):

≤600 mg/l
COD

≤300 mg/l
BOD₅

≤400 mg/l
SS

HIGH EFFICIENCY SECONDARY TREATMENTS

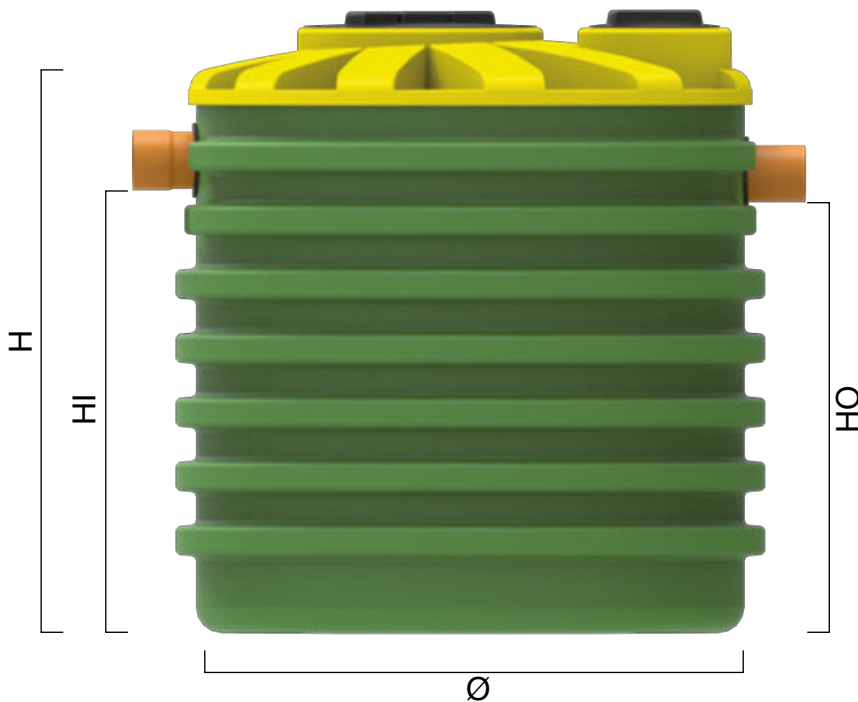

MODEL

CORRUGATED



HIGH EFFICIENCY SECONDARY TREATMENTS WITH SLUDGE RECIRCULATION (DEP RF)

Item	Mod.	Anaerobic trickle filter							Impianto a fanghi attivi									PE.		
		Item	Ø mm	H mm	Cov. 1	Cov. 2	Extens. 1 (optional)	Extens. 2 (optional)	Filter Vol. m³	Item	Ø mm	H mm	Cov. 1	Cov. 2	Extens. 1 (optional)	Extens. 2 (optional)	Aerated vol. l		Sed. vol. l	Blowers
DEP07RF		NAN 1000R	1150	1220	CC400	CC200	PP45	PP30	0,85	NIFA 1000R	1150	1220	CC400	CC200	PP45	PP30	607	243	HP40-HP40	7
DEP09RF		NAN 1000R	1150	1220	CC400	CC200	PP45	PP30	0,85	NIFA 1500R	1150	1720	CC400	CC200	PP45	PP30	906	362	HP40-HP40	9
DEP11RF		NAN 1500R	1150	1720	CC400	CC200	PP45	PP30	1,26	NIFA 1500R	1150	1720	CC400	CC200	PP45	PP30	906	362	HP40-HP40	11
DEP13RF		NAN 1500R	1150	1720	CC400	CC200	PP45	PP30	1,26	NIFA 2600R	1710	1450	CC400	CC300	PP45	PP35	1432	629	HP80-HP60	13
DEP15RF		NAN 2600R	1710	1450	CC400	CC300	PP45	PP35	2,06	NIFA 2600R	1710	1450	CC400	CC300	PP45	PP35	1432	629	HP80-HP60	15
DEP17RF		NAN 2600R	1710	1450	CC400	CC300	PP45	PP35	2,06	NIFA 3200R	1710	1725	CC400	CC300	PP45	PP35	1765	760	HP80-HP60	17
DEP20RF		NAN 3200R	1710	1725	CC400	CC300	PP45	PP35	2,52	NIFA 3200R	1710	1725	CC400	CC300	PP45	PP35	1765	760	HP80-HP60	20
DEP23RF		NAN 3200R	1710	1725	CC400	CC300	PP45	PP35	2,52	NIFA 3800R	1710	1955	CC400	CC300	PP45	PP35	2139	965	HP80-HP60	23
DEP26RF		NAN 3800R	1710	1955	CC400	CC300	PP45	PP35	3,10	NIFA 3800R	1710	1955	CC400	CC300	PP45	PP35	2139	965	HP80-HP60	26
DEP30RF		NAN 3800R	1710	1955	CC400	CC300	PP45	PP35	3,10	NIFA 4600R	1710	2225	CC400	CC300	PP45	PP35	2713	1085	HP80-HP80	30
DEP35RF		NAN 4600R	1710	2225	CC400	CC300	PP45	PP35	3,80	NIFA 4600R	1710	2225	CC400	CC300	PP45	PP35	2713	1085	HP80-HP80	35
DEP40RF		NAN 4600R	1710	2225	CC400	CC300	PP45	PP35	3,80	NIFA 7000R	2250	2367	CC400	CC400	PP45	PP45	5474	1460	HP150-HP150	40
DEP47RF		NAN 7000R	2250	2367	CC400	CC400	PP45	PP45	6,93	NIFA 7000R	2250	2367	CC400	CC400	PP45	PP45	5474	1460	HP150-HP150	47
DEP52RF		NAN 7000R	2250	2367	CC400	CC400	PP45	PP45	6,93	NIFA 9000R	2250	2625	CC400	CC400	PP45	PP45	5803	2020	HP150-HP150	52
DEP60RF		NAN 9000R	2250	2625	CC400	CC400	PP45	PP45	7,82	NIFA 9000R	2250	2625	CC400	CC400	PP45	PP45	5803	2020	HP150-HP150	60

PE. = population equivalent: Ø = diameter; H = height; HI = inlet pipe height; HO = outlet pipe height; ØI/O = inlet/outlet pipe diameter.

TECHNICAL SECTION HIGH EFFICIENCY SECONDARY TREATMENTS WITH SLUDGE RECIRCULATION

TECHNICAL CHARACTERISTICS

Secondary treatments consisting of an anaerobic trickle filter and an activated sludge plant with recirculation allow almost 100% removal of the organic load and suspended solids with a very high reduction in the nitrogen load and phosphorous load found in domestic sewage. The trickle filter is a biological reactor in which the micro-organisms, under anaerobic conditions, make use of the biodegradable substance contained in the effluent. These micro-organisms develop on the surface of special bulk fill material in polypropylene, specifically designed to maximise the contact surface area between the micro-organisms and the effluent.

Activated sludge plants are systems in which the bacterial flora develops in colonies that remain in suspension in the effluent and consume the remaining biodegradable material. The process is fully aerobic and the oxygen necessary for the development of the bacteria is supplied by submersed diffusers that emit a flow of fine bubbles of air from the bottom of the tank. This also guarantees continuous effluent mixing. Thanks to the recirculation system, a part of the sludge present in the tank is recirculated to the percolator by means of an air lift system. In this way, the removal of the organic load, the nitrogen and the phosphorous is the maximum possible, allowing the effluent to be re-used for irrigation (if the Local Regulations allow the re-use of treated water) or for discharge to highly protected areas.

The outlet from the activated sludge plant is equipped with a housing in which it is possible to insert a chlorine tablet. This allows the effluent leaving the treatment plant to be disinfected before being stored.

USE AND MAINTENANCE

Bacterial organisms develop inside the two tanks forming the treatment system and transform the pollutants into inert sludge which tends to accumulate at the bottom and on the filter media of the trickle filter. Over time, an excessive accumulation of sludge leads to the release of these bacterial organisms with the resulting deterioration in the quality of the final effluent. For this reason, the tanks need to be inspected and subjected to periodic maintenance. These operations are normally carried out as part of the Imhoff tank inspection and emptying operations.

During the tank inspection operations, make sure that there is a continuous supply of air being blown into the activated sludge plant and a recirculation of sludge to the anaerobic trickle filter. It should also be remembered that in order to ensure the correct operation of the plant, a grease separator and Imhoff tank or similar should be installed upstream of the plant itself. Furthermore, particular attention should be paid to the discharge of disinfectants, bleaches, strong acids or bases which could deactivate the biomass. The plant needs 10-15 days in order to reach normal operation. This time can be reduced however by adding biomass activators (Rototec Bioactivator) directly to the sewage.

PROHIBITIONS

- **do not use toxic and/or poisonous substances** (bleach, solvents, insecticides, disinfectant substances, aggressive detergents); always use biodegradable products;
- **NEVER** put the chlorine tablet into the activated sludge plant, but insert it in the proper housing;
- **NEVER** drain rainwater into the system.

WARNINGS

- make sure that drains have a siphon;
- check that the pipes slope sufficiently (approximately 1% - 2%);
- connect the biogas vent pipe in both tanks (**see installation method**);
- after pump-out, fill the tanks again with **clean water**;
- in the event of a maintenance operation of any kind, always comply with the **safety regulations** regarding operations within closed waste water treatment areas, and with the general technical procedures applicable.

WARNINGS (blower)

- the operating temperature must be between -20°C and $+40^{\circ}\text{C}$ with relatively low humidity;
- always carry out all cleaning and/or replacement operations **with the electric power supply disconnected**;
- before carrying out any cleaning and/or replacement operation, make sure that the body of the compressor has **cooled down**, to avoid any risk of burns;
- when carrying out repairs, it is good practice only to use **original materials** in order to guarantee the safety of the equipment;
- maintenance operations that require the presence of electricity, such as detecting faults inside the blower, must only be carried out by **qualified technicians**.
- never connect the compressor to energy sources other than those indicated. If you have any doubts about making the connections, **DO NOT** connect the equipment.

MANAGEMENT

WHAT TO DO	WHEN	HOW
Inspect the activated sludge plant	Every 6 / 12 months	Unscrew the covers on the inspection holes and check the level of sediments
Inspect the trickle filter	Every 6 / 12 months	Unscrew the covers on the inspection holes and check the level of sediments
Check that the blower in the activated sludge plant is working	Every month	Unfasten the cover on the inlet inspection hole and check that air is being blown into the activated sludge plant
Check that the blower in the Air-lift sludge recirculation is working	Every month	Unscrew the cover on the trickle filter inlet manhole and check the sludge recirculation
Clean the blowers suction filter	Every 3 months	Remove the filter, eliminate excess dust and if necessary wash with mild detergent
Extract the bottom sludge, clean the interior and the inlet and outlet pipes	Every 6 / 12 months	Contact a licensed waste disposal company
Clean the plate diffuser in the activated sludge plant	Every 6 / 12 months	Contact a licensed waste disposal company (water jet pump-out)
Backwash the filter media in the trickle filter	Every 6 / 12 months	Contact a licensed waste disposal company (water jet pump-out)

N.B. the frequency of operations will depend on the incoming organic load.





DEPURBLOK

ONE-PIECE TREATMENT PLANTS



IFABLOK

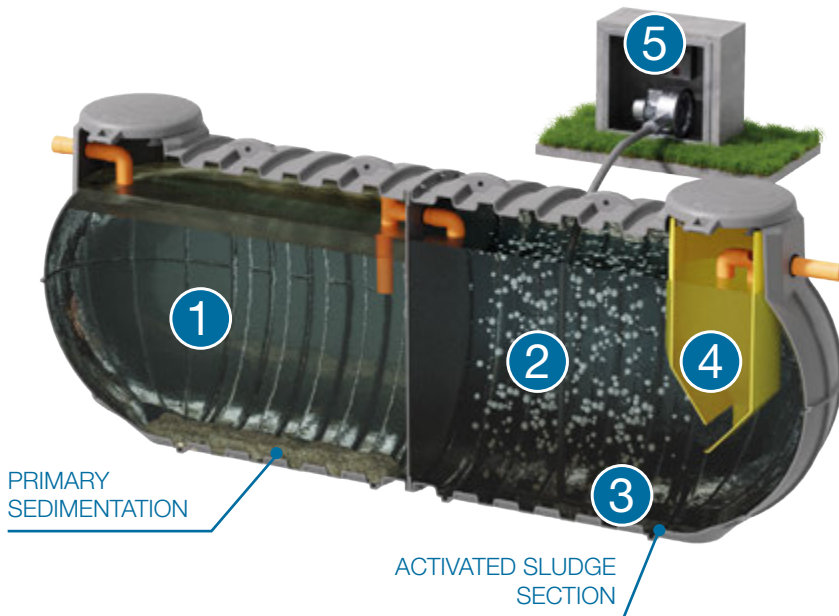

- 1 SEDIMENTATION AND SLUDGE DIGESTION SECTION**
stilling section where the effluent solids settle and accumulate at the bottom of the tank. The bacterial flora transforms the putrescible component of the sludge into inert sludge, carbon dioxide and water.
- 2 OXIDATION SECTION**
zone into which air is blown to move and oxygenate the effluent. This is where the aerobic bacterial flora that oxidises the residual organic component and nitrogen is developed.
- 3 DIFFUSERS**
in microbored rubber for uniform distribution of the air in the oxygenation section.
- 4 FINAL SEDIMENTATION**
stilling zone in which any residual sludge decants and is gravity fed to the oxidation area (only present in INFINITANK models).
- 5 BLOWERS - COMPRESSORS**
to blow air to the oxygenation section diffusers.

INSTALLATION DIAGRAM

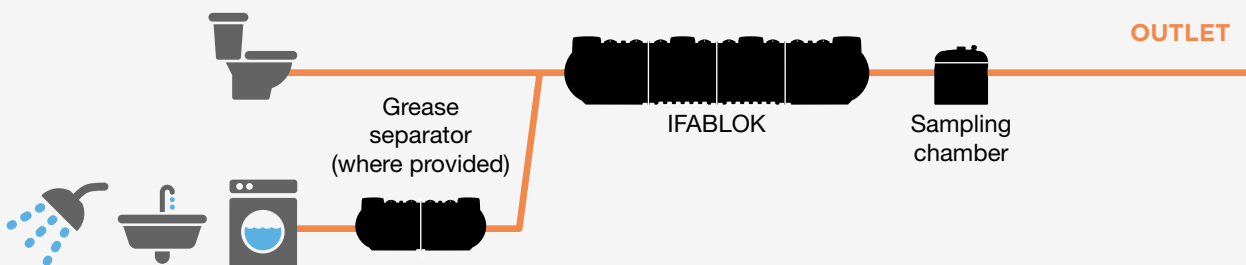

SPECIFICATIONS

DEPURBLOK is the new range of one-piece treatment plants made up of modular tanks for underground installation (Infinitank, Minitank and Nanotank) used to provide a full treatment system for domestic and/or similar sewage (IFABLOK, ANABLOK, BIOBLOK).

TECHNICAL CHARACTERISTICS

The IFABLOK one-piece treatment plant consists of primary sedimentation and anaerobic sludge digestion in a septic tank and subsequent secondary activated sludge aerobic digestion.

IFABLOK is a system that makes use of the action of the aerobic bacterial colonies that, remaining in suspension in the sewage, consume the biodegradable organic material, using it as a nutrient to obtain the necessary energy and the material required for the synthesis of new cells. To guarantee the concentration of oxygen necessary for the development of the biological reaction, an aeration system is used consisting of submerged diffusers which, from the bottom of the tank, disperse a flow of fine air bubbles. This also guarantees sufficient mixing to keep the high concentrations of solids present in the tank in suspension.

USE

Primary and secondary treatment of domestic sewage and similar.

DAILY HYDRAULIC LOAD: 200 l/PE

Please note: it is possible to size the treatment plant according to different daily hydraulic loads.

SEWAGE TREATMENT EFFICIENCY

The IFABLOK one-piece treatment plant (installed as shown in the diagram at page 102) ensures that the concentrations of the final effluent are:

≤160 mg/l
COD

≤40 mg/l
BOD₅

≤80 mg/l
SS

These parameters are respected if the inlet wastewater have the following characteristics (typical concentrations of domestic sewage):

≤600 mg/l
COD

≤300 mg/l
BOD₅

≤400 mg/l
SS

IFABLOK

MODEL

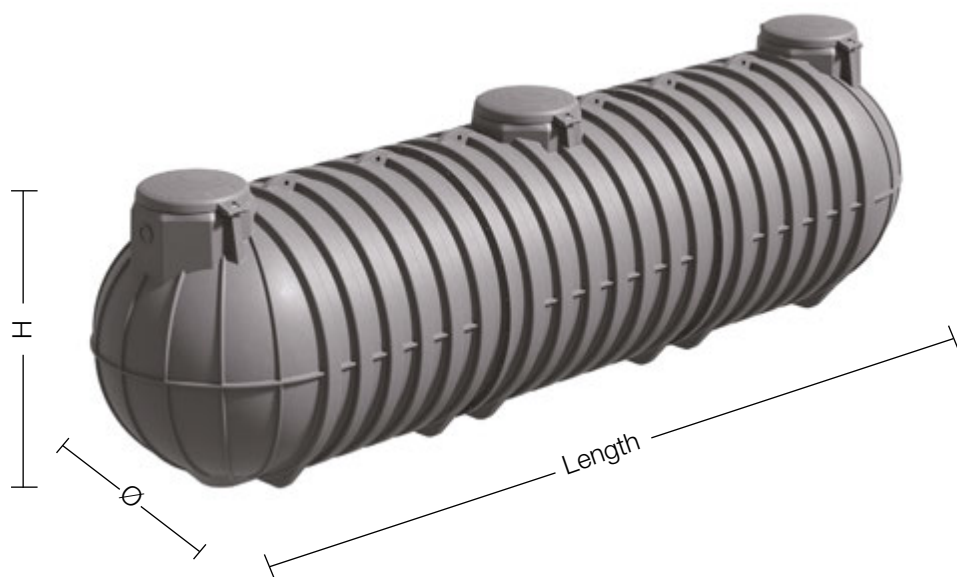

NANOTANK (NT)



MINITANK (MT)



INFINITANK (IT)



IFABLOK

Item	Model	Length mm	Ø mm	H mm	IH mm	OH mm	Ø I/O mm	Ispez. mm	Extension 1 (optional)	Sedimentation Vol. l	Oxidation Vol. l	Blower	PE
NTSEIFA2000	nanotank	2350	1150	1329	960	940	125	2x600	PP77	910	910	HP60	6
NTSEIFA3000	nanotank	2350	1150	1329	960	940	125	2x600	PP77	910	1820	HP80	10
NTSEIFA4000	nanotank	2350	1150	1329	960	940	125	2x600	PP77	1820	1820	HP80	13
NTSEIFA5000	nanotank	2350	1150	1329	960	940	125	2x600	PP77	1820	2730	HP150	16
MTSEIFA6000	minitank	2350	1550	1710	1420	1400	125	2x600	PP77	2780	2780	HP200	20
MTSEIFA9000	minitank	2350	1550	1710	1420	1400	125	2x600	PP77	2780	5560	HP302SF	30
ITSEIFA11000	infinitanak	2350	2100	2200	1870	1850	160	2x600	PP77	5000	5000	HP302SF	35
MTSEIFA12000	minitank	2350	1550	1710	1420	1400	125	2x600	PP77	5560	5560	HP302SF	40
ITSEIFA13000	infinitanak	2350	2100	2200	1870	1850	160	2x600	PP77	5000	7000	HP302SF	45
ITSEIFA15000	infinitanak	2350	2100	2200	1870	1850	160	2x600	PP77	7000	7000	HP302SF	50
ITSEIFA18000	infinitanak	2350	2100	2200	1870	1850	160	2x600	PP77	5000	12000	HP402SF	58
ITSEIFA20000	infinitanak	2350	2100	2200	1870	1850	160	2x600	PP77	7000	12000	HP402SF	65
ITSEIFA22000	infinitanak	2350	2100	2200	1870	1850	160	2x600	PP77	7000	14000	HP402SF	72
ITSEIFA25000	infinitanak	2350	2100	2200	1870	1850	160	2x600	PP77	12000	12000	HP402SF	80
ITSEIFA28000	infinitanak	2350	2100	2200	1870	1850	160	2x600	PP77	12000	14000	HP402SF	90
ITSEIFA30000	infinitanak	2350	2100	2200	1870	1850	160	2x600	PP77	14000	14000	HP402SF	95
ITSEIFA33000	infinitanak	2350	2100	2200	1870	1850	160	2x600	PP77	12000	19000	HP502SF	100
ITSEIFA35000	infinitanak	11790	2100	2200	1870	1850	160	2x600	PP77	12000	21000	HP502SF	110
ITSEIFA36000	infinitanak	12400	2100	2200	1870	1850	160	2x600	PP77	14000	21000	HP402SF	122
ITSEIFA40000	infinitanak	13460	2100	2200	1870	1850	160	2x600	PP77	19000	19000	HP502SF	132



PE. = population equivalent; Ø= diameter; H= height; IH= inlet pipe height; OH= outlet pipe height; ØI/O= inlet/outlet pipe diameter.

ANABLOK

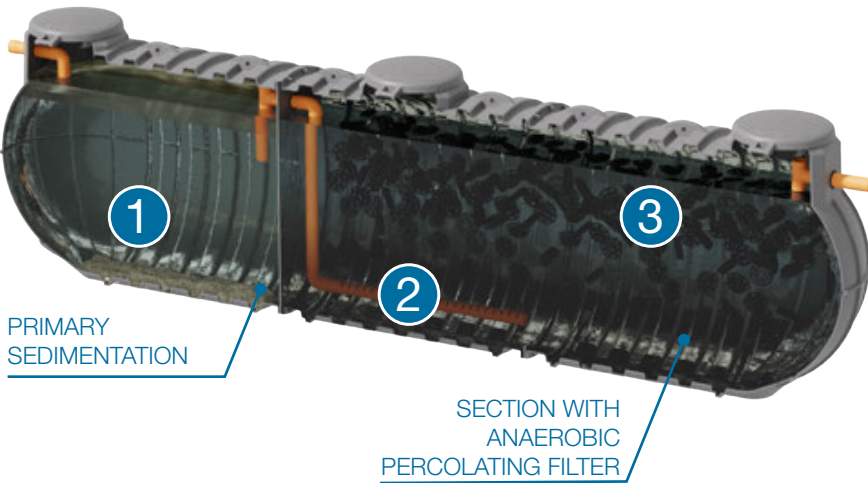

1 SEDIMENTATION AND SLUDGE DIGESTION SECTION

stopping area in which the solid part of the effluent sediments and accumulates on the bottom. This is where a bacterial flora develops that transforms the putrescible material in the sludge into inert sludge, carbon dioxide and water.

2 DISTRIBUTION PIPE

perforated pipe for even distribution of the effluent onto the surface of the filter.

3 FILTER MEDIA

plastic bulk fill material with a large surface area that acts as a support on which the anaerobic bacteria responsible for treating the effluent can develop.

INSTALLATION DIAGRAM



SPECIFICATIONS

DEPURBLOK is the new range of one-piece treatment plants made up of modular tanks for underground installation (Infinitank, Minitank and Nanotank) used to provide a full treatment system for domestic and/or similar sewage (IFABLOK, ANABLOK, BIOBLOK).

TECHNICAL CHARACTERISTICS

The ANABLOK one-piece treatment plant consists of primary sedimentation and anaerobic sludge digestion in a septic tank and subsequent secondary treatment through an anaerobic percolating filter.

ANABLOK is a biological reactor, inside which the micro-organisms that purify the effluent develop on the surface of special bulk fill material (filter media). The uniform distribution of the effluent through the filter guarantees maximum contact between the organic material to purify and the biological film covering the spheres making up the fill material. The filter media is manufactured in polypropylene and is designed to provide a large surface area available for bacterial micro-organisms to take root. This solution minimises the risk of clogging the bed.

USE

Primary and secondary treatment of domestic sewage and similar.

DAILY HYDRAULIC LOAD: 200 l/PE

Please note: it is possible to size the treatment plant according to different daily hydraulic loads.

SEWAGE TREATMENT EFFICIENCY

The ANABLOK one-piece treatment plant (installed as shown in the diagram at page 106) ensures that the concentrations of the final effluent are:

≤160 mg/l
COD

≤40 mg/l
BOD₅

≤80 mg/l
SS

These parameters are respected if the inlet wastewater have the following characteristics (typical concentrations of domestic sewage):

≤600 mg/l
COD

≤300 mg/l
BOD₅

≤400 mg/l
SS

ANABLOK

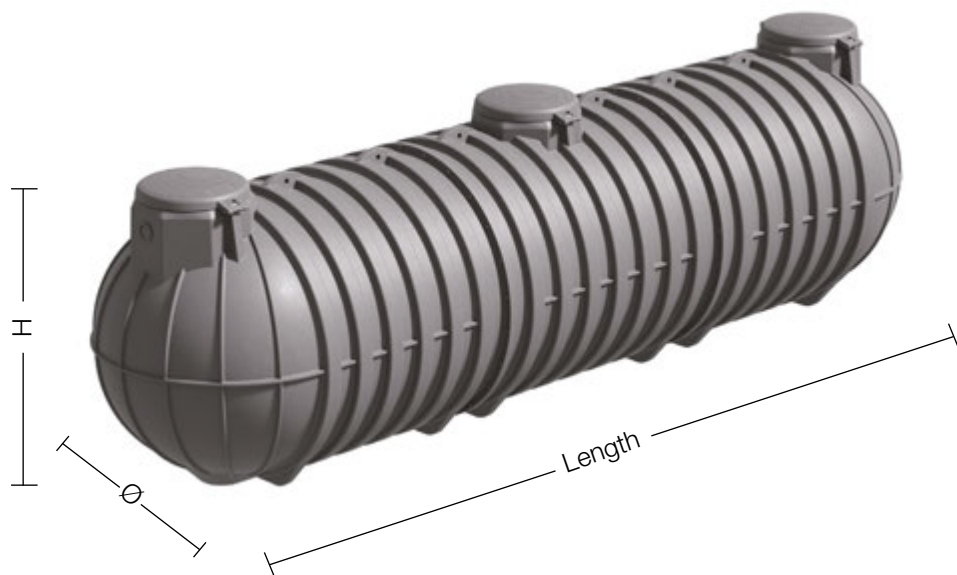

MODEL

NANOTANK (NT)



MINITANK (MT)



INFINITANK (IT)



ANABLOK

Item	Model	Length mm	Ø mm	H mm	IH mm	OH mm	Ø I/O mm	Ispez. mm	Extension 1 (optional)	Sedimentation Vol. l	Filter Vol. l	Filter Surface Area m ²	PE
NTSEAN2000	nanotank	2350	1150	1329	960	940	125	2x600	PP77	910	910	1,4	6
NTSEAN3000	nanotank	3425	1150	1329	960	940	125	2x600	PP77	910	1820	2,8	10
NTSEAN4000	nanotank	4500	1150	1329	960	940	125	2x600	PP77	1820	1820	2,8	13
NTSEAN5000	nanotank	5575	1150	1329	960	940	125	2x600	PP77	1820	2730	4,2	16
MTSEAN6000	minitank	3870	1550	1710	1420	1400	125	2x600	PP77	2780	2780	2,6	20
MTSEAN9000	minitank	5520	1550	1710	1420	1400	125	2x600	PP77	2780	5560	5,2	30
ITSEAN11000	infinitanak	4420	2100	2200	1870	1850	160	2x600	PP77	5000	5000	4,2	35
MTSEAN12000	minitank	7180	1550	1710	1420	1400	125	2x600	PP77	5560	5560	5,2	40
ITSEAN13000	infinitanak	5010	2100	2200	1870	1850	160	2x600	PP77	5000	7000	5,2	45
ITSEAN15000	infinitanak	5620	2100	2200	1870	1850	160	2x600	PP77	7000	7000	5,1	50
ITSEAN18000	infinitanak	6680	2100	2200	1870	1850	160	2x600	PP77	5000	12000	9,3	58
ITSEAN20000	infinitanak	7270	2100	2200	1870	1850	160	2x600	PP77	7000	12000	9,3	65
ITSEAN22000	infinitanak	7880	2100	2200	1870	1850	160	2x600	PP77	7000	14000	10,2	72
ITSEAN25000	infinitanak	8940	2100	2200	1870	1850	160	2x600	PP77	12000	12000	9,3	80
ITSEAN28000	infinitanak	9530	2100	2200	1870	1850	160	2x600	PP77	12000	14000	10,2	90
ITSEAN30000	infinitanak	101400	2100	2200	1870	1850	160	2x600	PP77	14000	14000	10,2	95
ITSEAN33000	infinitanak	11200	2100	2200	1870	1850	160	2x600	PP77	12000	19000	14,4	100
ITSEAN35000	infinitanak	11790	2100	2200	1870	1850	160	2x600	PP77	12000	21000	15,3	110
ITSEAN36000	infinitanak	12400	2100	2200	1870	1850	160	2x600	PP77	14000	21000	15,3	122
ITSEAN40000	infinitanak	13460	2100	2200	1870	1850	160	2x600	PP77	19000	19000	14,4	132



PE. = population equivalent; Ø= diameter; H= height; IH= inlet pipe height; OH= outlet pipe height; ØI/O= inlet/outlet pipe diameter.

BIOBLOK

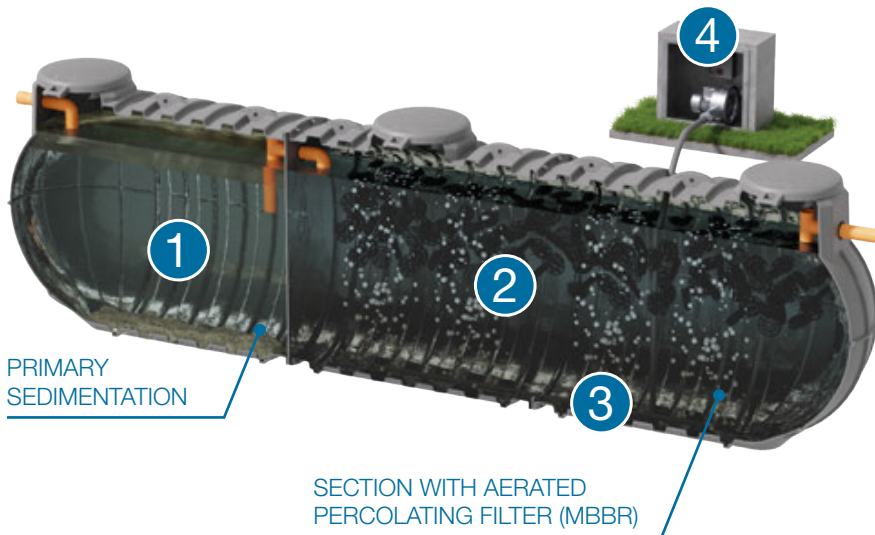

1 SEDIMENTATION AND SLUDGE DIGESTION SECTION

stilling section where the effluent solids settle and accumulate at the bottom of the tank. The bacterial flora transforms the putrescible component of the sludge into inert sludge, carbon dioxide and water.

2 FILTER MEDIA

plastic bulk fill material with a large surface area that acts as a support on which the aerobic bacteria responsible for treating the effluent can develop

3 DIFFUSERS

in microbored rubber for uniform distribution of the air in the oxygenation section.

4 BLOWERS - COMPRESSORS

to blow air to the oxygenation section diffusers.

INSTALLATION DIAGRAM



SPECIFICATIONS

DEPURBLOK is the new range of one-piece treatment plants made up of modular tanks for underground installation (Infinitank, Minitank and Nanotank) used to provide a full treatment system for domestic and/or similar sewage (IFABLOK, ANABLOK, BIOBLOK).

TECHNICAL CHARACTERISTICS

The BIOBLOK one-piece treatment plant consists of primary sedimentation and anaerobic sludge digestion in a septic tank and subsequent secondary adhered biomass aerobic digestion.

BIOBLOK is a biological reactor, more specifically it's a Moving Bed Biofilm Reactor (MBBR), inside which the micro-organisms that purify the effluent develop on the surface of special bulk fill material (filter media). The uniform distribution of the effluent through the filter guarantees maximum contact between the organic material to purify and the biological film covering the spheres making up the fill material. More specifically, the bacteria that grows and develops inside the aerobic percolating filter with top outlet consumes the organic load in the effluent in the presence of oxygen. The oxygen enters the tank continuously through the external compressor and is distributed by the diffuser plates.

USE

Primary and secondary treatment of domestic sewage and similar.

DAILY HYDRAULIC LOAD: 200 l/PE

Please note: it is possible to size the treatment plant according to different daily hydraulic loads.

SEWAGE TREATMENT EFFICIENCY

The BIOBLOK one-piece treatment plant (installed as shown in the diagram at page 110) ensures that the concentrations of the final effluent are:

≤160 mg/l
COD

≤40 mg/l
BOD₅

≤80 mg/l
SS

But also ensures these final concentration according to the number of PE indicated in PE T4 column of the table at page __

≤100 mg/l
COD

≤20 mg/l
BOD₅

≤25 mg/l
SS

All these parameters are respected if the inlet wastewater have the following characteristics (typical concentrations of domestic sewage):

≤600 mg/l
COD

≤300 mg/l
BOD₅

≤400 mg/l
SS

BIOBLOK

MODEL



NANOTANK (NT)



MINITANK (MT)



INFINITANK (IT)

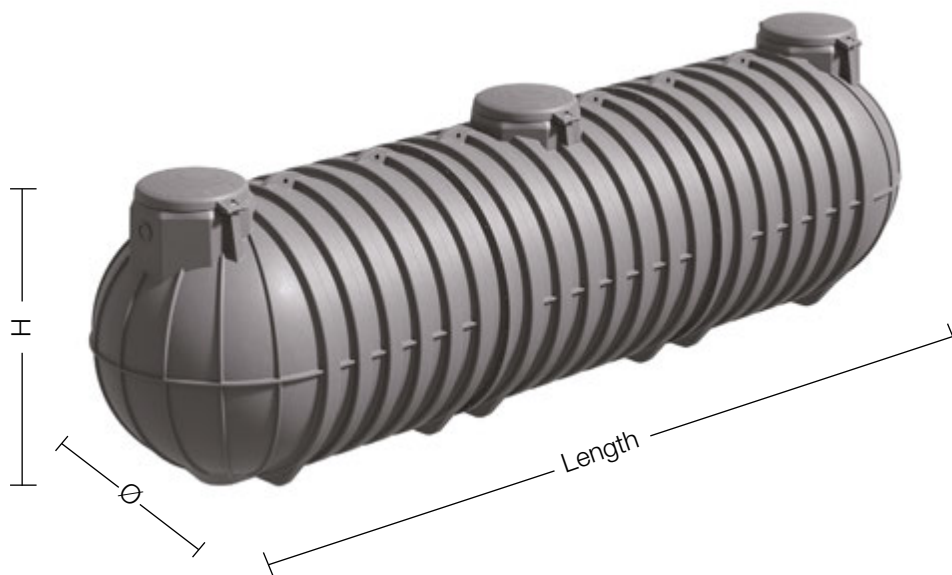

BIOBLOK

Item	Model	Length mm	Ø mm	H mm	IH mm	OH mm	Ø I/O mm	Ispez. mm	Extension 1 (optional)	Sedimentation Vol. l	Filter Vol. l	Blower	PE	PE T4
NTSEARA2000	nanotank	2350	1150	1329	960	940	125	2x600	PP77	910	910	HP60	6	4
NTSEARA3000	nanotank	3425	1150	1329	960	940	125	2x600	PP77	910	1820	HP80	10	7
NTSEARA4000	nanotank	4500	1150	1329	960	940	125	2x600	PP77	1820	1820	HP80	14	10
NTSEARA5000	nanotank	5575	1150	1329	960	940	125	2x600	PP77	1820	2730	HP150	18	13
MTSEARA6000	minitank	3870	1550	1710	1420	1400	125	2x600	PP77	2780	2780	HP200	24	16
MTSEARA9000	minitank	5520	1550	1710	1420	1400	125	2x600	PP77	2780	5560	HP302SF	35	23
ITSEARA11000	infinitank	4420	2100	2200	1870	1850	160	2x600	PP77	5000	5000	HP302SF	40	27
MTSEARA12000	minitank	7180	1550	1710	1420	1400	125	2x600	PP77	5560	5560	HP302SF	46	30
ITSEARA13000	infinitank	5010	2100	2200	1870	1850	160	2x600	PP77	5000	7000	HP302SF	50	35
ITSEARA15000	infinitank	5620	2100	2200	1870	1850	160	2x600	PP77	7000	7000	HP302SF	58	38
ITSEARA18000	infinitank	6680	2100	2200	1870	1850	160	2x600	PP77	5000	12000	HP402SF	65	45
ITSEARA20000	infinitank	7270	2100	2200	1870	1850	160	2x600	PP77	7000	12000	HP402SF	75	50
ITSEARA22000	infinitank	7880	2100	2200	1870	1850	160	2x600	PP77	7000	14000	HP402SF	80	56
ITSEARA25000	infinitank	8940	2100	2200	1870	1850	160	2x600	PP77	12000	12000	HP402SF	90	60
ITSEARA28000	infinitank	9530	2100	2200	1870	1850	160	2x600	PP77	12000	14000	HP402SF	100	70
ITSEARA30000	infinitank	10140	2100	2200	1870	1850	160	2x600	PP77	14000	14000	HP402SF	110	74
ITSEARA33000	infinitank	11200	2100	2200	1870	1850	160	2x600	PP77	12000	19000	HP502SF	122	80
ITSEARA35000	infinitank	11790	2100	2200	1870	1850	160	2x600	PP77	12000	21000	HP502SF	132	90
ITSEARA36000	infinitank	12400	2100	2200	1870	1850	160	2x600	PP77	14000	21000	HP402SF	140	100
ITSEARA40000	infinitank	13460	2100	2200	1870	1850	160	2x600	PP77	19000	19000	HP502SF	150	112



PE. = population equivalent; Ø= diameter; H= height; IH= inlet pipe height; OH= outlet pipe height; ØI/O= inlet/outlet pipe diameter.

TECHNICAL SECTION – DEPURBLOK

TECHNICAL CHARACTERISTICS – PRIMARY SEDIMENTATION

Septic tanks constitute a reliable device for the primary treatment of sewage. The treatment systems are passive, extremely stable, simple and inexpensive. They are used, above all, for treating domestic sewage from small communities. The configuration of the tank forces the sewage to pass through the liquid mass contained in it. The slowing down of the flow allows sedimentable solids and substances of specific weight less than that of the water to separate. Furthermore, an anaerobic fermentation process is triggered with the resulting **solubilisation and synthesis of part of the suspended solids**. In this way, the effluent leaving the tank is conditioned, i.e. it has a limited concentration of solids, transformed for the most part into dissolved and colloidal solids.

Septic tanks are nothing more than **stilling tanks** in which the following processes take place:

- **separation** of sedimentable solids, coarse material, sands/grits, oils and greases present in the sewage;
- reduction of a fraction of the accumulated organic substances by **decomposition**;
- accumulation and prolonged **storage** of the separated materials.

Compartmentation, i.e. the division of the system into chambers, significantly influences the efficiency of the treatment process. With this configuration, a large part of the suspended solids accumulate in the first compartment and only pass to the next chamber with great difficulty. Compartmentation is particularly effective when high levels of treatment are to be reached, particularly in terms of reducing suspended solids. Septic tanks are sized to achieve a high purification performance and to obtain liquefaction of the sludge, reducing its formation and thus minimising disposal costs.

USE AND MAINTENANCE – PRIMARY SEDIMENTATION

An excessive accumulation of putrescible material at the bottom of the tank can cause **uncontrolled anaerobic digestion** phenomena, leading to an over-production of biogas and the development of malodorous emissions. Furthermore, the reduction in the volume available in the digestion compartment and the excessive production of gas bubbles will cause the settled material to rise, thus causing **deterioration** in the quality of the treated effluent.

For this reason, according to the loads feeding the tank, between 1 and 4 inspections a year are to be carried out, with removal of the sludge if necessary. It is sometimes recommended not to remove all the deposited sludge, but to **leave approximately 1/10 of the sludge** that has deposited in the tank; this accelerates re-start of the processes. The use of the Rototec Bio-activator is highly recommended to trigger the biological processes more quickly, thus limiting the number of sludge removal operations and reducing the risk of bad smells.

MANAGEMENT – PRIMARY SEDIMENTATION

WHAT TO DO	WHEN	HOW
Inspect the septic tank	From 1 to 4 times a year	Unscrew the inspection covers and check the level of sediments
Remove the settled sludge, clean the interior and the inlet and outlet pipes	Every 6 / 12 months	Contact a licensed waste disposal company

N.B. the frequency of operations will depend on the incoming organic load.

PROHIBITIONS

- **do not use toxic and/or poisonous substances** (bleach, solvents, insecticides, disinfectant substances, aggressive detergents), always use biodegradable products;
- **NEVER** flush paper tissues, kitchen towel, paper napkins or other materials except toilet paper down the toilet;
- **NEVER** allow rainwater to enter the system.

WARNINGS

- make sure that drains have a siphon;
- check that the pipes slope sufficiently (approximately 1% - 2%);
- connect the biogas vent pipe (**see underground installation**);
- after emptying, fill the tank again with **clean water**;
- in the event of a maintenance operation of any kind, always comply with the **safety regulations** regarding operations within enclosed wastewater treatment areas and with the general technical procedures applicable.
- make sure that drains have a siphon;

TECHNICAL SECTION – DEPURBLOK

TECHNICAL CHARACTERISTICS – ACTIVATED SLUDGE SECTION

Activated sludge plants are secondary treatment systems that make use of the action of the bacterial colonies that, remaining in suspension in the effluent, consume the biodegradable organic material, using it as a nutrient to obtain the necessary energy and the material required for the synthesis of new cells. In this manner, increasingly stable compounds are formed leading to the total degradation of the organic load. Very high concentrations of aerobic type bacteria are developed inside activated sludge plants, sufficient, that is, to absorb the dissolved oxygen in the water in order to consume the biodegradable material. To guarantee the concentration of oxygen necessary for the development of the biological reaction, an aeration system is adopted consisting of submerged diffusers which, from the bottom of the tank, disperse a flow of fine air bubbles. This also guarantees sufficient mixing to keep the high concentrations of solids present in the tank in suspension.

In the oxygen rich environment of the aeration tank, a number of different processes are set in motion:

- **Chemical**, i.e. the oxidation of malodorous compounds (hydrogen sulphide, sulphites...)
- **Physical**, i.e. the removal of effluent solids trapped by the dispersion of bacteria
- **Biological**, i.e. direct assimilation of the organic substances dissolved in the sewage.

The sizing of the activated sludge plants is performed on the basis of the **sludge load** (or organic load factor) expressed as the ratio between the organic load BOD_5 and the micro-organisms; the lower this ratio, the more intensely the organic load is consumed, at the same time reducing the production of excess sludge. Rototec activated sludge plants are sized to have sludge loads of less than 0.08 KgBOD / KgSSD with retention times of more than 24 hours at mean flows and volumetric loads of less than 0.25 KgBOD / m³d in the prolonged aeration (or total oxidation) configuration and sludge loads of less than 0.15 KgBOD/KgSSD and volumetric loads less than 0.5 KgBOD / m³d in the low-load configuration.

USE AND MAINTENANCE – ACTIVATED SLUDGE SECTION

The small user activated sludge plant is designed with the sedimentation compartment inside the oxidation tank in order to provide sewage settlement as well as sludge recirculation. This however leads to a build-up of solids in the oxidation chamber. It should be remembered that in order to ensure the correct operation of an activated sludge plant, a grease separator should be installed upstream of the reactor itself, and that the aeration should be kept on during the periods of use of the plant. The plant needs 10-15 days in order to reach normal operation. This time can be reduced however by adding biomass activators (Rototec bio activator) directly to the sewage.

MANAGEMENT – ACTIVATED SLUDGE SECTION

WHAT TO DO	WHEN	HOW
Inspect the activated sludge plant	Every 6 / 12 months	Unscrew the covers on the inspection holes and check the level of sediments
Check operation of the blower	Every month	Unfasten the inlet inspection hole cover and check that air is being blown in
Extract the bottom sludge, clean the interior, the inlet and outlet pipes and the diffuser plate	Every 6 / 12 months	Contact a licensed waste disposal company
Change the chlorine tablet	Every 2 months	Unfasten the outlet inspection hole cover and insert the tablet in the housing provided

N.B. the frequency of operations will depend on the incoming organic load.

PROHIBITIONS

- **do not use toxic and/or poisonous substances** (bleach, solvents, insecticides, disinfectant substances, aggressive detergents), always use biodegradable products;
- **NEVER** put the chlorine tablet into the plant, but insert it in the proper housing;
- **NEVER** drain rainwater into the system.

WARNINGS

- make sure that drains have a siphon;
- check that the pipes slope sufficiently (approximately 1% - 2%);
- connect the biogas vent pipe (**see installation method**);
- when discharging into the subsoil using a soil absorption system, provide a dosing siphon chamber downstream of the system, for better distribution of the effluent into the dispersion pipes;
- after pump-out, fill the tank again with **clean water**;
- in the event of a maintenance operation of any kind, always comply with the **safety regulations** regarding operations within closed waste water treatment areas, and with the general technical procedures applicable.

TECHNICAL SECTION – DEPURBLOK

TECHNICAL CHARACTERISTICS – SECTION WITH ANAEROBIC PERCOLATING FILTER

A trickle filter is a biological reactor, inside which the micro-organisms that purify the effluent develop on the surface of **special bulk fill material (filter media)**. The uniform distribution of the effluent through the filter guarantees maximum contact between the organic material to purify and the biological film covering the spheres making up the fill material. The spheres making up the filter media are manufactured in polypropylene and are designed to provide a large surface area available for bacterial micro-organisms to take root. In particular, the spheres used provide a **surface area per unit volume of filter media of 140 m²/m³**, much higher than the traditional stone fill material, with **voids accounting for over 90%**. This solution minimises the risk of clogging the bed and also guarantees an improved circulation of air through the bed of the aerobic filter. Trickle filters allow good purification performance **without any energy overheads**, with management costs limited to the occasional cleaning of the plant.

The sizing of percolating filters for an average domestic effluent refers to the organic load factor kgBOD/m³d with which the filter is fed. This parameter is the ratio between the organic load at the inlet kg BOD₅d and the volume of the filter bed. Rototec trickle filters are designed to operate with medium-low organic load factors kg BOD₅ / m³d. This guarantees a good margin of safety, with respect to fluctuations in inlet flow, and a limited production of excess sludge.

USE AND MAINTENANCE – SECTION WITH ANAEROBIC PERCOLATING FILTER

The filter is designed to ensure **minimum clogging risk**. However, the development of the films on the filter media can over time excessively dirty the filter, with the resulting risk of solids being discharged with the treated effluent.

Cleaning operations are normally carried out as part of the Imhoff tank inspection and emptying operations. It should be remembered that in order for the trickle filter to function correctly, the effluent must first be subjected to sedimentation treatment in an Imhoff tank or similar installed upstream of the filter. The use of Rototec Bio-Activators is recommended for rendering the starting of the biological processes more rapid.

MANAGEMENT – SECTION WITH ANAEROBIC PERCOLATING FILTER

WHAT TO DO	WHEN	HOW
Inspect the trickle filter	Every 12 months	Unscrew the covers on the inspection holes and check the level of sediments
Extract the bottom sludge, clean the interior and the inlet and outlet pipes and backwash the filter media	Every 12 / 15 months	Contact a licensed waste disposal company

N.B. the frequency of operations will depend on the incoming organic load.

PROHIBITIONS

- **do not use toxic and/or poisonous substances** (bleach, solvents, insecticides, disinfectant substances, aggressive detergents); always use biodegradable products;
- **NEVER** drain rainwater into the system.

WARNINGS

- make sure that drains have a siphon;
- check that the pipes slope sufficiently (approximately 1% - 2%);
- connect the biogas vent pipe (**see installation method**).
- **when discharging to a surface watercourse**, install a septic tank (Imhoff or other septic tank) downstream of the trickle filter as the final effluent sedimentation and clarification phase;
- when discharging into the subsoil using a soil absorption system, provide a **dosing siphon chamber** downstream of the system, for better distribution of the effluent into the dispersion pipes;
- after pump-out, fill the tank again with **clean water**;
- in the event of a maintenance operation of any kind, always comply with the **safety regulations** regarding operations within closed waste water treatment areas, and with the general technical procedures applicable.

DEPURBLOK ACCESSORIES (INCLUDED IN THE SUPPLY-IFABLOK-BIOBLOK)



SIDE CHANNEL COMPRESSORS/BLOWERS

construction of the ring blowers fan is based on the lateral ducts principle. The blowers can operate as either exhaust or compression fans and are designed for continuous service. The device is assembled directly on the motor shaft: all rotating parts are dynamically balanced to ensure absolute absence of vibration. Full die-cast aluminium construction for maximum sturdiness and ease of handling.

USE AND MAINTENANCE

the blower does not have any moving parts in contact, and as such does not require lubrication, its operation is long-term and does not require any other maintenance. It should, however, be installed in a suitable cabinet by qualified personnel.

BLOWER TIMING

- the blower must remain switched on **24h a day for the first 2-3 months** in order to activate the purification processes;
- after the activation period, blower operation can be timed as follows: **2 hours ON-30 minutes OFF** (repeated for all 24 hour periods)

Item	Voltage V	Frequency Hz	Power W	Absorption (A)	Noise level (dBa)	Weight (kg)	Length (mm)	Width (mm)	Height (mm)
HP302SF	220	50	0.7	4.5	< 55	15	458	316	270
HP302SF	380	50	1.6	5.6	< 66	24	485	401	315
HP302SF	380	50	3	10	< 72	38	597	465	371

HP302SF

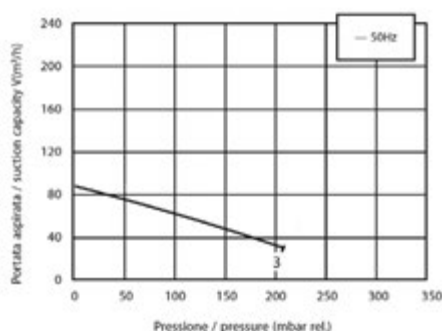

HP402SF

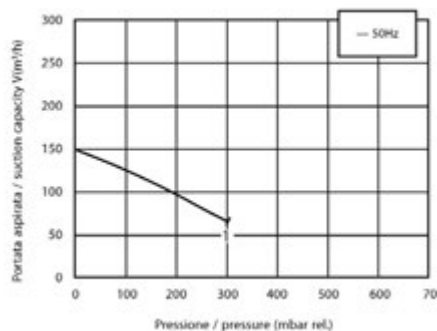

HP502SF

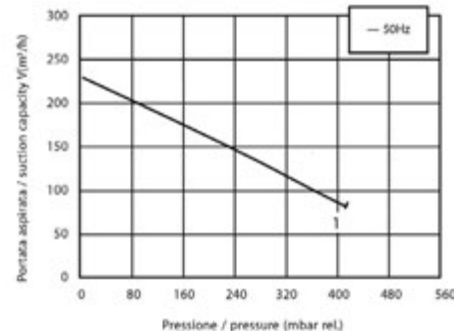

DEPURBLOK ACCESSORIES (INCLUDED IN THE SUPPLY-IFABLOK-BIOBLOK)

PIPE DIFFUSERS

The pipe diffusers allow the air various passages, avoiding loss of load and guaranteeing an even distribution of oxygen at balanced concentrations throughout the tank, to optimise treatment in the oxidation system.

The micro-pores present all over the surface act like a valve. When they dilate the air comes out, otherwise, when the flow stops, they close and prevent the water from returning.



PIPE DIFFUSERS

Item	Ø mm	Length mm	Ø Bubbles mm	Capacity m³/h	Working temperature limit	Weight kg	Diaphragm material	Clip material
IFADNT600	60	300	1-3	5.1-15.3	From 0° to 120°C	0.9	Silicone	304 stainless steel

Application: micro-pore pipe diffusers used in oxidation plants, created to give even air distribution that optimises the system's treatment performance. The micro-pores act like a valve. When they dilate the air comes out, otherwise, when the flow stops, they close and prevent the water from returning.

INSTALLATION

- already fitted inside the tank and connected to the set-up provided;
- stays on the bottom of the tank thanks to its special micro-pore rubber structure.

MANAGEMENT

WHAT TO DO	WHEN	HOW
Clean the diffuser plate	During pump-out of the plant (every 6/12 months)	Contact a licensed waste disposal company (water jet pump-out)

WARNINGS

- during cleaning operations, lift the plate using the transparent pipe provided, paying attention to the set-up in the tank.

MEMBRANE AIR DIFFUSERS

rubber surface with microholes that act like one valve, dilating themselves in order to let out the air but closing up once the flow is interrupted preventing to the water to enter



APPLICATIONS

- Wastewater treatment
- Intermittent operation capability
- Clean water treatment
- Sludge stabilization
- Aeration of fish pond, streams and lakes

USE AND MAINTENANCE

the particular structure of the plates reduces the risk of blockages even during intermittent operation to a minimum and eliminates the possibility of its separation during the inspection phase, thus guaranteeing a high air flow with minimum head loss. The rubber lining of the rigid air distributor provides protection against accidental damage to the system, which will maintain its original characteristics over time. During the cleaning operations of the oxidation plant, clean the membrane air diffusers with water to avoid any clogging of the bored surface.

Item	Material	Diameter mm	Size and quantity of the bubbles	Connection	Air flow	Operation temperature	Diffusion area
IFADN250	High grade EPDM hardness 60° ±5	250	1-3 mm 8300 holes	R ¾" NPT	1,5-8,5 m³/h	0 – 100 °C	1,67 m

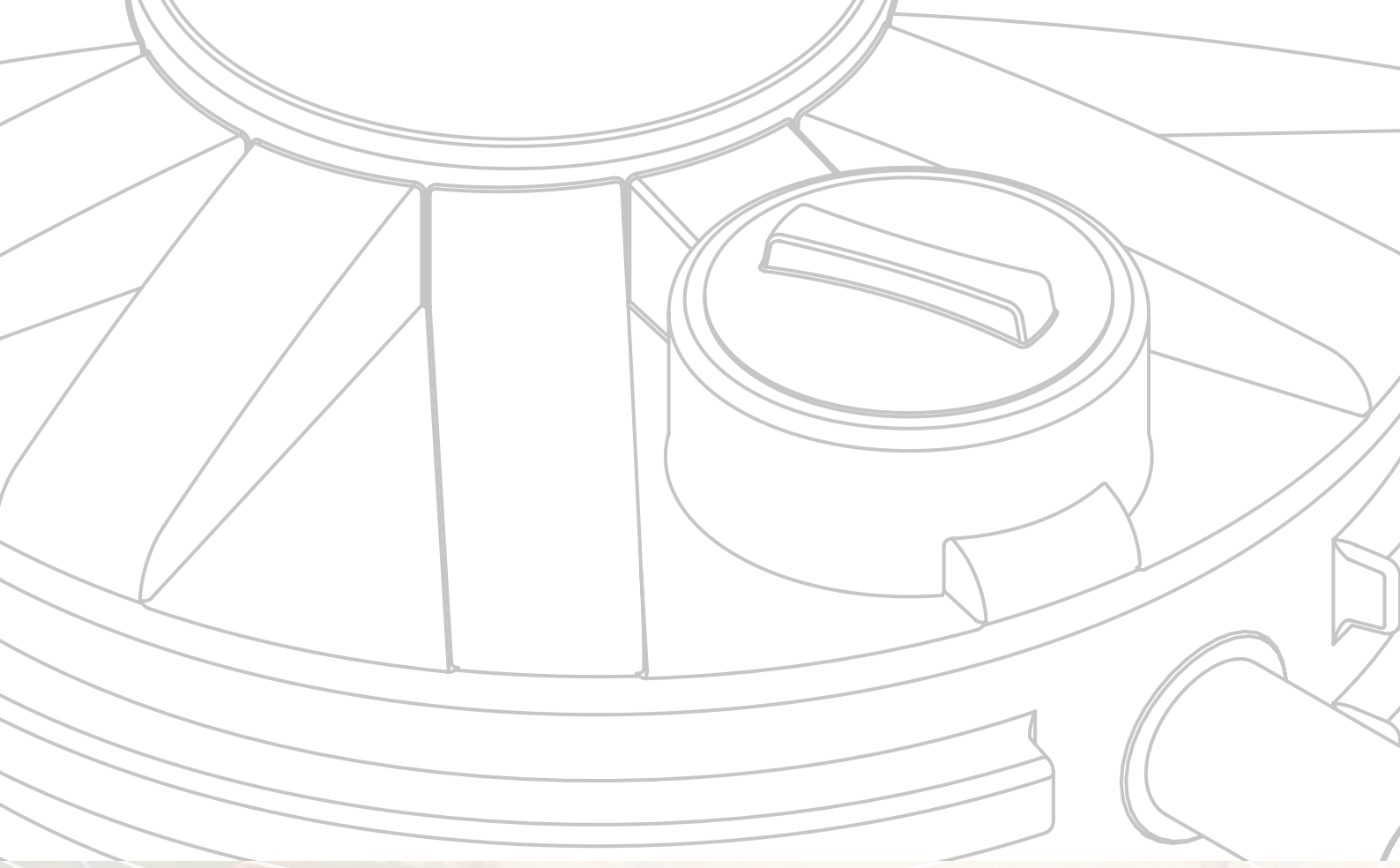

GRIT SEPARATORS



GRIT SEPARATORS



- 1 **STILLING ZONE**
zone through which the separated and treated effluent flows.
- 2 **SEDIMENTS**
area for the temporary accumulation of solids (stones, sand/grit, leaves, twigs, etc...).

INSTALLATION DIAGRAM

Covered or uncovered
hardstanding



Grit separator



OUTLET



SPECIFICATIONS

TECHNICAL CHARACTERISTICS

Grit removal is a mechanical pretreatment that removes all substances of specific weight higher than water (stones, sand/grit, leaves, etc.) running off from covered and uncovered surfaces (roads, car parks, warehouse hardstandings, etc.) and wash areas.

The grit separator is a settling tank in which the velocity of the fluid is reduced, allowing suspended solids to settle and accumulate at the bottom of the tank.

USE

Primary treatment of runoff and rainwater from exposed surfaces, hardstandings, car parks, industrial areas, service stations, etc.

REFERENCE STANDARDS

UNI EN 858-1

UNI EN 858-2

Item	Ø mm	H mm	IH mm	OH mm	Ø I/O mm	Cover 1	Cover 2	Extension 1 (optional)	Extension 2 (optional)	Useful Vol. l	NS l/s	Covered hardstanding m ²	Uncovered hardstanding m ²
NDS1000	1150	1220	870	850	125	CC400	CC200	PP45	PP30	836	3	1350	540
NDS1500	1150	1720	1350	1330	125	CC400	CC200	PP45	PP30	1254	5	2250	900
NDS2100	1350	1975	1530	1510	125	CC400	CC300	PP45	PP35	1932	6	2700	1080
NDS2600	1710	1450	970	950	160	CC400	CC300	PP45	PP35	1986	8	3600	1440
NDS3200	1710	1725	1210	1190	160	CC400	CC300	PP45	PP35	2450	10	4500	1800
NDS3800	1710	1955	1410	1390	200	CC400	CC300	PP45	PP35	3015	15	6750	2700
NDS4600	1710	2225	1670	1650	200	CC400	CC300	PP45	PP35	3675	20	9000	3600
NDS5400	1950	2250	1600	1580	250	CC400	CC400	PP45	PP45	4320	24	10800	4320
NDS6400	1950	2530	1870	1850	250	CC400	CC400	PP45	PP45	5035	28	12600	5040
NDS7000	2250	2367	1720	1700	315	CC400	CC400	PP45	PP45	6399	35	15750	6300
NDS9000	2250	2625	1970	1950	315	CC400	CC400	PP45	PP45	7288	40	18000	7200

Ø= diameter; H= height; IH= inlet pipe height; OH= outlet pipe height; ØI/O= inlet/outlet pipe diameter; NS= limit flow rate (l/s).

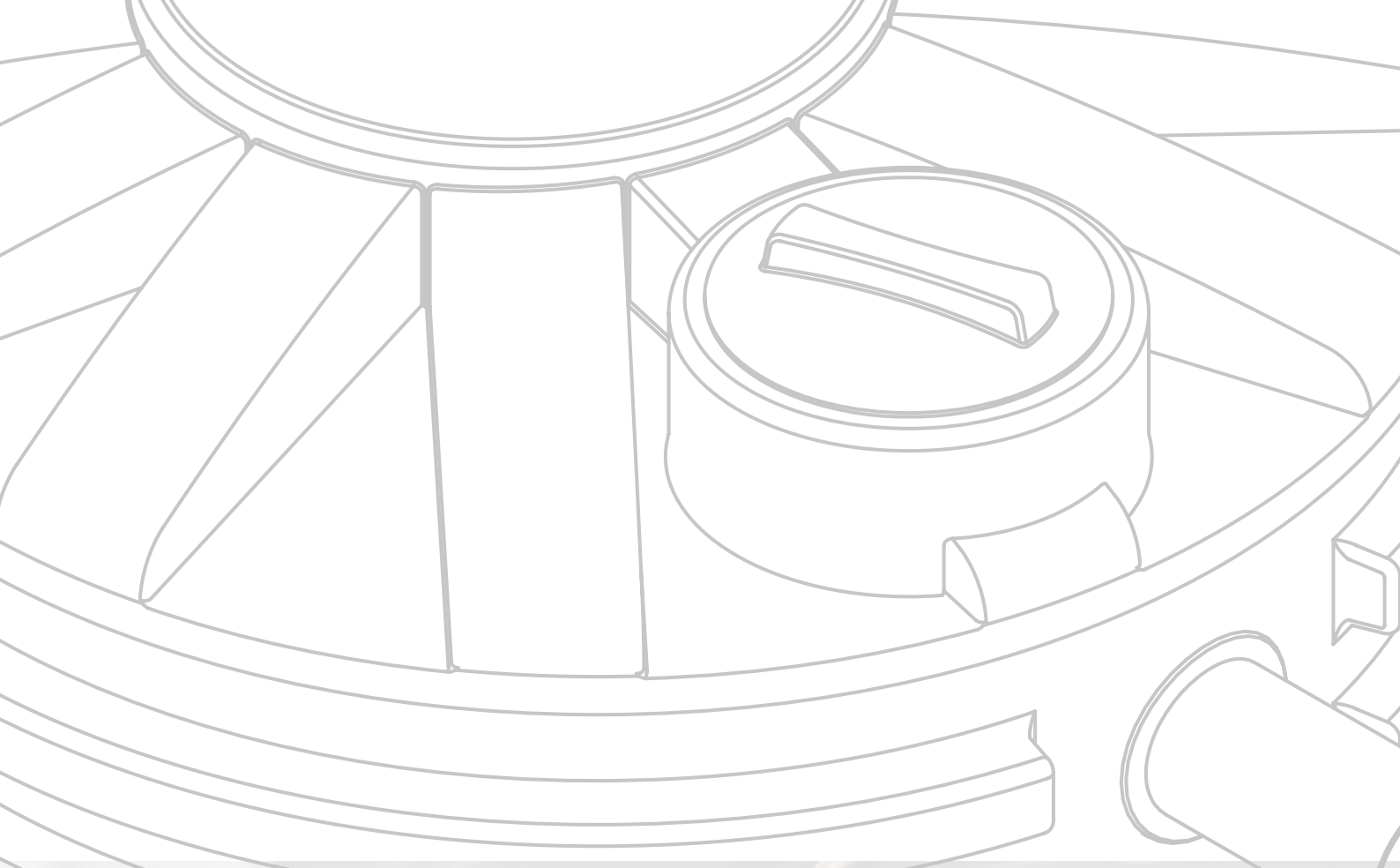

COALESCING FILTER TYPE OIL SEPARATORS

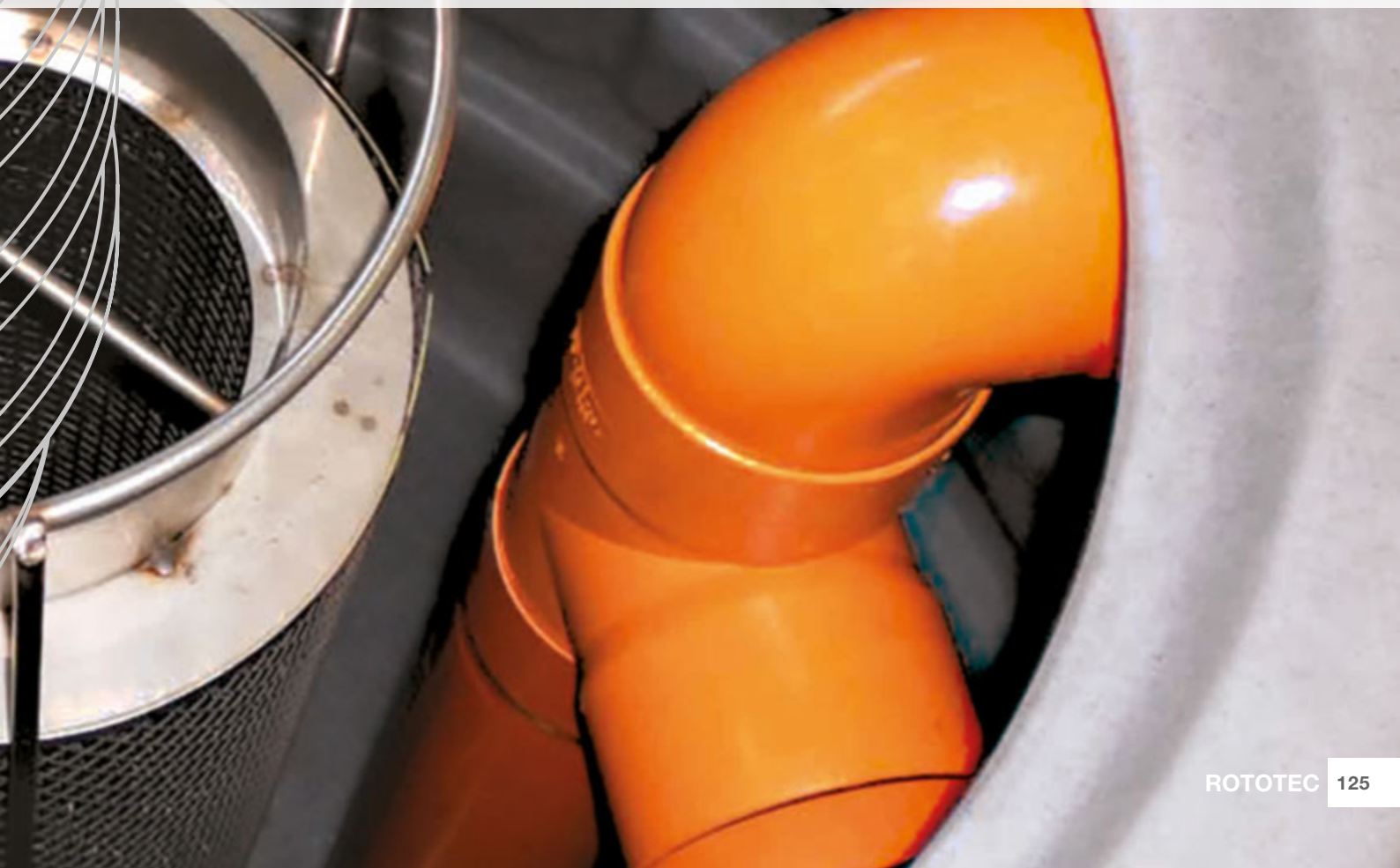

OIL SEPARATORS

COALESCING FILTER TYPE

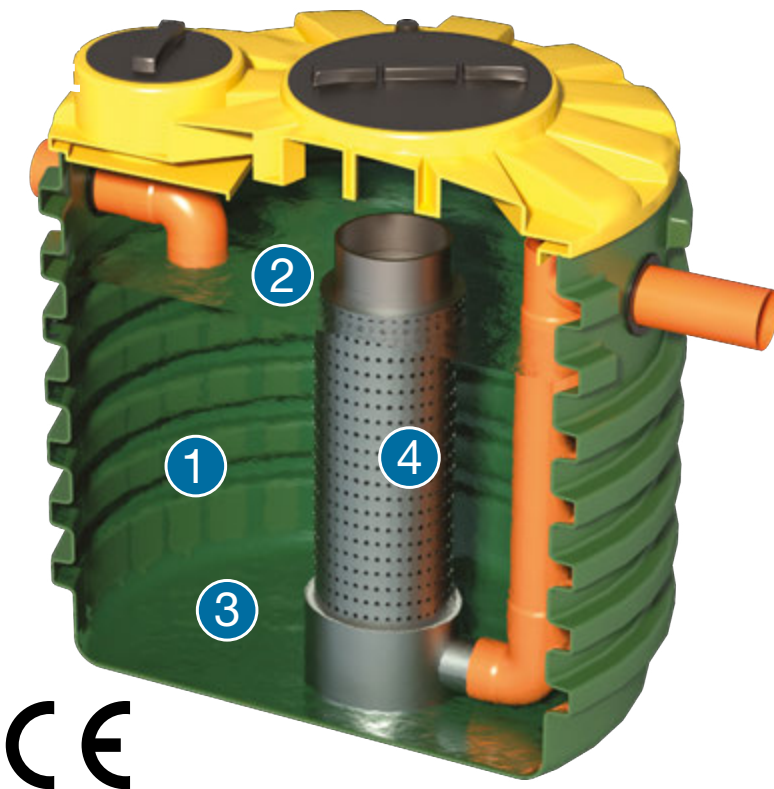

- 1 SEPARATION AREA**
 stilling area in which floating substances such as oil, grease and any foam are separated from the effluent and accumulate on the surface, while the heavy substances (stones, grit, pieces of rubber and metal,...) settle on the bottom of the tank.
- 2 OIL ACCUMULATION AREA**
 the oils separated from the effluent accumulate on the surface.
- 3 HEAVY SEDIMENT ACCUMULATION AREA**
 the heavy materials separated from the effluent accumulate on the bottom of the tank.
- 4 COALESCING FILTER**
 fine micro-bubble polyurethane filter inserted into a stainless steel grid, which can be extracted thanks to the presence of a base and guides, also made of stainless steel. The coalescing filter is able to join the fine particles of oil present in the effluent into larger drops that are large enough to migrate towards the surface, separating from the effluent.

INSTALLATION DIAGRAM

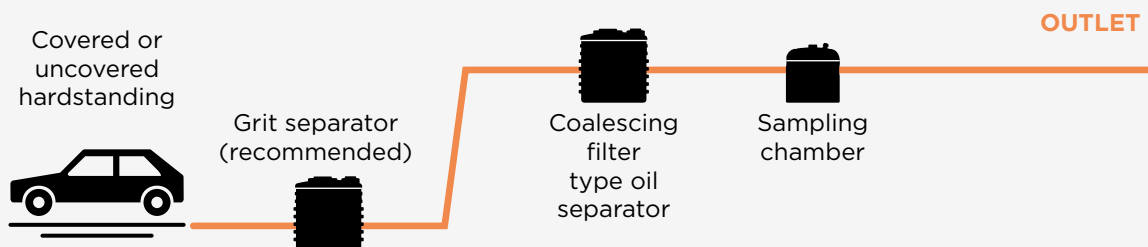

SPECIFICATIONS

TECHNICAL CHARACTERISTICS

The oil separators with coalescing filters allow improved performance to be obtained in removing light substances. The system makes use of a polyurethane sponge support on which the oil and hydrocarbon particles collect until their dimensions are such that enable them to settle away from the effluent by gravity. This treatment is recommended in the presence of particularly severe limitations on the discharged concentrations of mineral oils and hydrocarbons. It is advisable to install a grit separator upstream of the oil separator in order to prevent solid particles from clogging the filter meshes.

USE

Treatment of surface drainage water from covered and open-air hardstandings, car parks, car showrooms, garages.

PRODUCT CERTIFICATION

The Rototec oil separators with coalescing filter (excluding the modular range) are CE marked and have been designed, tested and certified under UNI EN 858-1 "Separator systems for light liquids (e.g. oil and petrol). Part 1: Principles of design, performance and product testing, marking and quality control".

The oil separators with coalescing filter have been verified and tested at Rototec and by a third party certifying body, and have been found to comply with the necessary requirements.

- Watertightness
- Structural stability
- Nominal capacity
- Functional requirements
- Raw material requirements
- Structural behaviour
- Reaction to fire



(Class E)

**CERTIFIED
UNI EN 858-1**



AUTOMATIC SHUT-OFF VALVE

ON REQUEST



TECHNICAL CHARACTERISTICS

Float valve in plastic calibrated for light liquids of density > 0.85 g/cm³

USE

When installed inside coalescence type oil separators it allows the outlet pipe to be closed automatically when the maximum oil containment level is reached.

Item

KITOTTG

OIL ALARM KIT

ON REQUEST

MATERIAL

Type-approved ATEX electric float switch in blow moulded polyethylene providing a perfect seal, visual and audible alarm signal, complete with wall-mounted unit.

FUNCTION

Installed inside an oil separator, the electric float switch has a unique characteristic that enables it to float on the water and not on the hydrocarbons. This allows a signal to be generated when a certain level of oil is reached inside the tank, indicating that cleaning operations need to be carried out.

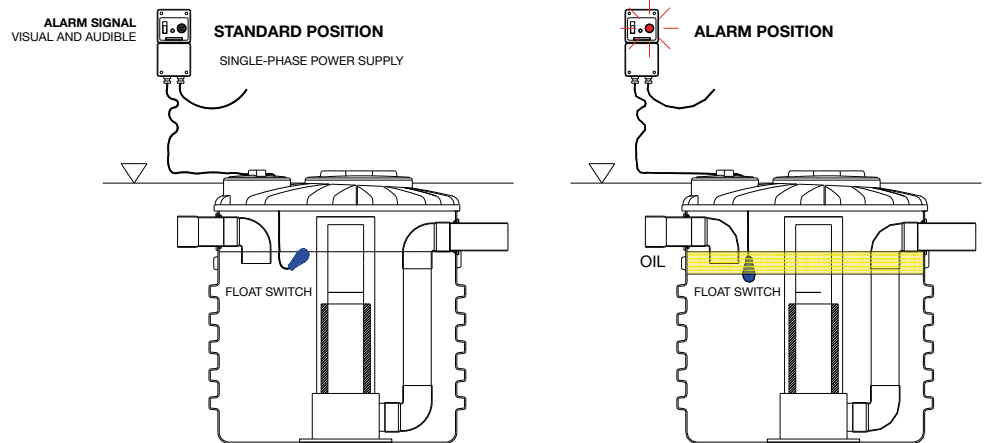

Item

KTAOIL

OIL SEPARATORS COALESCING FILTER TYPE

MODEL

CORRUGATED

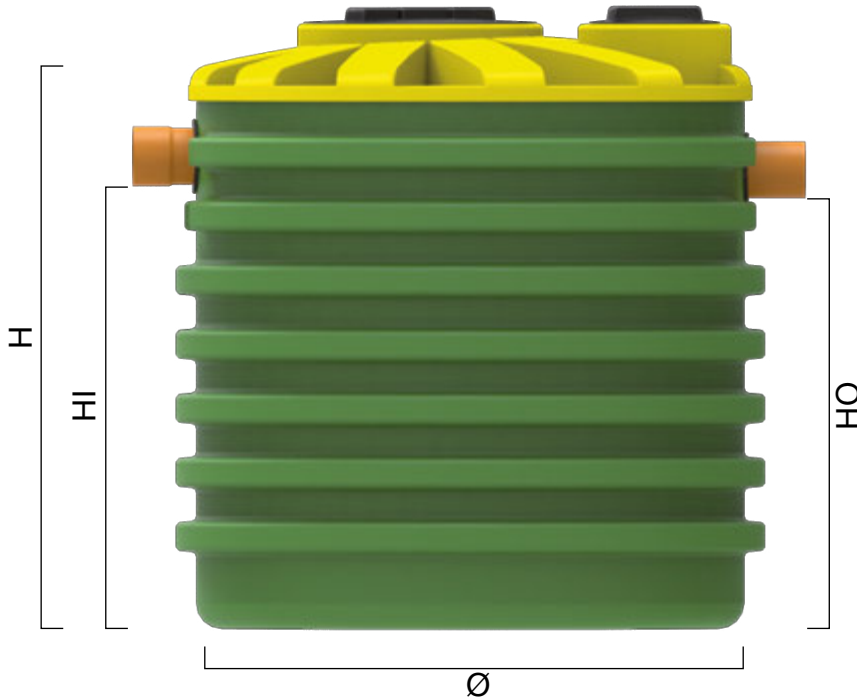

Item	Mod.	Ø mm	H mm	HI mm	HO mm	Ø I/O mm	Useful Vol. l	Oil Vol. l	NS l/s	Covered hardstanding m ²	Covered hardstanding Car spaces	Uncovered hardstanding m ²	Uncovered hardstanding Car spaces
NDOFC1000 1,5 l/s		1150	1220	880	860	125	850	27	1,5	675	54	270	22
NDOFC1500 2 l/s		1150	1720	1360	1340	125	1268	35	2	900	72	360	30
NDOFC1000 3 l/s		1150	1220	880	860	125	850	53	3	1350	108	540	43
NDOFC1500 4 l/s		1150	1720	1360	1340	125	1268	70	4	1800	144	720	58
NDOFC2100 6 l/s		1350	1975	1540	1520	125	1950	130	6	2700	200	1000	80
NDOFC2600 7,5 l/s		1710	1450	970	950	160	2061	152	7,5	3375	270	1350	110
NDOFC3200 10 l/s		1710	1725	1220	1200	160	2525	176	10	4500	360	1800	147
NDOFC3800 15 l/s		1710	1955	1430	1410	200	3175	225	15	6750	540	2700	220
NDOFC4600 20 l/s		1710	2225	1650	1630	200	3835	300	20	9000	720	3600	294
NDOFC5400 25 l/s		1950	2250	1600	1580	250	4347	375	25	11250	900	4500	367
NDOFC6400 30 l/s		1950	2530	1890	1870	250	5100	450	30	13500	1080	5400	440
NDOFC7000 35 l/s		2250	2367	1720	1700	315	6934	525	35	15750	1260	6300	515
NDOFC7000 40 l/s		2250	2367	1720	1700	315	6934	600	40	18000	1440	7200	588
NDOFC9000 50 l/s		2250	2625	1950	1930	315	7823	750	50	22500	1800	9000	734

Ø = diameter; H = height; HI = inlet pipe height; HO = outlet pipe height; ØI/O = inlet/outlet pipe diameter.

TECHNICAL SECTION – OIL SEPARATORS WITH COALESCING FILTER

TECHNICAL CHARACTERISTICS

Oils and greases are present in most industrial effluents. Their removal is necessary prior to discharge due to the negative aesthetic effects that they produce when discharged to a body of surface water and due to the damage caused to flora and fauna. Furthermore, their removal is also necessary as a pre-treatment prior to any other treatment phase, in that they create problems for the development of the biological treatment processes.

In the case of service stations, car washes, workshops and hardstandings, **oils and greases are essentially of a mineral type**. These are non-biodegradable even in the long term, so that the consequences of allowing these substances into the sewerage system or worse still into watercourses or the soil are even more negative, not only because of the risk of blockage, but because they cannot be degraded at all by the environment. To remove this type of pollutants, coalescing filter type oil separators are used when the final outlet is to a watercourse or soak-away system. These oil separators are defined as **class I** under UNI-EN 858-1.

Coalescing filter type oil separators allow **improved performance in removing light substances**. The system makes use of a polyurethane sponge support on which the oil and hydrocarbon particles collect until their dimensions are such that enable them to settle away from the effluent by gravity. This treatment is recommended in the presence of particularly severe limitations on the discharged concentrations of mineral oils and hydrocarbons. It is advisable to install a grit separator upstream of the oil separator in order to prevent solid particles from clogging the filter meshes.

USE AND MAINTENANCE

An excessive accumulation of floating material causes a reduction in the volume available for separation. This risk worsens in the presence of considerable quantities of sedimentable substances that settle at the bottom of the plant. To prevent the escape of solids and mineral oils that could compromise the quality of the discharged effluent, it is advisable to carry out frequent inspections and removal of the accumulated pollutants. These operations should be more frequent if the plant receives effluent from vehicle workshops, oil storage areas or service stations.

As far as maintenance of the coalescing filter oil separators is concerned, in addition to the normal emptying by specialist technicians, it is also advisable to remove the sponge support and wash it thoroughly upstream of the plant.

MANAGEMENT

WHAT TO DO	WHEN	HOW
Inspect the coalescing filter type oil separator	Every 1 / 2 months	Unscrew the covers on the inspection holes and check the level of sediment and the floating material
Clean the coalescing filter	Every 1 / 2 months	Extract the steel cage containing the filter and wash it with a jet of water at the head of the plant
Remove the floating material, the bottom sediment and clean the inlet and outlet pipes	Every 6 / 12 months	Contact a licensed waste disposal company

N.B. the frequency of cleaning operations depends on the amount of oil, grease and the frequency of rainfall.

PROHIBITIONS

- **do not use toxic and/or poisonous substances** (bleach, solvents, insecticides, disinfectant substances, aggressive detergents).

WARNINGS

- make sure that drains have a siphon;
- check that the pipes slope sufficiently (approximately 1% - 2%);
- connect the biogas vent pipe (**see installation method**);
- after pump-out, fill the tank again with **clean water**;
- in the event of a maintenance operation of any kind, always comply with the **safety regulations** regarding operations within closed waste water treatment areas, and with the general technical procedures applicable.

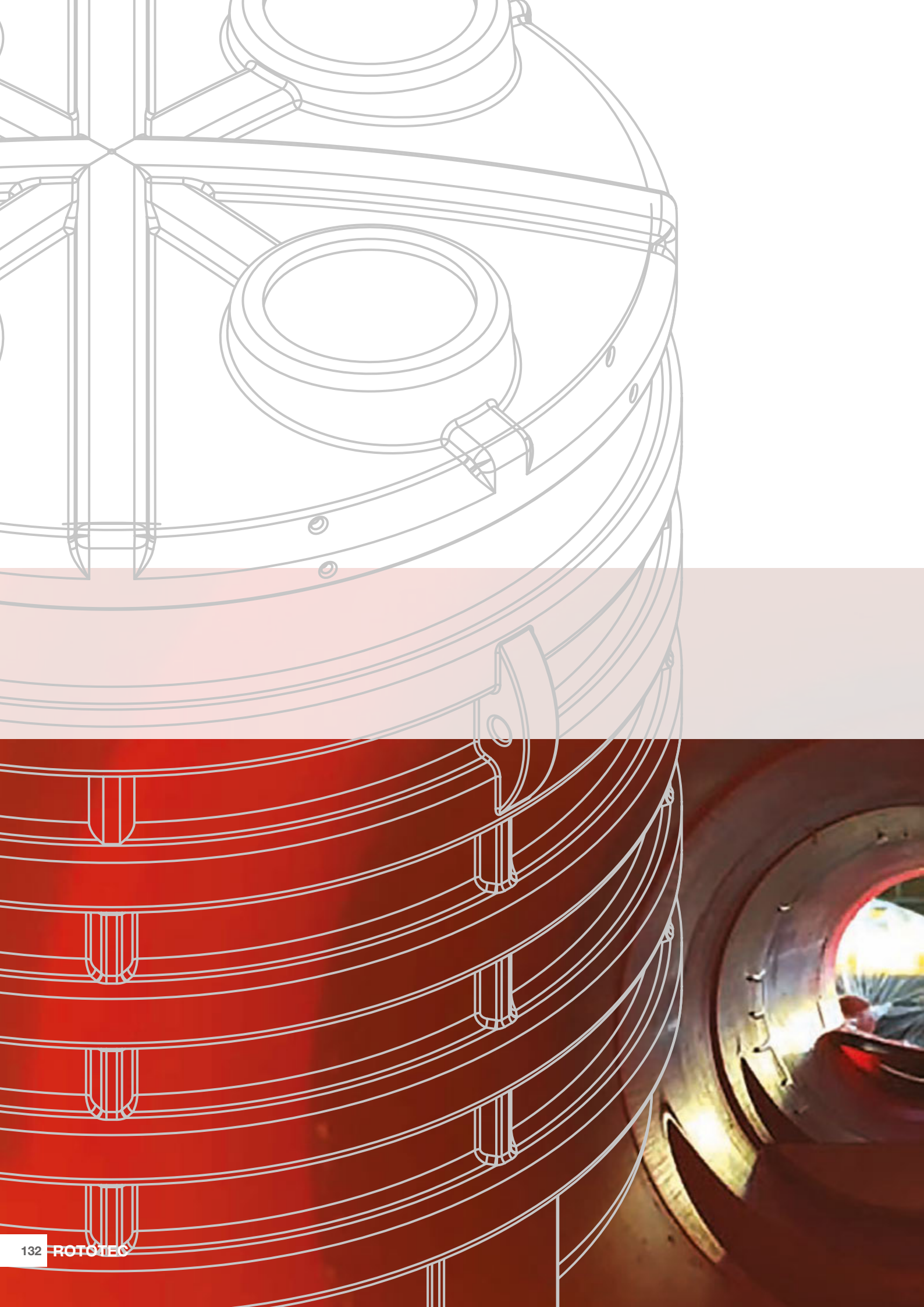

COALESCING OIL SEPARATOR WITH INTEGRATED BYPASS

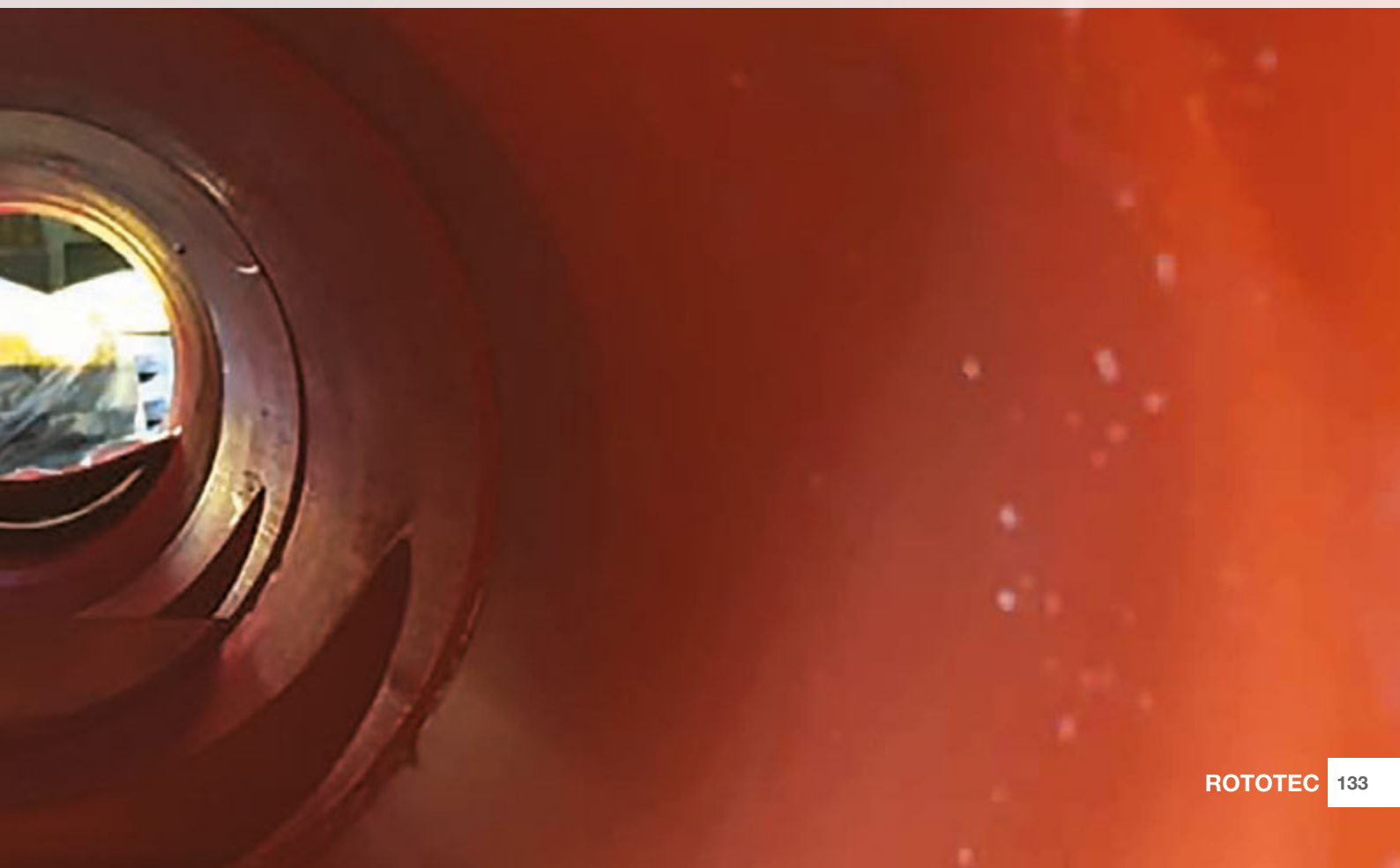

COALESCING OIL SEPARATOR ^{new}

WITH INTEGRATED BYPASS

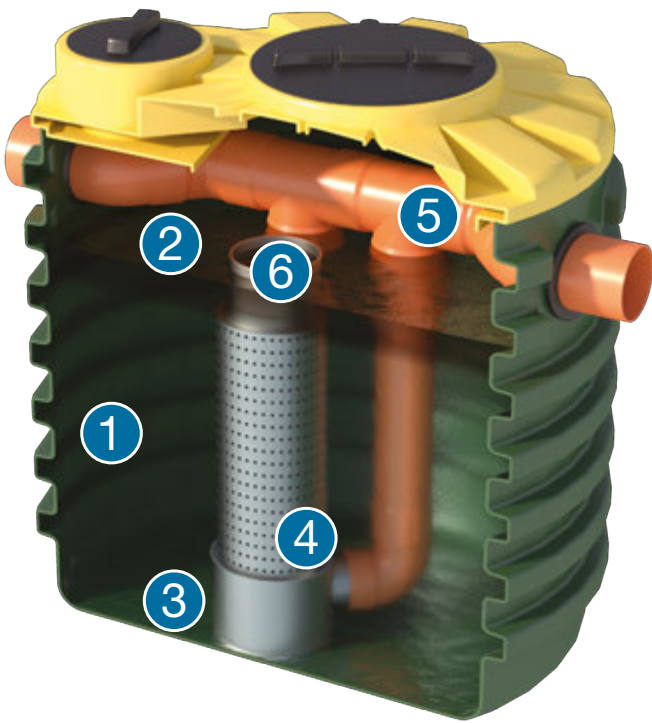

1 SEPARATION ZONE

stopping zone in which floating substances such as oil, grease and any foam are separated from the effluent and accumulate on the surface, while the heavy substances (stones, grit, pieces of rubber and metal,...) settle on the bottom of the tank.

2 OIL ACCUMULATION AREA

oils separated from the effluent accumulate on the surface.

3 HEAVY SEDIMENT ACCUMULATION AREA

the heavy materials separated from the effluent accumulate on the bottom of the tank

4 COALESCING FILTER

micro-bubble polyurethane filter inserted into a stainless steel grid, which can be extracted thanks to the presence of a base and guides, also made of stainless steel. The coalescing filter is able to join the fine particles of oil present in the effluent to form larger drops big enough to migrate towards the surface, thus separating from the effluent.

5 INTEGRATED BYPASS

activated automatically when the flow rate of the effluent at the inlet exceeds the design flow. The excess flow is sent directly to the outlet in order to prevent overloading the coalescing filter.

6 AUTOMATIC SHUT-OFF VALVE

float valve in plastic that allows the outlet pipe to be shut-off automatically when the maximum oil containment level has been reached.

INSTALLATION DIAGRAM

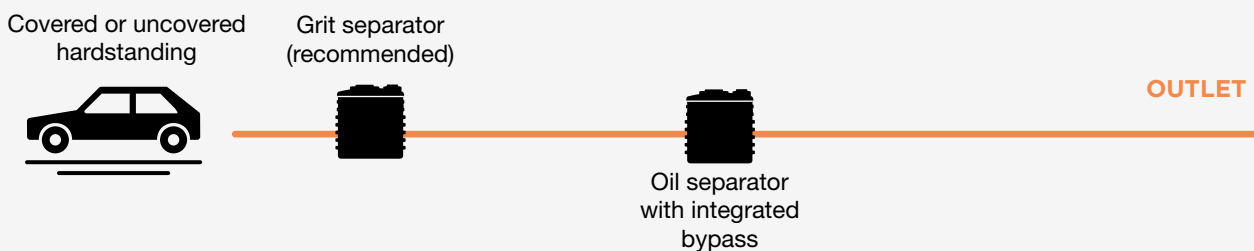

SPECIFICATIONS

TECHNICAL CHARACTERISTICS

Oil separators with coalescing filters guarantee improved performance in removing light substances. The system makes use of a polyurethane sponge support, enclosed in a stainless steel cage, on which the oil and hydrocarbon particles collect until their dimensions are such that enable them to settle away from the effluent by gravity. This treatment is recommended in the presence of particularly severe limitations on the concentrations of mineral oils and hydrocarbons at the discharge point. It is advisable to install a grit separator upstream of the oil separator in order to prevent solid particles from clogging the filter mesh.

The oil separator is equipped with an internal bypass manifold that is activated automatically when the flow rate of the effluent at the inlet exceeds the design flow. The excess flow is sent directly to the outlet in order to prevent overloading the coalescing filter. The actual flow treated is equal to 10% of the maximum inlet flow.

USE

Treatment of surface drainage water from covered and open-air hardstandings, car parks, car showrooms, garages

REFERENCE STANDARDS

UNI-EN 858-1

SEWAGE TREATMENT EFFICIENCY

The coalescing oil separator with integrated bypass (installed as shown in the diagram at page 134) ensures that the concentrations of the final effluent are:

≤5 mg/l
Total Hydrocarbons

≤80 mg/l
SS

These parameters are respected if the inlet wastewater have the following characteristics (typical concentrations of surface drainage water):

≤50 mg/l
Total Hydrocarbons

≤400 mg/l
SS

COALESCING OIL SEPARATOR WITH INTEGRATED BYPASS

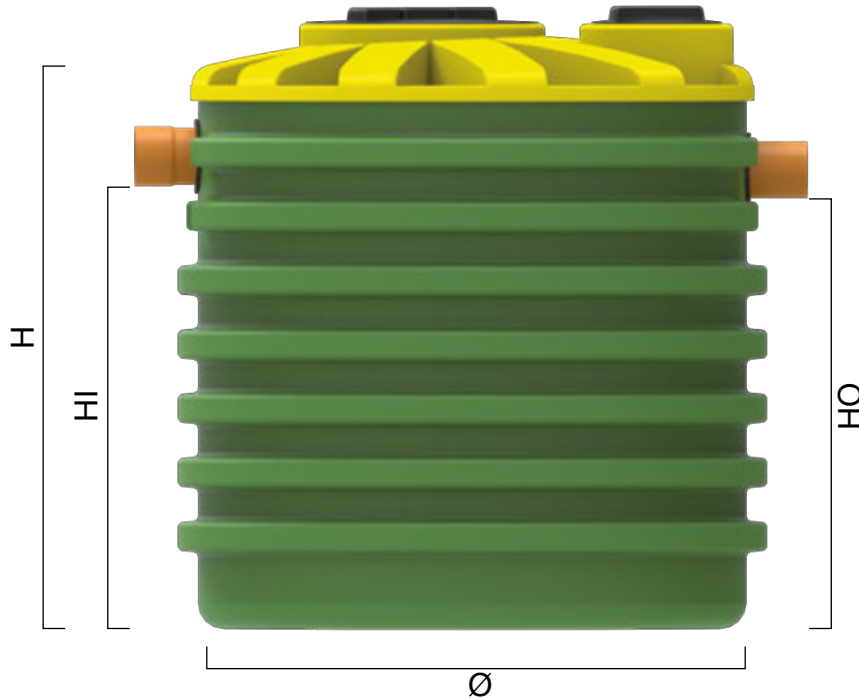

MODEL

CORRUGATED



Item	Mod.	Ø mm	H mm	IH mm	OH mm	Ø I/O mm	Useful Vol. l	NS x5	Max. capacity l/s	NS x10	Max. capacity l/s	Uncovered hardstanding m ²
NDOFC1000BPD160		1150	1220	830	820	160	900	3-15	15	-	-	2700
NDOFC1000BPD200		1150	1220	810	800	200	900	4-20	20	4-40	40	3600
NDOFC1500BPD200		1150	1720	1210	1200	200	1400	5-25	25	-	-	4500
NDOFC1500BPD250		1150	1720	1260	1250	250	1400	6-30	30	6-60	60	5400
NDOFC2100BPD250		1350	1975	1400	1390	250	2000	7-35	35	7-70	70	6300
NDOFC2600BPD250		1710	1450	860	850	250	2400	8-40	40	-	-	7200
NDOFC3200BPD315		1710	1725	1070	1060	315	3000	-	-	8-80	80	7200
NDOFC3800BPD315		1710	1955	1270	1260	315	3600	10-50	50	10-100	100	9000
NDOFC4600BPD315		1710	2225	1560	1550	315	4200	12-60	60	12-120	120	10800
NDOFC4600BPD400		1710	2225	1470	1460	400	4200	15-75	75	15-150	150	13500
NDOFC5400BPD400		1950	2250	1450	1440	400	5200	20-100	100	20-200	200	18000
NDOFC6400BPD400		1950	2530	1710	1700	400	5600	25-125	125	25-250	250	22500
NDOFC7000BPD400		2250	2367	1610	1600	400	6800	32-160	160	-	-	28800

Ø = diameter; H = height; IH = inlet pipe height; OH = outlet pipe height; ØI/O = inlet/outlet pipe diameter; NS = treated flow rate (l/s)-maximum inlet flow; MAX C = maximum capacity (l/s)..

TECHNICAL SECTION – COALESCING OIL SEPRATOR WITH BYPASS INTEGRATED

TECHNICAL CHARACTERISTICS

Oils and greases are present in most industrial effluents. Their removal is necessary prior to discharge due to the negative aesthetic effects that they produce when discharged to a body of surface water and due to the damage caused to flora and fauna. Furthermore, their removal is also necessary as a pre-treatment prior to any other treatment phase, in that they create problems for the development of the biological treatment processes.

In the case of service stations, car washes, workshops and hardstandings, **oils and greases are essentially of a mineral type**. These are non-biodegradable even in the long term, so that the consequences of allowing these substances into the sewerage system or worse still into watercourses or the soil are even more negative, not only because of the risk of blockage, but because they cannot be degraded at all by the environment. To remove this type of pollutants, coalescing filter type oil separators are used when the final outlet is to a watercourse or soak-away system.

Coalescing filter type oil separators allow **improved performance in removing light substances**. The system makes use of a polyurethane sponge support on which the oil and hydrocarbon particles collect until their dimensions are such that enable them to settle away from the effluent by gravity. This treatment is recommended in the presence of particularly severe limitations on the discharged concentrations of mineral oils and hydrocarbons. It is advisable to install a grit separator upstream of the oil separator in order to prevent solid particles from clogging the filter meshes.

USE AND MAINTENANCE

An excessive accumulation of floating material causes a reduction in the volume available for separation. This risk worsens in the presence of considerable quantities of sedimentable substances that settle at the bottom of the plant. To prevent the escape of solids and mineral oils that could compromise the quality of the discharged effluent, it is advisable to carry out frequent inspections and removal of the accumulated pollutants. These operations should be more frequent if the plant receives effluent from vehicle workshops, oil storage areas or service stations.

As far as maintenance of the coalescing filter oil separators is concerned, in addition to the normal emptying by specialist technicians, it is also advisable to remove the sponge support and wash it thoroughly upstream of the plant.

MANAGEMENT

WHAT TO DO	WHEN	HOW
Inspect the coalescing filter type oil separator	Every 1 / 2 months	Unscrew the covers on the inspection holes and check the level of sediment and the floating material
Clean the coalescing filter	Every 1 / 2 months	Extract the steel cage containing the filter and wash it with a jet of water at the head of the plant
Remove the floating material, the bottom sediment and clean the inlet and outlet pipes	Every 6 / 12 months	Contact a licensed waste disposal company

N.B. the frequency of cleaning operations depends on the amount of oil, grease and the frequency of rainfall.

PROHIBITIONS

• **do not use toxic and/or poisonous substances** (bleach, solvents, insecticides, disinfectant substances, aggressive detergents).

WARNINGS

- make sure that drains have a siphon;
- check that the pipes slope sufficiently (approximately 1% - 2%);
- connect the biogas vent pipe (**see installation method**);
- after pump-out, fill the tank again with **clean water**;
- in the event of a maintenance operation of any kind, always comply with the **safety regulations** regarding operations within closed waste water treatment areas, and with the general technical procedures applicable.



CONTINUOUS STORMWATER RUNOFF

TREATMENT PLANTS



STORMWATER RUNOFF CONTINUOUS TREATMENT PLANTS

WITH SEPARATE TANKS

(up to 9000 m² – 50 l/s)

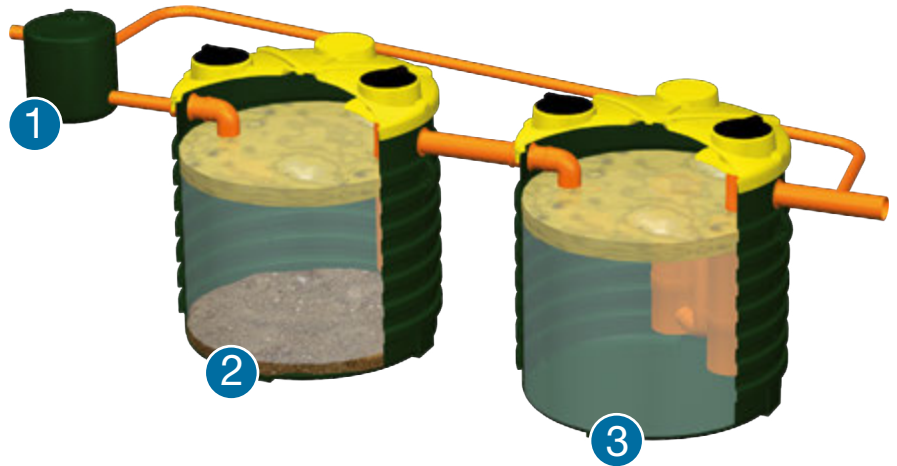

ONE-PIECE

from 11000 m² - 65 l/s

to 27000 m² - 150 l/s

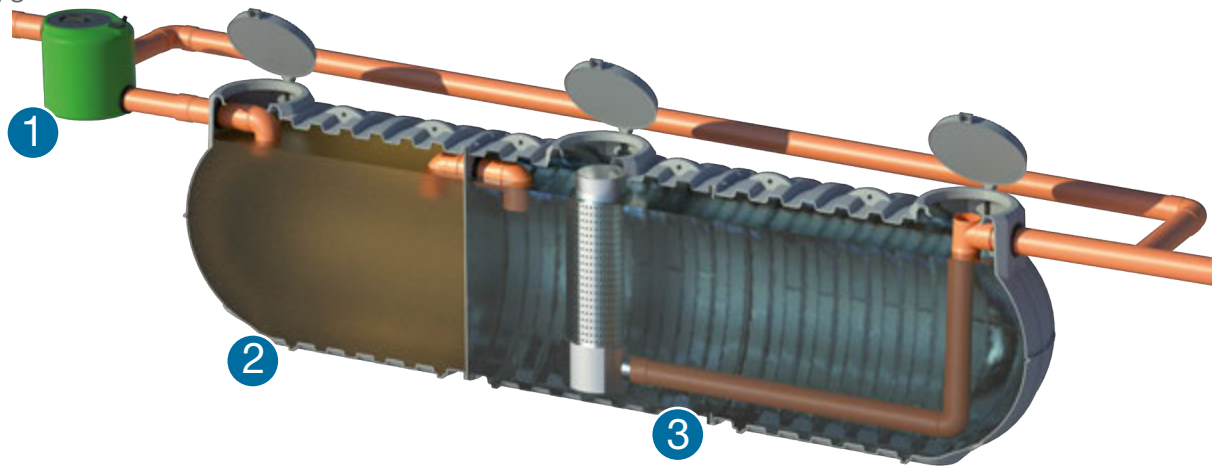

1 FLOW SPLITTING CHAMBER

carries the collected rainwater from the hardstanding to the grit separator and oil separator system. When the incoming flow exceeds the design specifications, part of the incoming water is carried directly to the end tank via the by-pass pipe

2 GRIT SEPARATOR SECTION

stopping tank in which the heavy substances (stones, grit, pieces of rubber and metal,...) settle and accumulate on the bottom of the tank. At the same time the larger light components (drops of oil, hydrocarbons and any foam) accumulate on the surface.

3 COALESCING FILTER TYPE OIL SEPARATION SECTION

thanks to the fine micro-bubble polyurethane coalescing filter inserted into a stainless steel grid, which can be extracted thanks to the presence of a base and guides, also made of stainless steel, the fine particles of oil and hydrocarbons join together to form drops that are large enough to migrate towards the surface, separating from the effluent.

SPECIFICATIONS

TECHNICAL CHARACTERISTICS

The plant allows the continuous treatment of stormwater runoff from impermeable surfaces up to 27000 m² used for transit or parking in industrial areas, residential zones and service stations subject to possible pollution from mineral oils, hydrocarbons, sand/grit and inert materials. The stormwater runoff treatment system makes use of the action of a grit and oil separator in continuous operation capable of treating flows of up to 150 l/s. Runoff from impermeable transit areas must be carried to the treatment system. The treatment tanks receive the flow appertaining to first 5 mm of rain falling over a 15 minute period. For higher flows, the by-pass is activated which sends the excess to the stormwater storage tanks. The treatment plant consists of a grit separator and a coalescing filter type oil separator.

The plant is effective for the following parameters:

- Sedimentable solids.
- Total hydrocarbons and other light liquids that have not been emulsified of specific weight up to 0.85 g/cm³.
- Unless otherwise specified, the peak flows in m³/h for each single model must be less than that indicated on the technical data sheet.
- Unless otherwise specified, the surface area (m²) of the hardstanding to treat for each single model must be less than or equal to the limits indicated on the technical data sheet.
- For that not specifically indicated, refer to the design data specified on the technical data sheet.

USE

Treatment of surface drainage water from open-air hardstandings, car parks, roads, service stations, warehouses,...

REFERENCE STANDARDS

Standard UNI EN 858-1 (oil separator), regional standards for treatment of rainwater.

PRODUCT CERTIFICATION

The Rototec oil separators with coalescing filter (excluding the modular range) are CE marked and have been designed, tested and certified under UNI EN 858-1 "Separator systems for light liquids (e.g. oil and petrol). Part 1: Principles of design, performance and product testing, marking and quality control".

The oil separators with coalescing filter have been verified and tested at Rototec and by a third party certifying body, and have been found to comply with the necessary requirements.

- Watertightness
- Structural stability
- Nominal capacity
- Functional requirements
- Raw material requirements
- Structural behaviour
- Reaction to fire



Class E

CERTIFIED
UNI EN 858-1

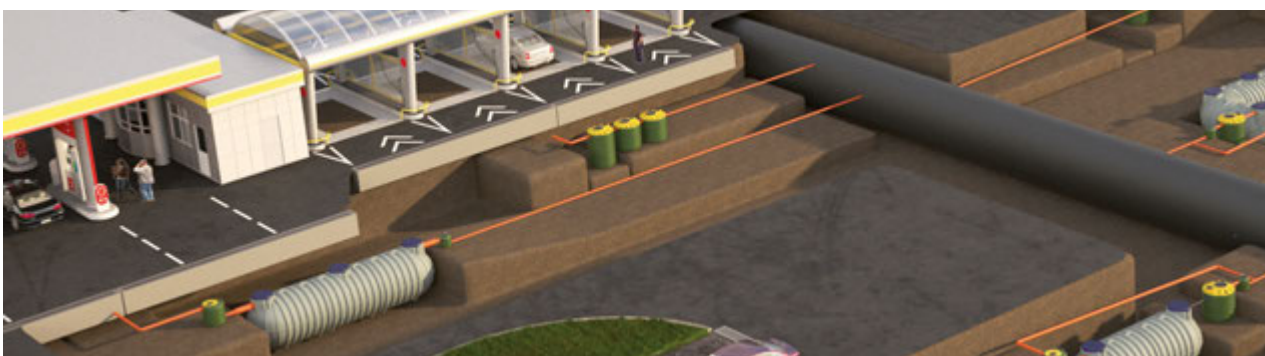
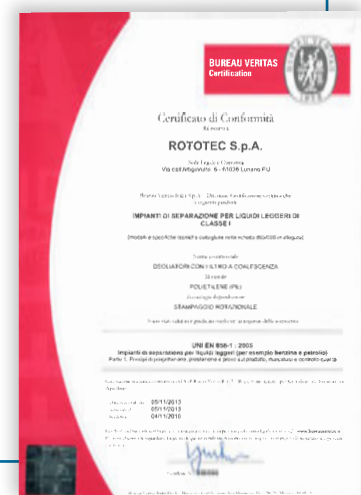

STORMWATER RUNOFF CONTINUOUS TREATMENT PLANTS

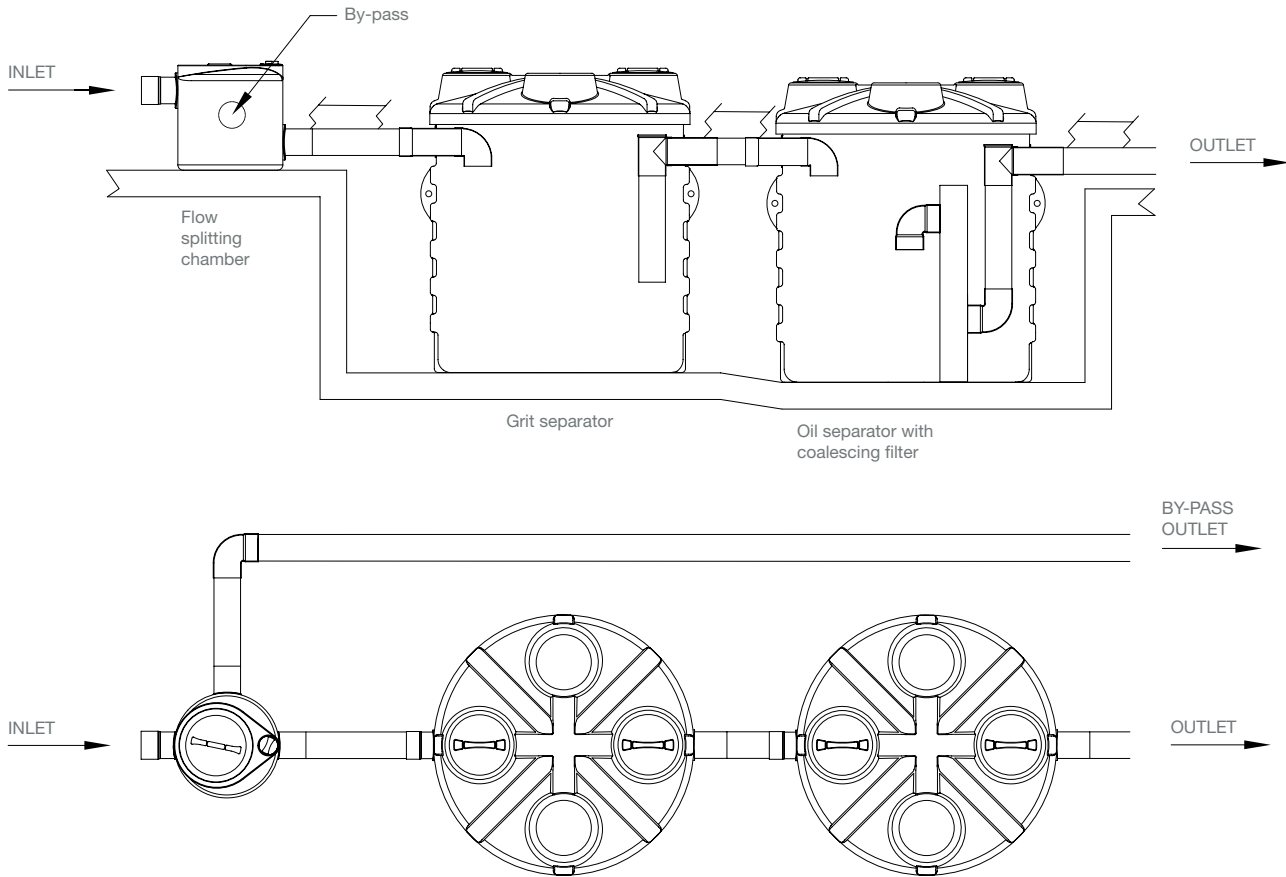

Item	Flow rate l/s	Uncovered hardstandings m ²	Useful vol. l	Oil vol. l	Grit vol. l	Flow splitting chamber			Grit separator			Oil separator		
						Item	ØxH mm	Ø pipes mm	Item	ØxH mm	Ø pipes mm	Item	ØxH mm	Ø pipes mm
IPC270	1,5	270	1700	27	150	PSC011212IPC	580x660	125	NDS1000	1150x1220	125	NDOFC1000 1,5LS	1150x1220	125
IPC360	2	360	2118	35	200	PSC011212IPC	580x660	125	NDS1000	1150x1220	125	NDOFC1500 2LS	1150x1720	125
IPC540	3	540	2118	53	300	PSC011212IPC	580x660	125	NDS1500	1150x1720	125	NDOFC1000 3LS	1150x1220	125
IPC720	4	720	2536	70	400	PSC011212IPC	580x660	125	NDS1500	1150x1720	125	NDOFC1500 4 LS	1150x1720	125
IPC1000	6	1000	3900	130	700	PSC011212IPP	580x660	125	NDS2100	1350x1975	125	NDOFC2100 6LS	1350x1975	125
IPC1350	7,5	1350	4122	152	860	PSC051616IPC	790x790	160	NDS2600	1710x1450	160	NDOFC2600 7,5LS	1710x1450	160
IPC1800	10	1800	5050	176	1000	PSC051616IPC	790x790	160	NDS3200	1710x1725	160	NDOFC3200 10LS	1710x1725	160
IPC2700	15	2700	6208	225	1500	PSC052020IPC	790x790	200	NDS3800	1710x1955	200	NDOFC3800 15LS	1710x1955	200
IPC3600	20	3600	7596	300	2000	PSC052020IPC	790x790	200	NDS4600	1710x2225	200	NDOFC4600 20LS	1710x2225	200
IPC4500	25	4500	8694	375	2500	PSC052525IPC	790x790	250	NDS5400	1950x2250	250	NDOFC5400 25 LS	1950x2250	250
IPC5400	30	5400	10200	450	3000	PSC052525IPC	790x790	250	NDS6400	1950x2530	250	NDOFC6400 30LS	1950x2530	250
IPC6300	35	6300	13868	525	3500	PSC103131IPC	1116x1140	315	NDS7000	2250x2367	315	NDOFC7000 35LS	2250x2367	315
IPC7200	40	7200	14757	600	4000	PSC103131IPC	1116x1140	315	NDS9000	2250x2625	315	NDOFC7000 40LS	2250x2367	315
IPC9000	50	9000	15357	750	5000	PSC103131IPC	1116x1140	315	NDS9000	2250x2625	315	NDOFC9000 50LS	2250x2625	315

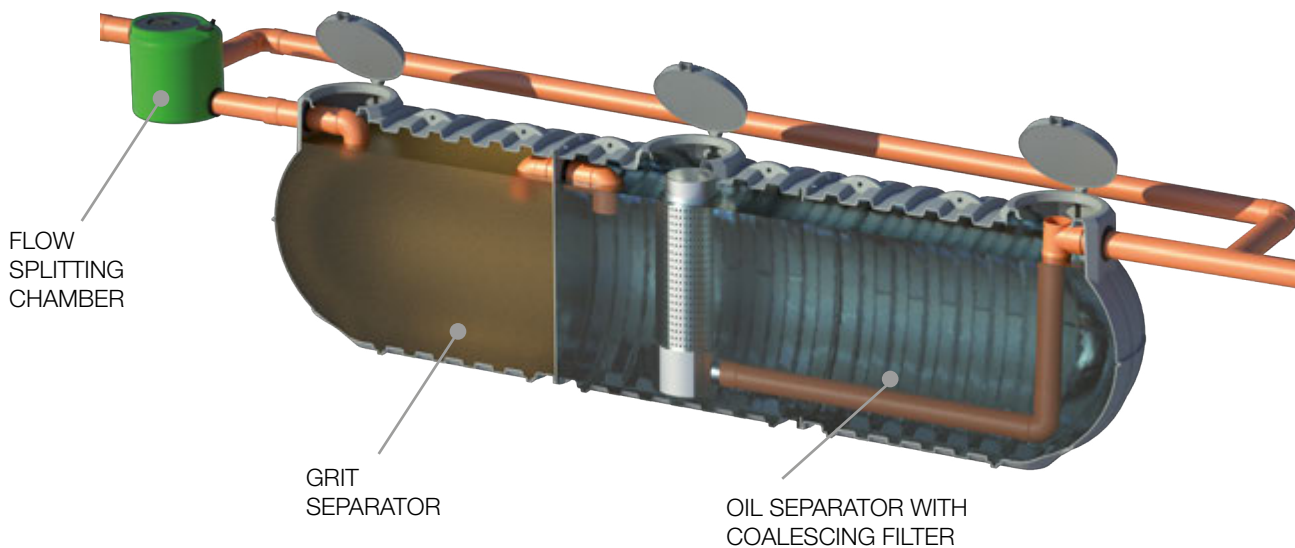

Item	Flow rate l/s	Uncovered hardstandings m ²	Flow splitting chamber			One-piece grit/oil separator				
			Item	Ø x H mm	ØI-ØO-ØBp mm	LxWxH mm	Useful vol. l	Oil vol. l	Grit vol. l	ØI/O mm
ITIPC9500	60	10800	PSC103131IPC	1160x1140	315-315-315	7270x2100x 2200	18500	800	5500	315-315
ITIPC10000	65	11500	PSC103131IPC	1160x1140	315-315-315	7880x2100x 2200	20500	1000	6700	315-315
ITIPC11500	80	14400	PSC103131IPC	1160x1140	315-315-315	9530x2100x 2200	25500	1200	7800	315-315
ITIPC12500	85	15300	PSC103131IPC	1160x1140	315-315-315	10140x2100x 2200	27000	1300	8600	315-315
ITIPC14000	90	16200	PSC103131IPC	1160x1140	315-315-315	11200x2100x 2200	29500	1400	9200	315-315
ITIPC15000	100	18000	PSC103131IPC	1160x1140	315-315-315	12400x2100x 2200	33500	1550	10000	315-315
ITIPC16500	110	19800	PSC103131IPC	1160x1140	315-315-315	13460x2100x 2200	36000	1700	11000	315-315
ITIPC18000*	120	22000	PSC103131IPC	1160x1140	315-315-315	14660x2100x 2200	40000	1850	13000	315-315
ITIPC19000*	130	23400	PSC103131IPC	1160x1140	315-315-315	15720x2100x200	42500	2000	14000	315-315
ITIPC20500*	140	25200	PSC104031IPC	1160x1140	400-315-400	16310x2100x2200	44500	2150	14700	315-315
ITIPC22000*	150	27000	PSC104031IPC	1160x1140	400-315-400	16920x2100x2200	46500	2300	15500	315-315

* ON SITE WELDING

FLOW SPLITTING CHAMBERS

MATERIAL

One-piece polyethylene container (LLDPE) with PVC inlet and bypass pipes or PE sockets (dimension > 315) and PVC outlet pipe.

FUNCTION

the flow splitter chamber is installed upstream of a stormwater runoff treatment plant. Its function is to deliver rainwater to the treatment plant and to convey the water in excess of the design flow of the plant to the continuous water treatment plant.

Item	Ø mm	H mm	IH mm	HBp mm	OH mm	Ø I mm	Ø Bp mm	Ø O mm	Cover
PSC011212IPC	580	660	390	380	290	125	125	125	CC300
PSC051616IPC	790	790	490	340	220	160	160	160	CC400
PSC052016IPC	790	790	450	340	220	200	200	160	CC400
PSC052020IPC	790	790	410	360	210	200	200	200	CC400
PSC052516IPC	790	790	390	340	220	250	250	160	CC400
PSC052520IPC	790	790	390	360	210	250	250	200	CC400
PSC052525IPC	790	790	350	300	110	250	250	250	CC400
PSC103131IPC	1160	1140	620	600	400	315	315	315	CC400
PSC104031IPC	1160	1140	570	480	240	400	400	315	CC400

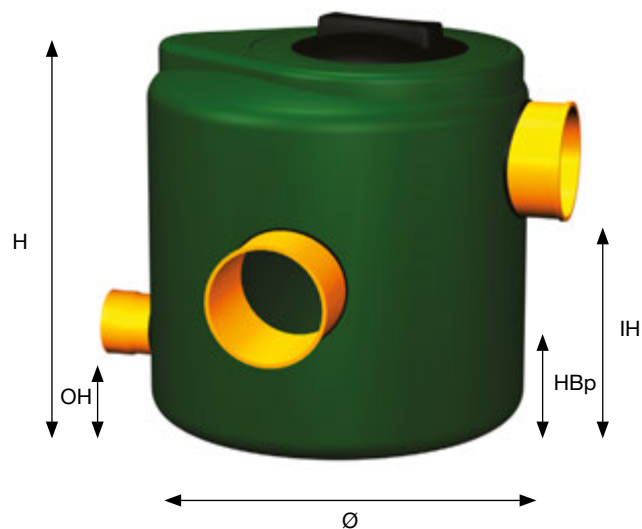

TECHNICAL SECTION – STORMWATER RUNOFF CONTINUOUS TREATMENT PLANTS

TECHNICAL CHARACTERISTICS

The plant allows the continuous treatment of stormwater runoff from **impermeable surfaces up to 27000 m²** used for transit or parking in industrial areas, residential zones and service stations subject to possible pollution from mineral oils, hydrocarbons, sand/grit and inert materials. The stormwater runoff treatment system makes use of the action of a grit and oil separator in continuous operation capable of treating **flows of up to 150 l/s**.

Runoff from impermeable transit areas must be carried to the treatment system. For flow rates higher than the design data, the by-pass is activated, sending the excess flow to the rainwater system.

The coalescing filter type oil separators are certified under standard UNI EN 858-1 and are CE-marked.

The plant is effective for the following parameters:

- Sedimentable solids.
- Total hydrocarbons and other light liquids that have not been emulsified of specific weight up to 0.85 g/cm³.

USE AND MAINTENANCE

The pollutants separated from the stormwater runoff inside the plant are mainly non-biodegradable (grit, lime, stone, hydrocarbons, oils, etc.). These tend to build up inside the various tanks. Over time, this build-up becomes excessive and tends to **have a negative effect on the efficiency** of the treatment plant (blocked pipes, release of the pollutants themselves, etc.).

It is therefore necessary to carry out **periodic inspection** of the tanks and, if necessary, to pump them out and clean them, contacting **licensed waste disposal companies**.

The inspections must be more frequent during the first months the system is in operation, in order to identify approximately how often pump-out will be necessary.

MANAGEMENT

WHAT TO DO	WHEN	HOW
Inspect the grit separator	Every 1 / 2 months	Unscrew the covers on the inspection holes and check the level of sediment and the floating material
Inspect the coalescing filter type oil separator	Every 1 / 2 months	Unscrew the covers on the inspection holes and check the level of sediment and the floating material
Clean the coalescing filter	Every 1 / 2 months	Extract the steel cage containing the filter and wash it with a jet of water at the head of the plant
Remove the floating material, the bottom sediment and clean the inlet and outlet pipes	Every 6 / 12 months	Contact a licensed waste disposal company who will empty all the elements in the plant

N.B. the frequency of cleaning operations depends on the amount of oil, grease and the frequency of rainfall.

WARNINGS

- make sure that drains have a siphon;
- check that the pipes slope sufficiently (approximately 1% - 2%);
- connect the biogas vent pipe (see installation method);
- after pump-out, fill the tank again with clean water;
- inspect the tanks periodically both during and after rain, so as to check that the various devices and elements are working properly;
- in the event of a maintenance operation of any kind, always comply with the safety regulations regarding operations within closed waste water treatment areas, and with the general technical procedures applicable.



BALANCING TANKS



GRAVITY TYPE BALANCING TANKS

new

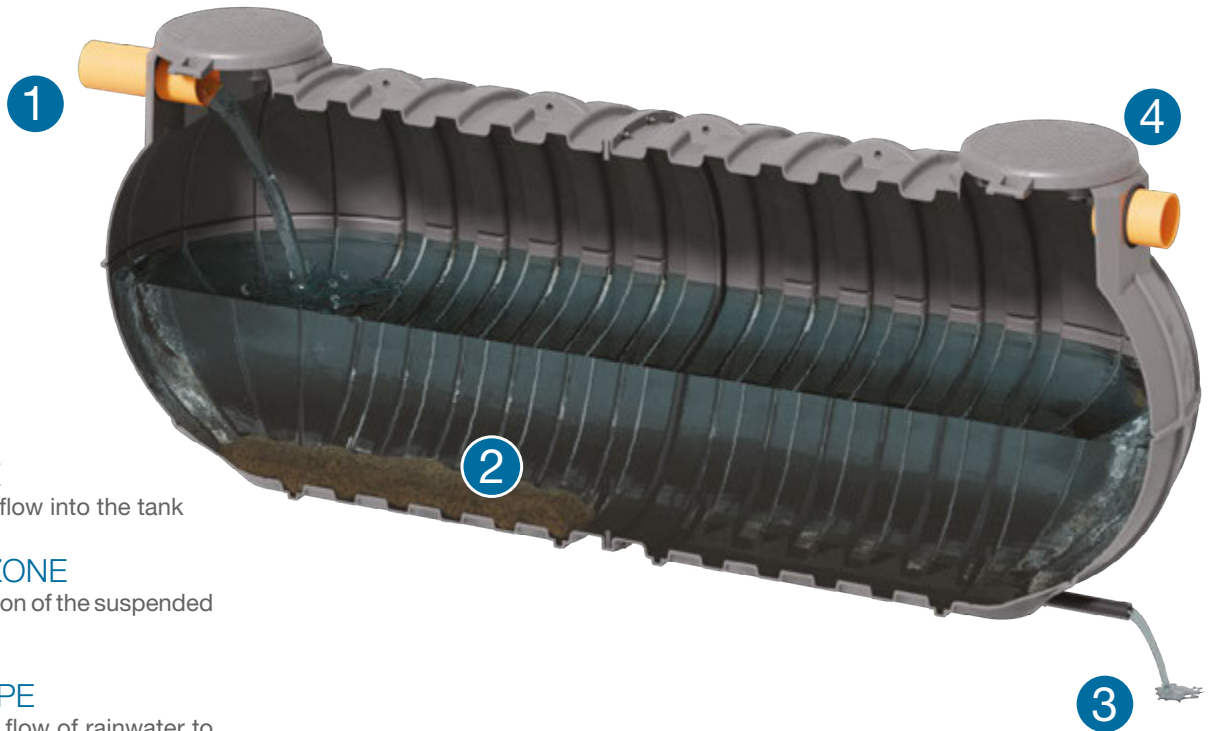

- 1 INLET PIPE
to transfer the flow into the tank
- 2 STILLING ZONE
for sedimentation of the suspended solids
- 3 OUTLET PIPE
to regulate the flow of rainwater to discharge to the final receptor
- 4 SAFETY OVERFLOW

INSTALLATION DIAGRAM



SPECIFICATIONS

TECHNICAL CHARACTERISTICS

The balancing tank is a storage unit that has the purpose of regulating the flow of rainwater discharged into the final receptor (public sewer, ditch, watercourse,...). This is in order to discharge a flow that does not exceed the limit specified by the regional and local governments and/or the water authority.

The rainwater is fed to the gravity balancing tank through an inlet pipe and is discharged to the receptor through an outlet pipe located at the bottom of the tank. The diameter of the outlet pipe is such that the maximum discharge flow is never more than the permitted discharge to the receptor. In this manner, in the case of heavy rainfall, the water exceeding the permitted discharge rate is stored temporarily in the tank and released over a longer period of time.

Balancing tanks are required in all those areas where a high soil impermeability overloads stormwater sewerage systems, ditches or natural watercourses, thus creating rainwater disposal problems, above all during severe meteorological events.

USE

Temporary storage of rainwater collected from an impermeable surface (roads, car parks, roofs, coverings in general, warehouses, pavements, etc.) during a meteorological event.

REFERENCE STANDARDS

Local regulations.



GRAVITY TYPE BALANCING TANKS

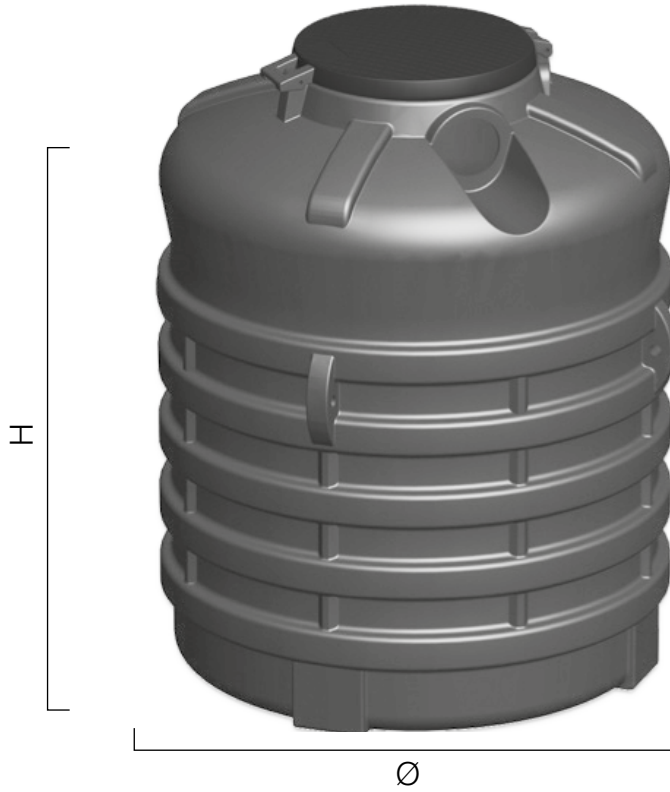

MODEL

CISTERNA



PANETTONE



MINITANK



INFINITANK

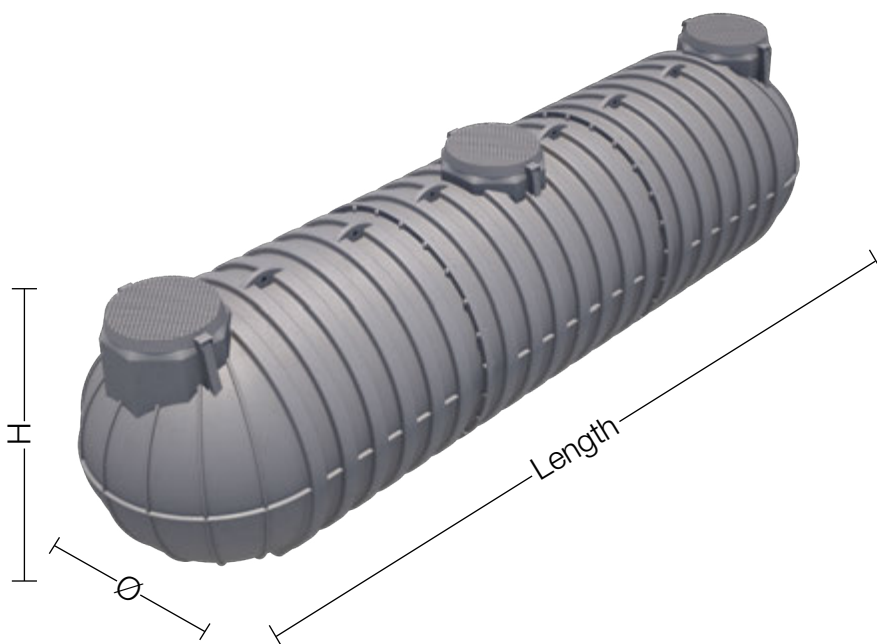

STORAGE TANKS

Item	Model	Capacity l	Length mm	Width mm	Ø mm	H mm	Covers	Extensions (optional)	Maximum* inlet Ø mm
CI3000	cisterna	3100	2090	1500	-	1720	TAP800	PP77	160
NPI4000	panettone	4050	-	-	1710	2150	TAP800	PP77	200
CI5700	cisterna	5700	2420	1920	-	2100	TAP800	PP77	250
NPI8000	panettone	7800	-	-	2270	2750	TAP800	PP77	200
CI10700	cisterna	10700	2780	2430	-	2580	TAP800	PP77	315
MT12000	minitank	12000	7180	1550	-	1710	TAP800	PP77	250
IT15000	infini-tank	15000	5620	2100	-	2200	TAP800	PP77	400
MT18000	minitank	18000	10510	1550	-	1710	TAP800	PP77	250
IT22000	infini-tank	22000	7880	2100	-	2200	TAP800	PP77	400
IT30000	infini-tank	30000	10140	2100	-	2200	TAP800	PP77	400
IT36000	infini-tank	36000	12400	2100	-	2200	TAP800	PP77	400

*maximum diameter of inlet pipe that can be installed on the tank

INLET AND OVERFLOW PIPES

Manufactured in PVC with NBR gasket, or with coupling for corrugated pipe in welded PE

Item	Type	Ø mm	Inlet flow rate l/s*
6TRPVC110	PVC	110	7.0
6TRPVC125	PVC	125	9.8
6TRPVC160	PVC	160	18.8
6TRPVC200	PVC	200	33.8
6TRPVC250	PVC	250	60.2
6TRPVC315	PVC	315	109.5
6MANPE250	PE	250	60.2
6MANPE315	PE	315	109.5
6MANPE400	PE	400	203.11



*inlet flow rate considering filling to 70% capacity and an inlet pipe gradient of 1%

DISCHARGE PIPE

Created using PE pipes welded to the tank

Item	Ø mm	Inlet flow rate l/s*
6TRPE040S	40	4.2
6TRPE050S	50	6.6
6TRPE063S	63	10.3
6TRPE075S	75	17.5
6TRPE090S	90	26.4
6TRPE125S	125	41.3



*discharge flow considering a depth of water of 1.5 m inside the tank

BALANCING TANKS WITH ELECTRIC PUMP

new

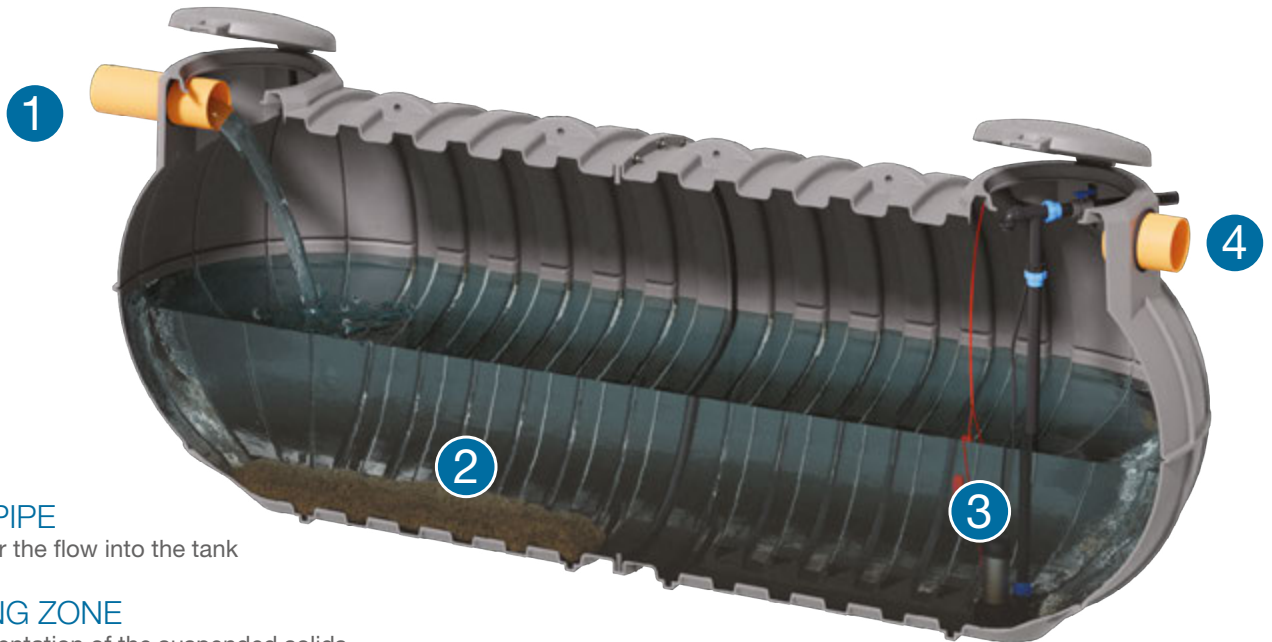

- 1 INLET PIPE
to transfer the flow into the tank
- 2 STILLING ZONE
for sedimentation of the suspended solids
- 3 SUBMERSIBLE ELECTRIC PUMP
to regulate the flow of rainwater to discharge to the final receptor
- 4 SAFETY OVERFLOW

INSTALLATION DIAGRAM



SPECIFICATIONS

TECHNICAL CHARACTERISTICS

The balancing tank is a temporary storage unit that has the purpose of regulating the flow of rainwater discharged into the final receptor (public sewer, ditch, watercourse,...). This is in order to discharge a flow that does not exceed the limit specified by the regional and local governments and/or the water authority.

The rainwater is fed to the balancing tank with pump through an inlet pipe and is discharged to the receptor by a submersible pump. The discharge flow rate of the pump can be controlled using a manual valve located on the pump delivery pipe. In this manner, in the case of heavy rainfall, the water exceeding the pump discharge rate is stored temporarily in the tank and released over a longer period of time.

Balancing tanks are required in all those areas where a high soil impermeability overloads stormwater sewerage systems, ditches or natural watercourses, thus creating rainwater disposal problems, above all during severe meteorological events.

USE

Temporary storage of rainwater collected from an impermeable surface (roads, car parks, roofs, coverings in general, warehouses, pavements, etc.) during a meteorological event.

REFERENCE STANDARDS

Local regulations.



BALANCING TANKS WITH ELECTRIC PUMP

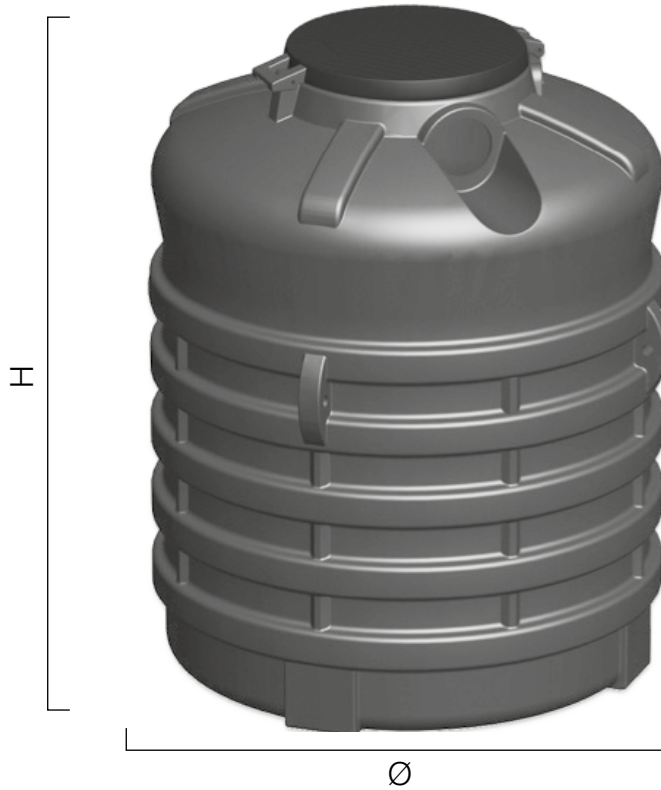

MODEL

CISTERNA



PANETTONE



MINITANK



INFINITANK

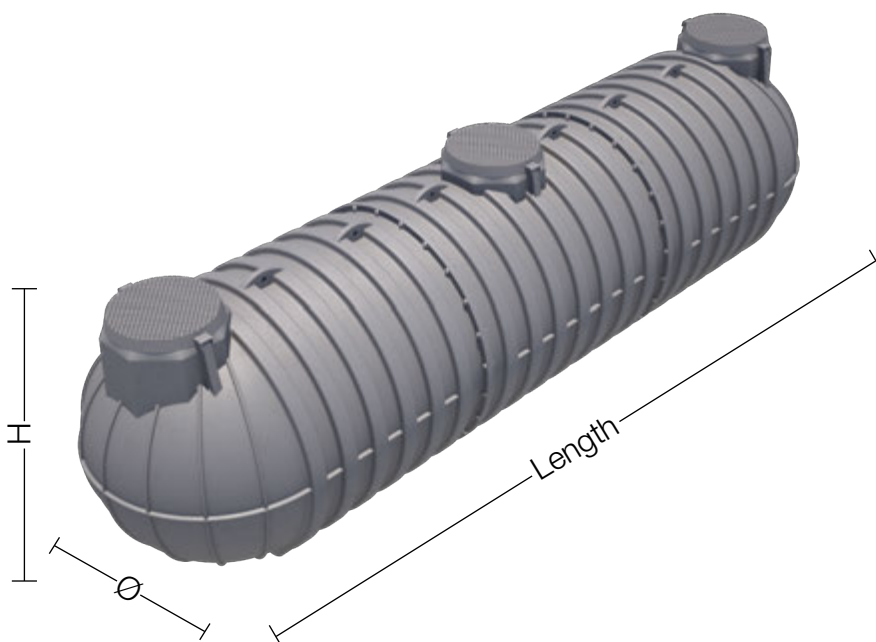

STORAGE TANKS

Item	Model	Capacity l	Length mm	Width mm	Ø mm	H mm	Covers	Extensions (optional)	Maximum* inlet Ø mm
CI3000	cisterna	3100	2090	1500	-	1720	TAP800	PP77	160
NPI4000	panettone	4050	-	-	1710	2150	TAP800	PP77	200
CI5700	cisterna	5700	2420	1920	-	2100	TAP800	PP77	250
NPI8000	panettone	7800	-	-	2270	2750	TAP800	PP77	200
CI10700	cisterna	10700	2780	2430	-	2580	TAP800	PP77	315
MT12000	minitank	12000	7180	1550	-	1710	TAP800	PP77	250
IT15000	infini-tank	15000	5620	2100	-	2200	TAP800	PP77	400
MT18000	minitank	18000	10510	1550	-	1710	TAP800	PP77	250
IT22000	infini-tank	22000	7880	2100	-	2200	TAP800	PP77	400
IT30000	infini-tank	30000	10140	2100	-	2200	TAP800	PP77	400
IT36000	infini-tank	36000	12400	2100	-	2200	TAP800	PP77	400

*maximum diameter of inlet pipe that can be installed on the tank

INLET AND OVERFLOW PIPES

Manufactured in PVC with NBR gasket, or with coupling for corrugated pipe in welded PE

Item	Type	Ø mm	Inlet flow rate l/s*
6TRPVC110	PVC	110	7.0
6TRPVC125	PVC	125	9.8
6TRPVC160	PVC	160	18.8
6TRPVC200	PVC	200	33.8
6TRPVC250	PVC	250	60.2
6TRPVC315	PVC	315	109.5
6MANPE250	PE	250	60.2
6MANPE315	PE	315	109.5
6MANPE400	PE	400	203.11



*inlet flow rate considering filling to 70% capacity and an inlet pipe gradient of 1%

DELIVERY PUMP KIT

Electric delivery pump installed inside the balancing tank with start and stop float switch, delivery pipe in PE, clapet type check valve, manual valve for regulating the discharge flow.

Item	Power kW	Pump model	Flow rate l/min	Head m	Pipe Ø mm
7KSM155IPP	0.25	SM155L	0-200	6.5 - 0	50
7KSM265IPP	0.55	SM265L	0-300	8.5 - 1	50

*The price includes all fittings and installation of the kit in the tank



A QCSOLP1 control panel is available on request

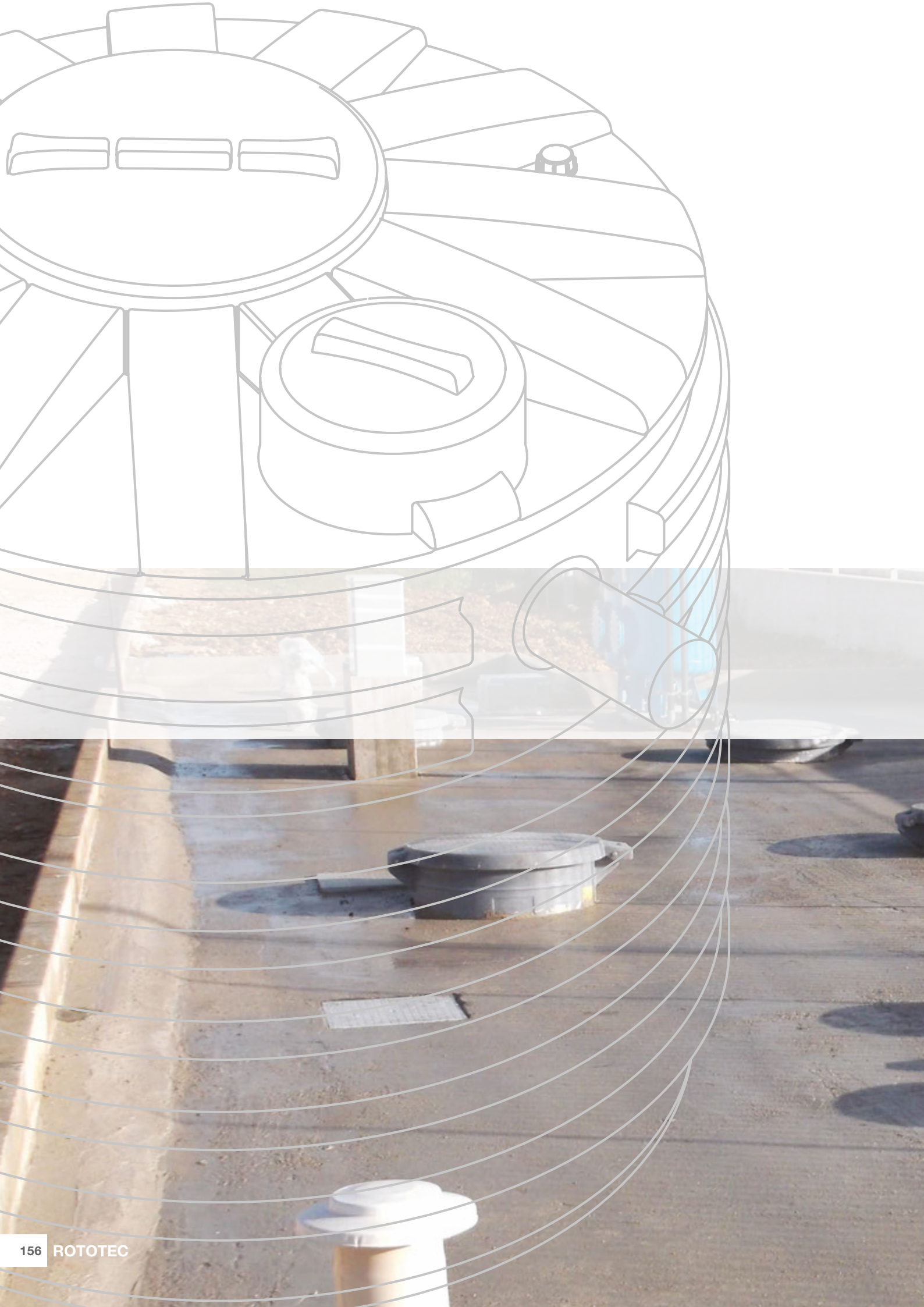

TREATMENT PLANTS FOR CAR WASHES



PLANTS FOR CAR WASHES



SPECIFICATIONS

The growing interest for **environmental protection and safety** is focussing more and more not only on treatment for domestic sewage or the like but also, particularly in recent years, on treatment systems for runoff from potentially polluted impermeable surfaces.

This includes water from car washes, which is characterised by the presence of **various types of pollutants** such as: suspended solids (sand and mud, gravel, grit, vegetable residues,...), detergents, oils and hydrocarbons. For this reason, the purification treatment of these effluents requires a series of phases that treat the pollutants in succession. Choice of the different types of treatment varies according to the final discharge. The inlet concentrations are : SS ≤ 400 mg/l ; Total Hydrocarbons ≤ 50 mg/l ; Total Surfactants ≤ 15 mg/l.

The first phase consists of a **grit separator** in which all the compounds of specific weight different to that of water are separated by gravity: the heavier materials (sand, mud, gravel,...) settle to the bottom of the tank while the lighter materials (oil, grease, foam,...) accumulate at the surface. The outlet pipe draws from halfway down the tank to prevent the separated material from being drawn-off.

The second phase is the **oil separation**. The residual oils and hydrocarbons are trapped by the coalescing filters, thus separating them from the effluent.

In the third phase, the effluent is subjected to intensive biological treatment, in which the particular strains of bacteria digest the dissolved organic substances (BOD5 and COD) and the detergents (Phosphorous). According to the final discharge concentrations requested by the local regulations, the third treatment phase consists of: an aerated trickle filter (DEPAUTO PF); an anaerobic trickle filter and an aerated trickle filter with sludge recirculation (DEPAUTO); an aerated trickle filter and a final quartzite and activated charcoal filter system (DEPAUTO T4) that permit to reuse the treated water for the pre-wash phase of the washing cycle. The blowers of the aerated trickle filters must remain in operation 24 hours a day.

USE

Treatment of water from manual and automatic car wash areas.

REFERENCE STANDARDS

Standard UNI EN 858-1 (oil separator), local standards for treatment of rainwater and surface runoff.

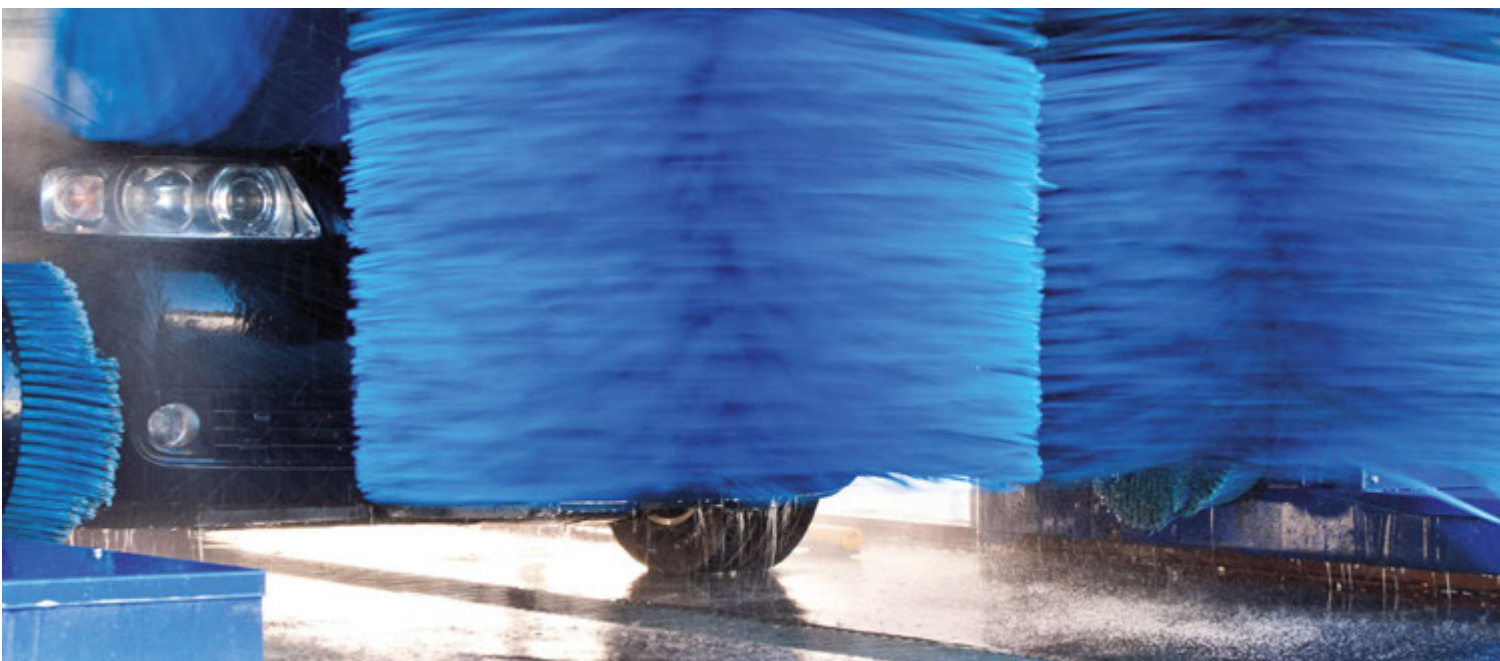

PLANTS FOR CAR WASHES

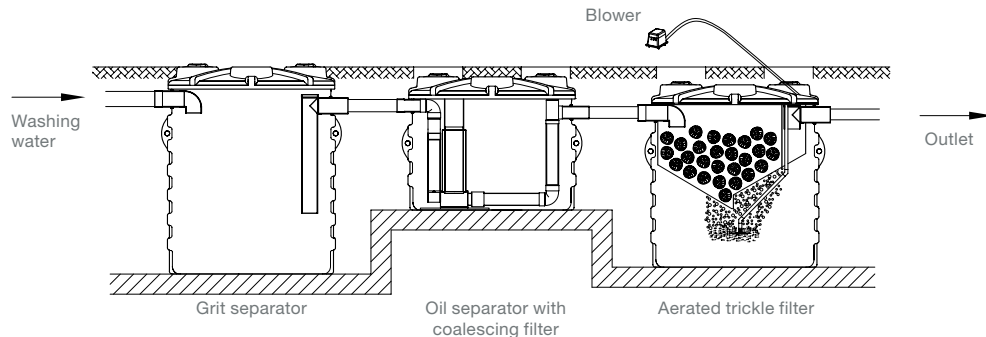

Item	Sizing			Plant composition										
	Cars/day n°	Hydraulic load l/day	Max Q l/h	Grit separator				Oil separator			Aerated trickle filter			
				Model	Ø mm	H mm	V tot l	Model	Ø mm	H mm	Model	Ø mm	H mm	V tot l
DEPAUTO10PF	0-10	2000	400	NDD1500	1150	1720	1193	NDOFC1000 1,5 l/s	1150	1220	NANA1000	1150	1220	850
DEPAUTO20PF	11-20	4000	400	NDD2600	1710	1450	1971	NDOFC1000 1,5 l/s	1150	1220	NANA1500	1150	1720	1268
DEPAUTO30PF	21-30	6000	600	NDD2600	1710	1450	1971	NDOFC1500 2 l/s	1150	1720	NANA2100	1350	1975	1950
DEPAUTO40PF	31-40	8000	800	NDD3200	1710	1725	2435	NDOFC1000 3 l/s	1150	1220	NANA2100	1350	1975	1950
DEPAUTO50PF	41-50	10000	1200	NDD3800	1710	1955	3026	NDOFC1500 4 l/s	1150	1720	NANA3200	1710	1725	2525
DEPAUTO60PF	51-60	12000	1500	NDD4600	1710	2225	3510	NDOFC2600 7,5 l/s	1710	1450	NANA3200	1710	1725	2525
DEPAUTO80PF	61-80	16000	2200	NDD6400	1950	2530	4862	NDOFC2600 7,5 l/s	1710	1450	NANA3800	1710	1955	3104
DEPAUTO100PF	81-100	20000	3000	NDD7000	2250	2367	6711	NDOFC2600 7,5 l/s	1710	1450	NANA4600	1710	2225	3835

TREATMENT EFFICIENCY

The treatment plant for car washes made up of a grit separator, an oil separator with coalescing filter and an aerated trickle filter (installed as shown above) ensures that the concentrations of the final effluent are:

≤200 mg/l
SS

≤10 mg/l
Total Hydrocarbons

≤4 mg/l
Total surfactants

PLANTS FOR CAR WASHES

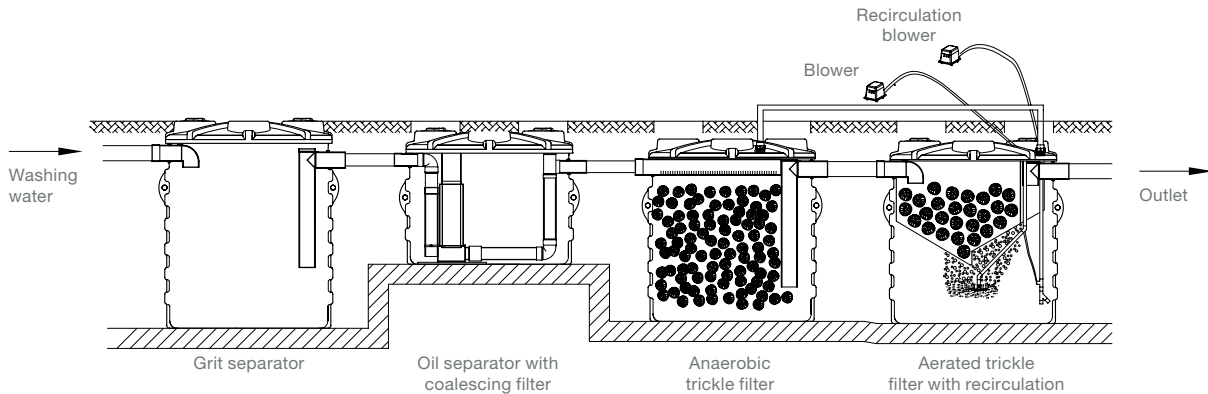

Item	Sizing			Plant composition															
	Cars/day n°	Hydraulic load l/day	Max Q l/h	Grit separator				Oil separator			Anaerobic trickle filter				Aerated trickle filter with sludge recirculation				
				Model	Ø mm	H mm	V tot l	Model	Ø mm	H mm	Model	Ø mm	H mm	V tot l	Model	Ø mm	H mm	V tot l	
DEPAUTO10	0-10	2000	400	NDD1500	1150	1720	1193	NDOFC1000	1,5 l/s	1150	1220	NAN1000R	1150	1220	850	NANAR1000	1150	1220	850
DEPAUTO20	11-20	4000	400	NDD2600	1710	1450	1971	NDOFC1000	1,5 l/s	1150	1220	NAN1500R	1150	1720	1268	NANAR1500	1150	1720	1268
DEPAUTO30	21-30	6000	600	NDD2600	1710	1450	1971	NDOFC1500	2 l/s	1150	1720	NAN1500R	1150	1720	1268	NANAR2600	1710	1450	1971
DEPAUTO40	31-40	8000	800	NDD3200	1710	1725	2435	NDOFC1000	3 l/s	1150	1220	NAN2600R	1710	1450	1971	NANAR2600	1710	1450	1971
DEPAUTO50	41-50	10000	1200	NDD3800	1710	1955	3026	NDOFC1500	4 l/s	1150	1720	NAN3200R	1710	1725	2435	NANAR3200	1710	1725	2435
DEPAUTO60	51-60	12000	1500	NDD4600	1710	2225	3510	NDOFC2600	7,5 l/s	1710	1450	NAN3200R	1710	1725	2435	NANAR3200	1710	1725	2435
DEPAUTO80	61-80	16000	2200	NDD6400	1950	2530	4862	NDOFC2600	7,5 l/s	1710	1450	NAN3800R	1710	1955	3104	NANAR3800	1710	2225	3510
DEPAUTO100	81-100	20000	3000	NDD7000	2250	2367	6711	NDOFC2600	7,5 l/s	1710	1450	NAN4600R	1710	2225	3510	NANAR4600	1710	2225	3510

TREATMENT EFFICIENCY

The treatment plant for car washes made up of a grit separator, an oil separator with coalescing filter, an anaerobic trickle filter and an aerated trickle filter with recirculation (installed as shown above) ensures that the concentrations of the final effluent are:

≤80 mg/l
SS

≤5 mg/l
Total Hydrocarbons

≤2 mg/l
Total surfactants

PLANTS FOR CAR WASHES

RE-USE OF THE TREATED WATER

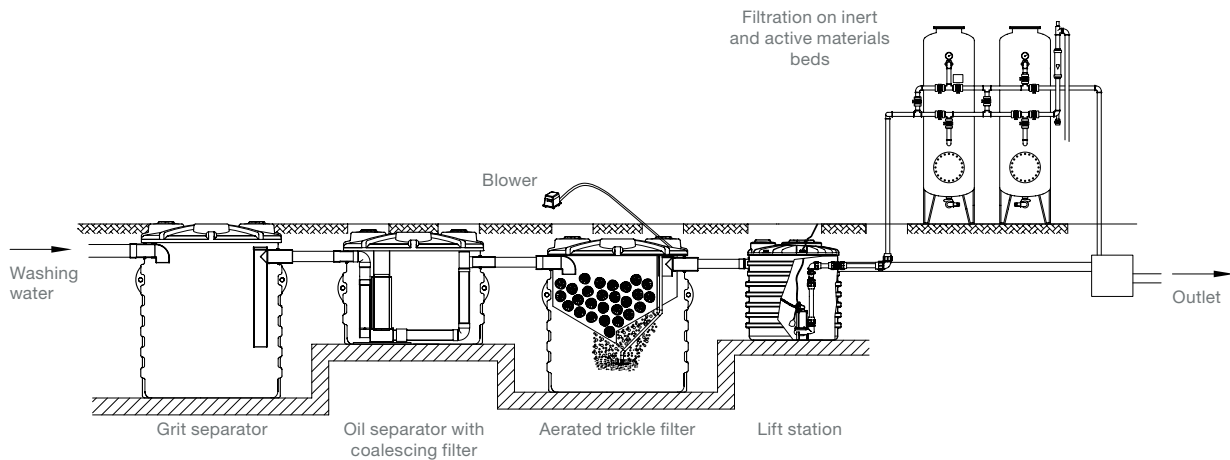

Item	Sizing			Plant composition																
	Cars/day n°	Hydraulic load l/d	Max Q l/h	Grit separator				Oil separator			Aerated trickle filter			Pumping station				External filtration		
				Model	Ø mm	H mm	V tot l	Model	Ø mm	H mm	Model	Ø mm	H mm	Model	Ø mm	H mm	V tot l	Model	L. x w mm	H mm
DEPAUTO10T4	0-10	2000	400	NDD 1500	1150	1720	1193	NDOFC1000 1,5 l/s	1150	1220	NANA 1000	1150	1220	NSOL 1000EC	1150	1220	900	FQCA05	900x40	1650
DEPAUTO20T4	11-20	4000	400	NDD 2600	1710	1450	1971	NDOFC1000 1,5 l/s	1150	1220	NANA 1500	1150	1720	NSOL 1000EC	1150	1220	900	FQCA05	900x40	1650
DEPAUTO30T4	21-30	6000	600	NDD 2600	1710	1450	1971	NDOFC1500 2 l/s	1150	1720	NANA 2100	1350	1975	NSOL 1000EC	1150	1220	900	FQCA08	1400x600	2000
DEPAUTO40T4	31-40	8000	800	NDD 3200	1710	1725	2435	NDOFC1000 3 l/s	1150	1220	NANA 2100	1350	1975	NSOL 1000EC	1150	1220	900	FQCA08	1400x600	2000
DEPAUTO50T4	41-50	10000	1200	NDD 3800	1710	1955	3026	NDOFC1500 4 l/s	1150	1720	NANA 3200	1710	1725	NSOL 1500EC	1150	1720	1400	FQCA1	1400x600	2000
DEPAUTO60T4	51-60	12000	1500	NDD 4600	1710	2225	3510	NDOFC2600 7,5 l/s	1710	1450	NANA 3200	1710	1725	NSOL 1500EC	1150	1720	1400	FQCA1	1400x600	2000
DEPAUTO80T4	61-80	16000	2200	NDD 6400	1950	2530	5100	NDOFC2600 7,5 l/s	1710	1450	NANA 3800	1710	1955	NSOL 3000EC	1710	1650	3000	FQCA2	1800x1000	2000
DEPAUTO100T4	81-100	20000	3000	NDD 7000	2250	2367	6711	NDOFC2600 7,5 l/s	1710	1450	NANA 4600	1710	2225	NSOL 3000EC	1710	1650	3000	FQCA2	1800x1000	2000

TREATMENT EFFICIENCY

The treatment plant for car washes made up of a grit separator, an oil separator with coalescing filter, an anaerobic trickle filter and an aerated trickle filter with recirculation (installed as shown above) ensures that the concentrations of the final effluent are:

≤25 mg/l
SS

≤2 mg/l
Total Hydrocarbons

≤0,5 mg/l
Total surfactants

EXTERNAL TREATMENT SYSTEMS FOR CAR WASHES

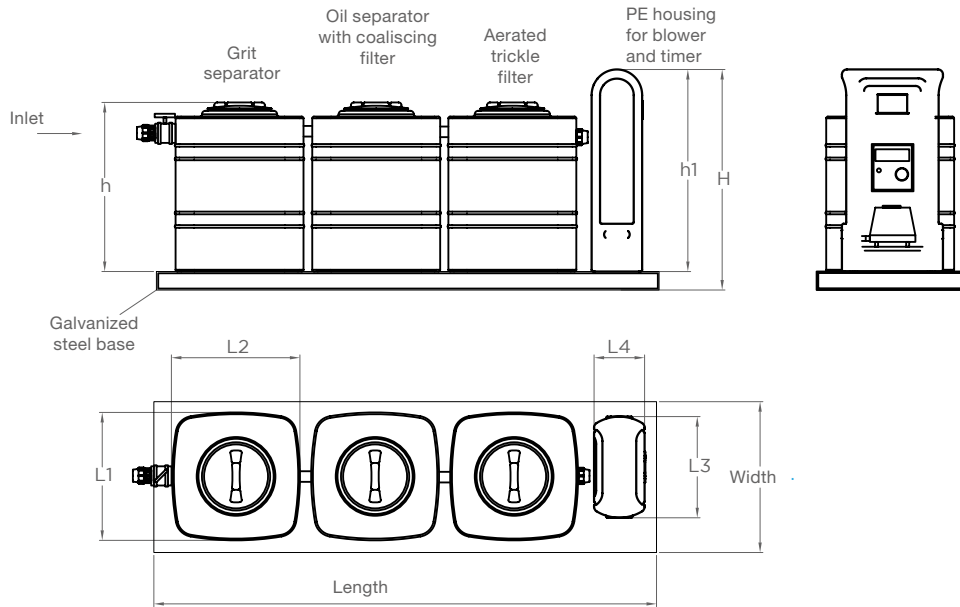

Item	Cars/day n°	Over all dimensions length x width x H mm	Grit separator/Oil separator/filter L1 x L2 x h mm	PE housing L3 x L4 x h1 mm	ØI - ØO mm	Total volume l	Blower W
DEPAUTOEST10	0-10	3400 x 1000 x 1300	760 x 760 x 980	300 x 600 x 1200	50-75	1350	31

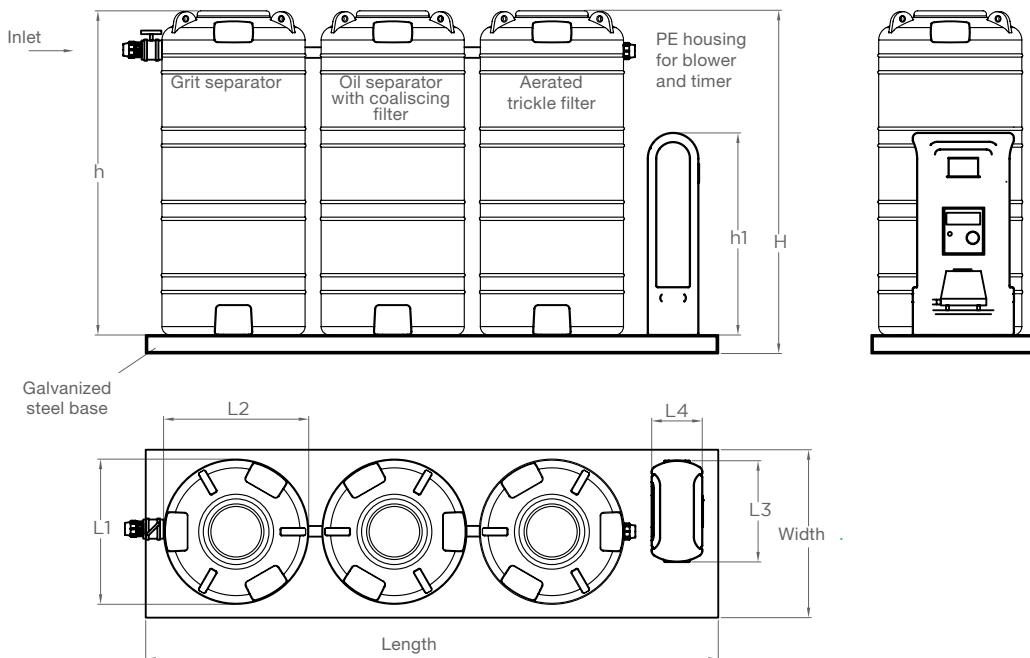

Item	Cars/day n°	Over all dimensions length x width x H mm	Grit separator/Oil separator/filter L1 x L2 x h mm	PE housing L3 x L4 x h1 mm	ØI - ØO mm	Total volume l	Blower W
DEPAUTOEST20	11-20	3400 x 1000 x 2003	850 x 850 x 1930	300 x 600 x 1200	50-75	2700	31

QUARTZITE AND ACTIVATED CHARCOAL FILTRATION



DESCRIPTION OF THE PLANT

Filtration plants constructed in a single block are the most rational and economic solution, for treatment of effluent characterised by pollution due to the presence of substances such as Suspended Solids, Hydrocarbons and Surfactants from: car washes, mechanical workshops, etc..

Their economy of operation relates to their ability to work without the need for operator intervention, which is only required for a few minutes/week, during the periodic wash-out operations.

The systems do not require chemical products for operation, so the salt content of the waste water is not altered. This is particularly advantageous in all cases when partial re-use of the treated water is required.

The filtration lines consist of two tanks or columns, equipped with n° 2 inspection covers, to allow periodic operations to load and replace the Quartzite and/or Activated Charcoal filter beds. These are extremely reliable and long-lasting finished products, that are able to withstand both the action of chemical agents and the weather. All the electromechanical equipment installed to support the plant feature maximum reliability, extreme simplicity of use and a minimum need for maintenance.

THE TREATMENT CYCLE FOR DISCHARGE TO LAND OR RE-USE

1. The water to be treated following external car washing activities are carried to the pre-treatment section, which consists of: grit separator, coalescing filter type oil separator and aerated trickle filter;
2. The waste water leaving the pre-treatment section enters a so-called homogenisation and storage tank, which contains the submerged electric pump used to power the plant.
3. The pre-treated water is then sent to the first stage of filtration, where they pass through a bed of ultra-fine Quartzite, with a suspended substance selection level of around 50µm.
4. After this, the clarified waste water moves on to the second stage of filtration, consisting of an Activated Charcoal bed. The feature of activated charcoal is its ability to retain, within its microporous structure, pollutants such as, for example, Surfactants, Hydrocarbons, Solvents etc.



Layout FQCA05 - FQCA08 - FQCA1

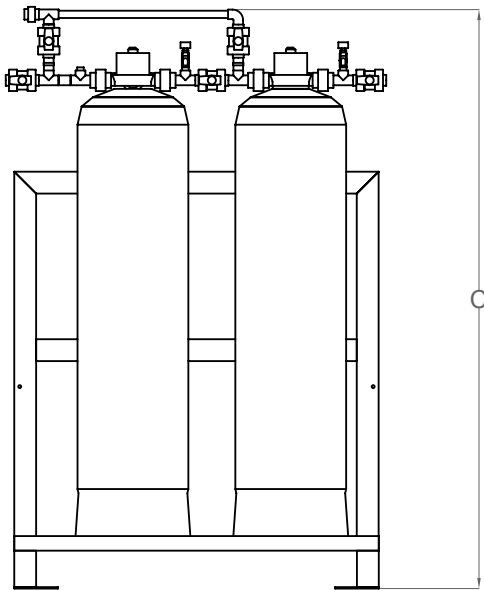

Layout FQCA2

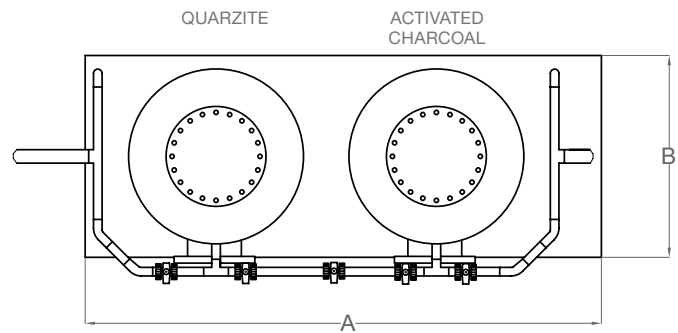
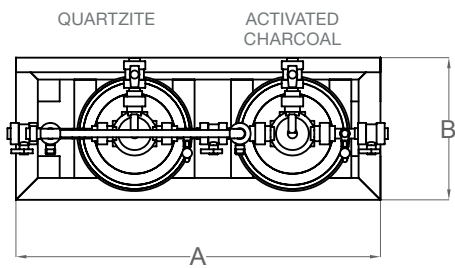
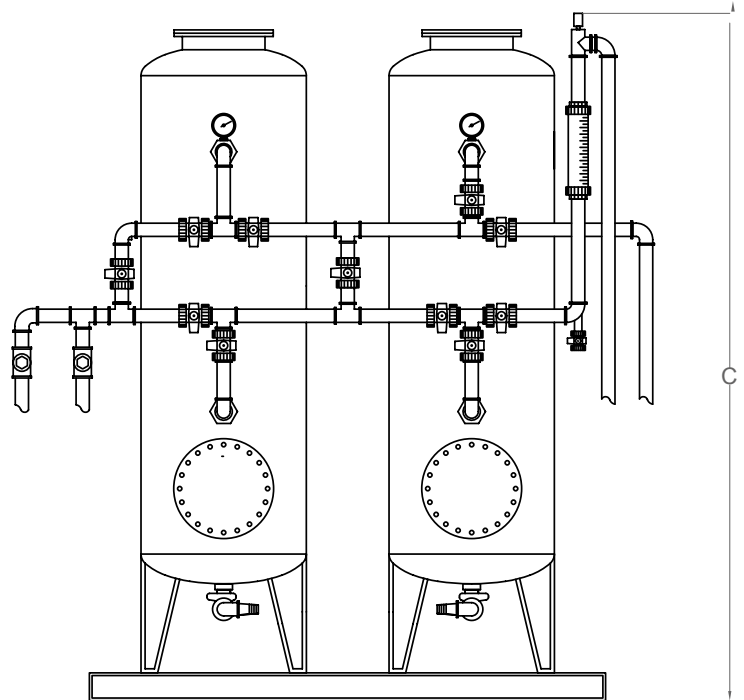

Item	Flow rate l/h	Overall SKID dimensions			Installed power Kw	Supply voltage V	Weight during service (kg)	Column material
		A cm	B cm	C cm				
FQCA05*	500	90	40	165	0,44	220	200	Fiberglass
FQCA08*	800	140	60	200	0,44	220	400	Fiberglass
FQCA1**	1500	140	60	200	1,1	380	500	Fiberglass
FQCA2**	3000	180	100	200	1,5	380	1200	Carbon steel

* supplied with submerged electric pump

** supplied with submerged electric panel

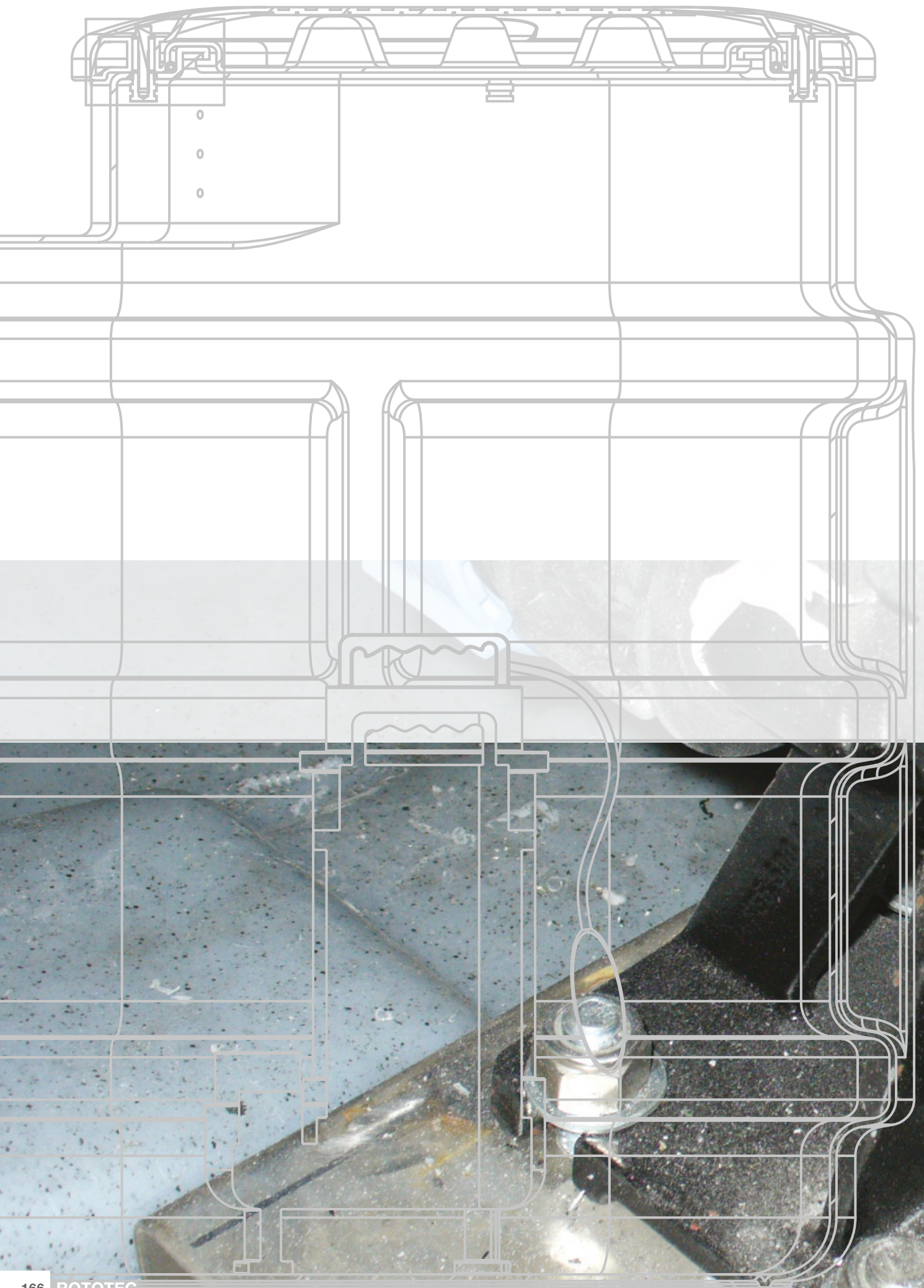

LIFT STATIONS



LIFT STATIONS



- 1 SUBMERSIBLE ELECTRIC PUMPS
- 2 STAINLESS STEEL DOWNPIPE AND QUICK-CONNECTION SYSTEM
- 3 COMMAND FLOATS
- 4 CAST IRON BALL CHECK-VALVE
- 5 OUTLET PIPES



SPECIFICATIONS

TECHNICAL CHARACTERISTICS

Sewage lift stations are systems that allow effluent to be lifted and transferred to stations located at higher levels (sewerage systems, treatment systems). They become necessary, for example, when the discharge level of a WC is lower than that of the treatment plant or sewerage pipes (cellars, underground premises, etc.) and when the hydraulic profile of the treatment system cannot work by gravity. The station consists of a linear polyethylene (LLDPE) storage tank of various sizes, with a submerged electric pump installed inside it. If the flow rates of waste water to be lifted are very high and/or variable and if the presence of a spare pump is necessary, dual pump models are provided. The pumps are connected to suitable electric panels so that, according to requirements, the start-up command can be either manual or automatic by means of start/stop float switches located inside the tank. Depending on need, the lift stations can be equipped with various types of pumps with different heads, flow rates and working pressures. For pumps possessing particular characteristics, contact the ROTOTEC technical office.

USE

To pump pre-treated and untreated waste water, rainwater, etc. to higher levels.

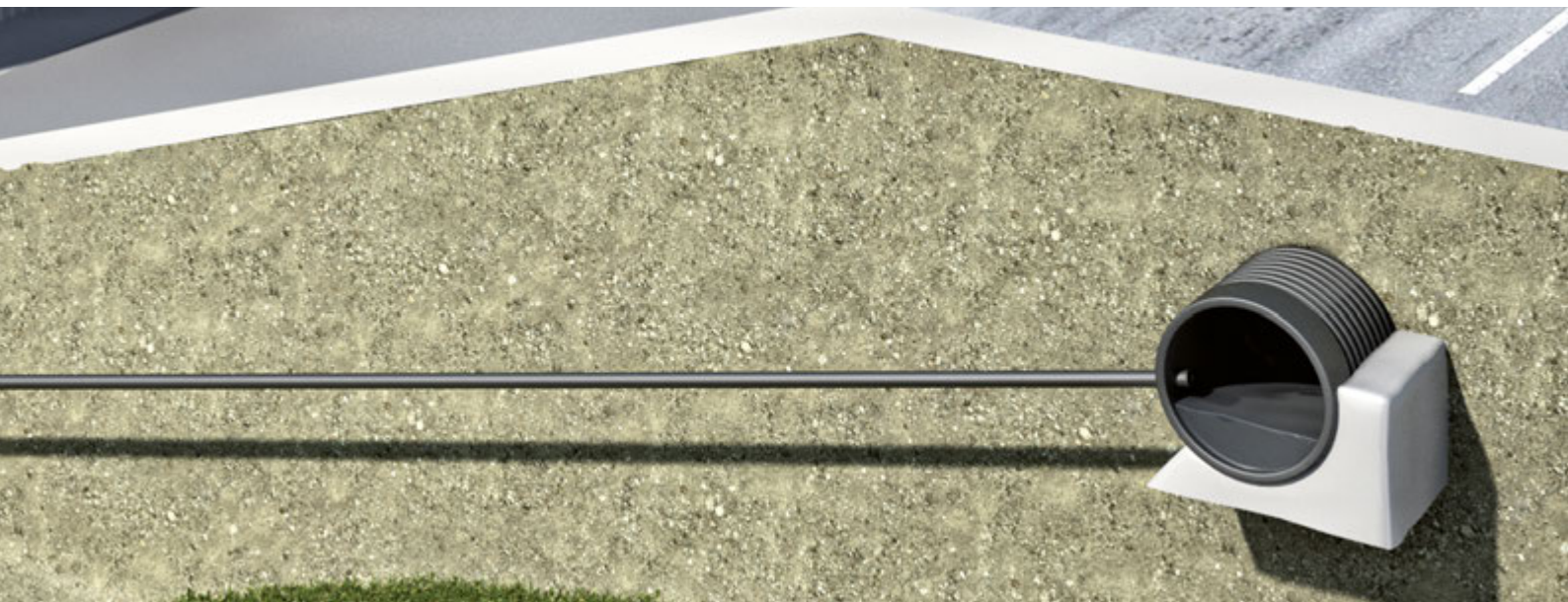

PICO SOL LIFT STATIONS

SMALL VOLUMES

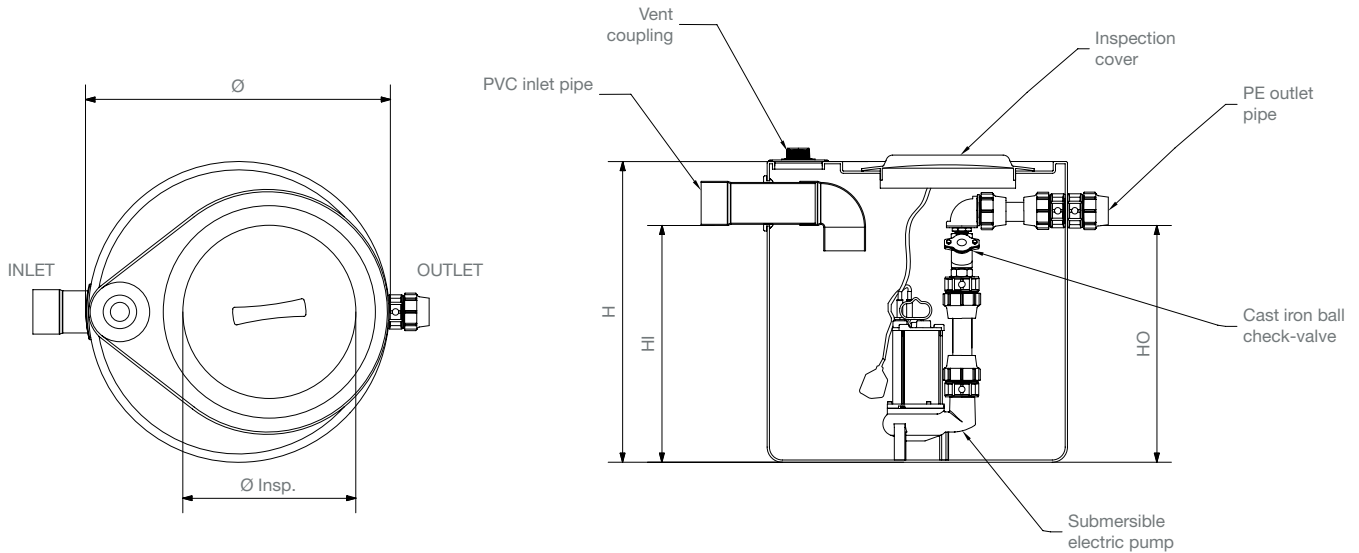

SINGLE PUMP

Item	Volume l	Ø mm	H mm	HI mm	HO mm	Ø I-O mm	Ø insp. mm	Pump	Impeller type	Kw	Flow rate l/min	Head m
SOL150	120	580	660	510	510	110-50	300	PNRG01	Vortex	0,3	10-140	6-1
SOL326	230	630	970	750	750	110-50	400	SM265	Vortex	0,55	0-300	8,5-1
SOL345	230	630	970	750	750	110-63	400	SM390	Vortex	0,75	0-500	10,5-1
SOL312	230	630	970	750	750	110-63	400	SM125	Grinder	1,18	0-110	30-3
SOL302	230	630	970	750	750	110-63	400	PMST2	Grinder	0,9	35-215	16-4
SOL526	305	790	790	625	625	110-50	400	SM265	Vortex	0,55	0-300	8,5-1
SOL545	305	790	790	625	625	110-63	400	SM390	Vortex	0,75	0-500	10,5-1
SOL563	305	790	790	625	625	110-63	400	SM635	2-channel	1,1	0-650	15-0
SOL512	305	790	790	625	625	110-63	400	SM125	Grinder	1,18	0-110	30-0
SOL502	305	790	790	625	625	110-63	400	PMST2	Grinder	0,9	35-215	16-4

Single and dual-pump lift stations, size 120 - 300 l

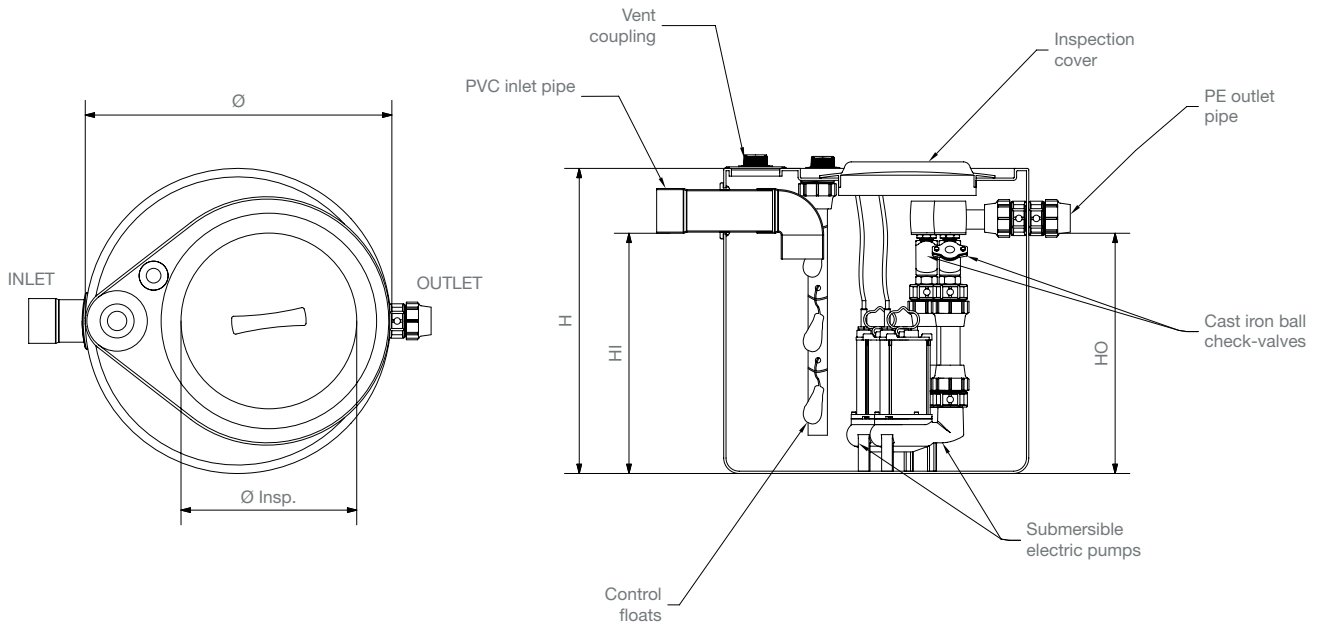

DUAL PUMP

Item	Volume l	Ø mm	H mm	HI mm	HO mm	Ø I-O mm	Ø insp. mm	Pump	Impeller type	Kw	Flow rate l/min	Head m
SOL526P2	305	790	790	625	625	110-63	400	SM265	Vortex	0,55	0-300	8,5-1
SOL545P2	305	790	790	625	625	110-63	400	SM390	Vortex	0,75	0-500	10,5-1
SOL563P2	305	790	790	625	625	110-63	400	SM635	2-channel	1,1	0-650	15-0
SOL512P2	305	790	790	625	625	110-63	400	SM125	Grinder	1,18	0-110	30-0
SOL502P2	305	790	790	625	625	110-63	400	PMST2	Grinder	0,9	35-215	16-4

ENNE SOL LIFT STATIONS

LARGE VOLUMES

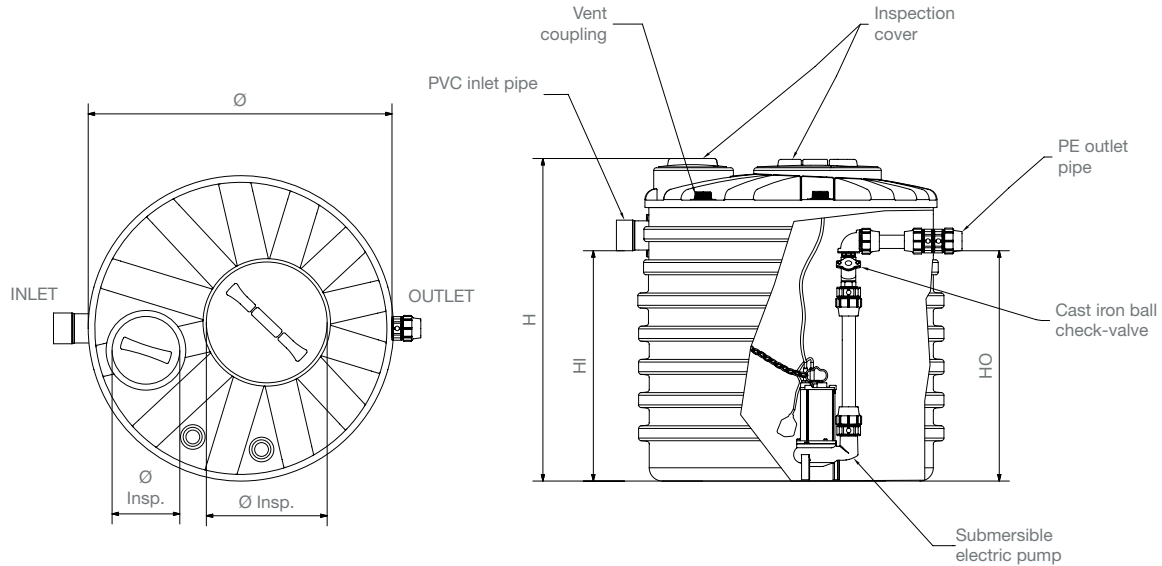

SINGLE PUMP

Item	Volume l	Ø mm	H mm	HI mm	HO mm	Ø I-O mm	Ø insp. mm	Pump	Impeller type	Kw	Flow rate l/min	Head m
NSOL1026	903	1150	1220	870	870	110-63	400-210	SM265	Vortex	0,55	0-300	8,5-1
NSOL1045	903	1150	1220	870	870	110-63	400-210	SM390	Vortex	0,75	0-500	10,5-1
NSOL1063	903	1150	1220	870	870	110-63	400-210	SM635	2-channel	1,1	0-650	15-0
NSOL1012	903	1150	1220	870	870	110-63	400-210	SM125	Grinder	1,18	0-110	30-3
NSOL1002	903	1150	1220	870	870	110-63	400-210	PMST2	Grinder	0,9	35-215	16-4
NSOL1526	1400	1150	1720	1360	1360	125-50	400-210	SM265	Vortex	0,55	0-300	8,5-1
NSOL1545	1400	1150	1720	1360	1360	125-63	400-210	SM390	Vortex	0,75	0-500	10,5-1
NSOL1563	1400	1150	1720	1360	1360	125-63	400-210	SM635	2-channel	1,1	0-650	15-0
NSOL1512	1400	1150	1720	1360	1360	125-63	400-210	SM125	Grinder	1,18	0-110	30-3
NSOL1502	1400	1150	1720	1360	1360	125-63	400-210	PMST2	Grinder	0,9	35-215	16-4
NSOL3026	3000	1710	1650	1355	1355	125-50	630	SM265	Vortex	0,55	0-300	8,5-1
NSOL3045	3000	1710	1650	1355	1355	125-63	630	SM390	Vortex	0,75	0-500	10,5-1
NSOL3063	3000	1710	1650	1355	1355	125-63	630	SM635	2-channel	1,1	0-650	15-0
NSOL3012	3000	1710	1650	1355	1355	125-63	630	SM125	Grinder	1,18	0-110	30-3
NSOL3002	3000	1710	1650	1355	1355	125-63	630	PMST2	Grinder	0,9	35-215	16-4
NSOL3004	3000	1710	1650	1355	1355	125-63	630	PMST4	Grinder	1,5	20-245	22-6

Single and dual-pump lift stations, size 900 - 3000 l

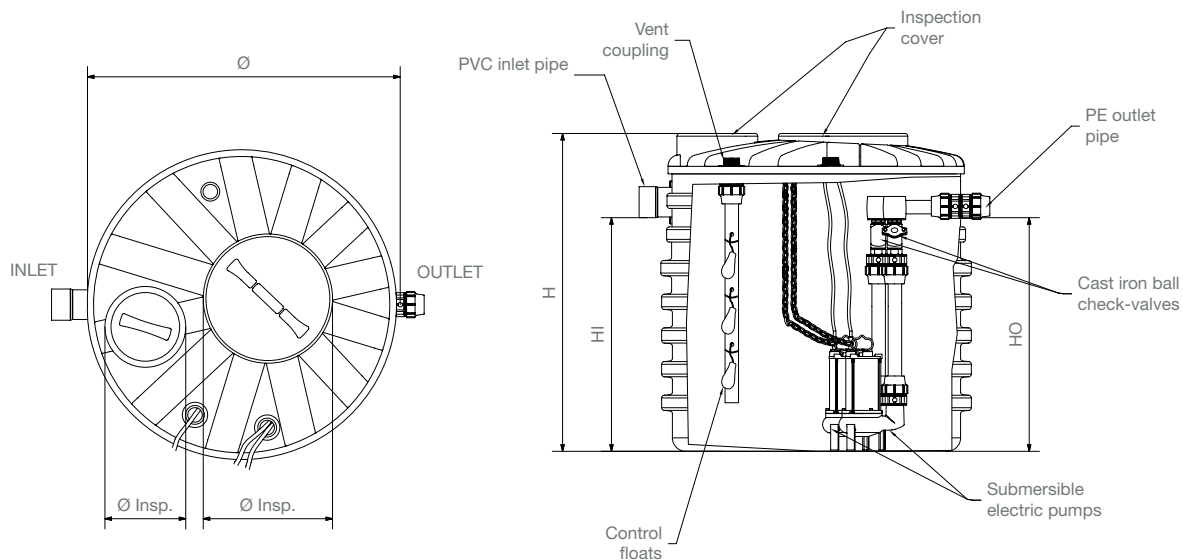

DUAL PUMP

Item	Volume l	Ø mm	H mm	HI mm	HO mm	Ø I-O mm	Ø insp. mm	Pump	Impeller type	Kw	Flow rate l/min	Head m
NSOL1026P2	903	1150	1220	870	870	110-63	400-210	SM265	Vortex	0,55	0-300	8,5-1
NSOL1045P2	903	1150	1220	870	870	110-63	400-210	SM390	Vortex	0,75	0-500	10,5-1
NSOL1063P2	903	1150	1220	870	870	110-63	400-210	SM635	2-channel	1,1	0-650	15-0
NSOL1012P2	903	1150	1220	870	870	110-63	400-210	SM125	Grinder	1,18	0-110	30-3
NSOL1002P2	903	1150	1220	870	870	110-63	400-210	PMST2	Grinder	0,9	35-215	16-4
NSOL1526P2	1400	1150	1720	1360	1360	125-63	400-210	SM265	Vortex	0,55	0-300	8,5-1
NSOL1545P2	1400	1150	1720	1360	1360	125-63	400-210	SM390	Vortex	0,75	0-500	10,5-1
NSOL1563P2	1400	1150	1720	1360	1360	125-63	400-210	SM635	2-channel	1,1	0-650	15-0
NSOL1512P2	1400	1150	1720	1360	1360	125-63	400-210	SM125	Grinder	1,18	0-110	30-3
NSOL1502P2	1400	1150	1720	1360	1360	125-63	400-210	PMST2	Grinder	0,9	35-215	16-4
NSOL3026P2	3000	1710	1650	1355	1355	125-63	630	SM265	Vortex	0,55	0-300	8,5-1
NSOL3045P2	3000	1710	1650	1355	1355	125-63	630	SM390	Vortex	0,75	0-500	10,5-1
NSOL3063P2	3000	1710	1650	1355	1355	125-63	630	SM635	2-channel	1,1	0-650	15-0
NSOL3012P2	3000	1710	1650	1355	1355	125-63	630	SM125	Grinder	1,18	0-110	30-3
NSOL3002P2	3000	1710	1650	1355	1355	125-63	630	PMST2	Grinder	0,9	35-215	16-4
NSOL3004P2	3000	1710	1650	1355	1355	125-63	630	PMST4	Grinder	1,5	20-245	22-6

TEKNOSOL LIFT STATIONS

SINGLE PUMP

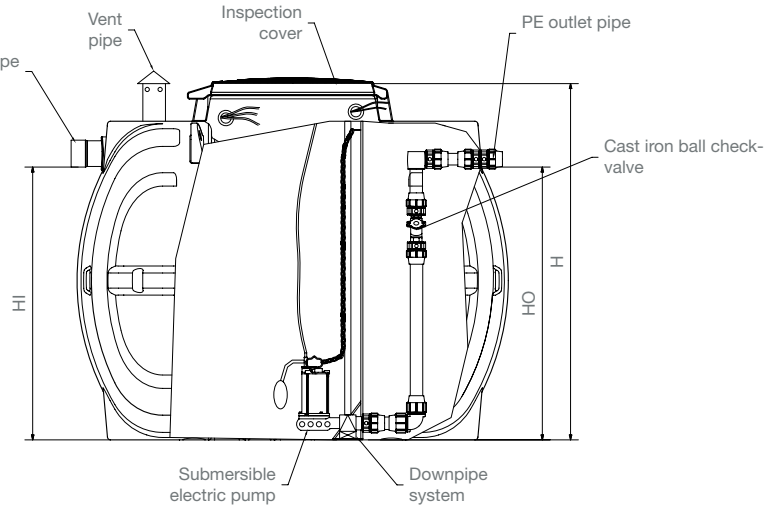
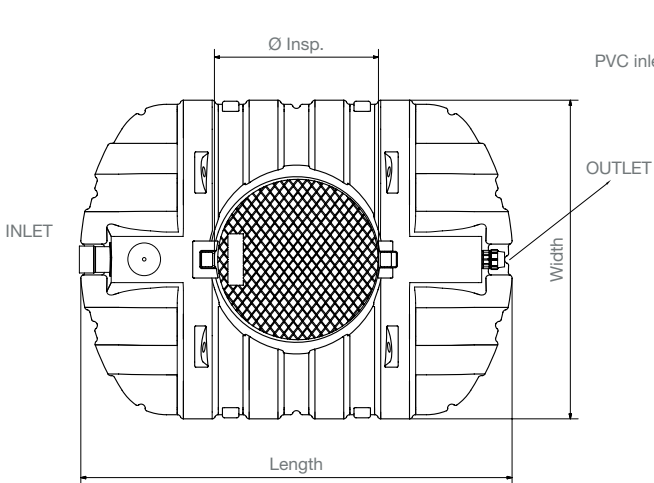
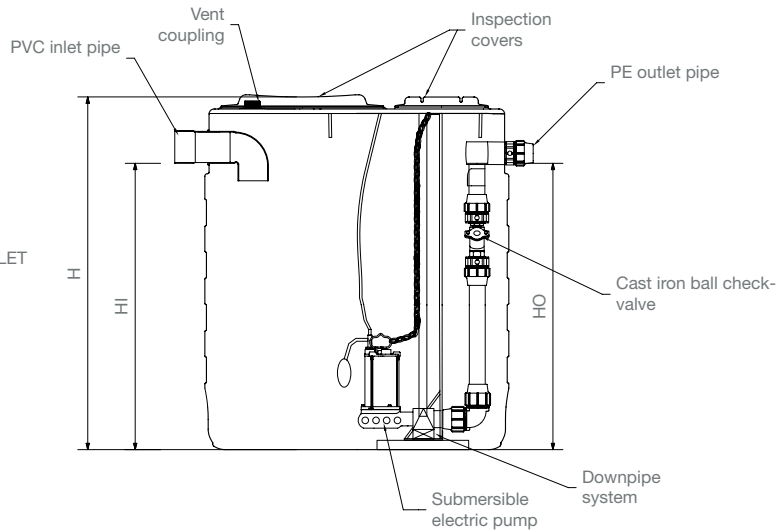
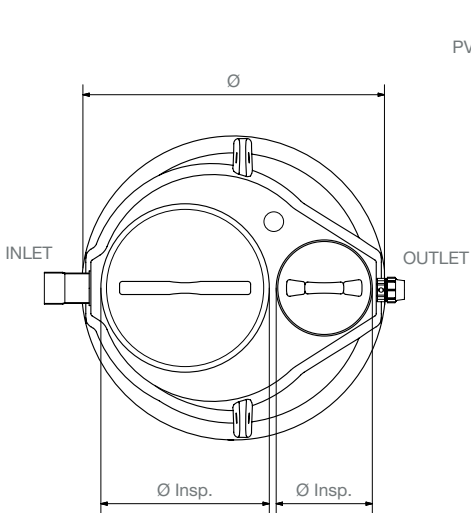
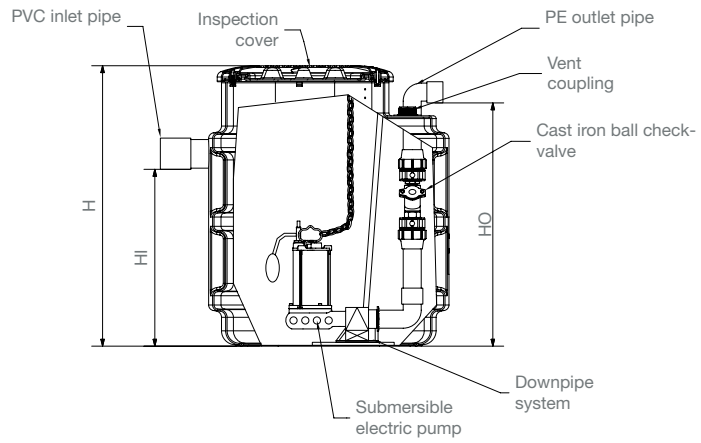
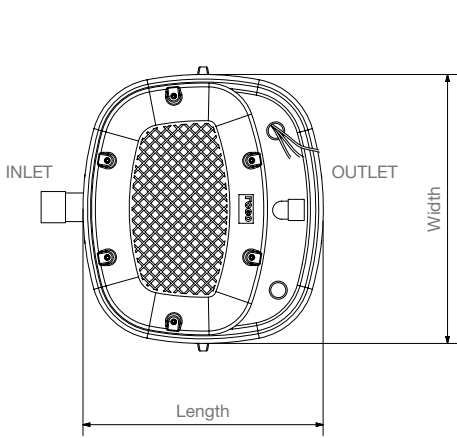

Single and dual-pump lift stations, size 400 - 3000 l with rapid connection-release-extraction system

Item	Volume l	Length mm	Width mm	H mm	HI mm	HO mm	Ø I-O mm	Ø insp. mm	Pump	Impeller type	Kw	Flow rate l/min	Head m
TSOL526	400	992	840	980	620	850	110-63	800x570	SM265	Vortex	0,55	0-300	8,5-1
TSOL545	400	992	840	980	620	850	110-63	800x570	SM390	Vortex	0,75	0-500	10,5-1
TSOL563	400	992	840	980	620	850	110-63	800x570	SM635	2-chan.	1,1	0-650	15-0
TSOL512	400	992	840	980	620	850	110-63	800x570	SM125	Grinder	1,18	0-110	30-3
TSOL502	400	992	840	980	620	850	110-63	800x570	PMST2	Grinder	0,9	35-215	16-4
TSOL726	650	992	840	1250	825	1125	110-63	800x570	SM265	Vortex	0,55	0-300	8,5-1
TSOL745	650	992	840	1250	825	1125	110-63	800x570	SM390	Vortex	0,75	0-500	10,5-1
TSOL763	650	992	840	1250	825	1125	110-63	800x570	SM635	2-chan.	1,1	0-650	15-0
TSOL712	650	992	840	1250	825	1125	110-63	800x570	SM125	Grinder	1,18	0-110	30-3
TSOL702	650	992	840	1250	825	1125	110-63	800x570	PMST2	Grinder	0,9	35-215	16-4
TSOL926	800	992	840	1525	1100	1390	110-63	800x570	SM265	Vortex	0,55	0-300	8,5-1
TSOL945	800	992	840	1525	1100	1390	110-63	800x570	SM390	Vortex	0,75	0-500	10,5-1
TSOL950	800	992	840	1525	1100	1390	110-63	800x570	SM590	Vortex	1,5	0-600	15-2
TSOL963	800	992	840	1525	1100	1390	110-63	800x570	SM635	2-chan.	1,1	0-650	15-0
TSOL912	800	992	840	1525	1100	1390	110-63	800x570	SM125	Grinder	1,18	0-110	30-3
TSOL902	800	992	840	1525	1100	1390	110-63	800x570	PMST2	Grinder	0,9	35-215	16-4

Item	Volume l	Ø mm	H mm	HI mm	HO mm	Ø I-O mm	Ø insp. mm	Pump	Impeller type	Kw	Flow rate l/min	Head m
TSOL1026	1000	1160	1300	1140	1140	125-63	600-200	SM265	Vortex	0,55	0-300	8,5-1
TSOL1045	1000	1160	1300	1140	1140	125-63	600-200	SM390	Vortex	0,75	0-500	10,5-1
TSOL1063	1000	1160	1300	1140	1140	125-63	600-200	SM635	2-chan.	1,1	0-650	15-0
TSOL1012	1000	1160	1300	1140	1140	125-63	600-200	SM125	Grinder	1,18	0-110	30-3
TSOL1002	1000	1160	1300	1140	1140	125-63	600-200	PMST2	Grinder	0,9	35-215	16-4
TSOL1004	1000	1160	1300	1100	1140	160-90	600-200	PMST4	Grinder	1,5	20-245	22-6
TSOL1005	1000	1160	1300	1140	1140	160-90	600-200	PMST5	Grinder	2,2	30-255	28-6
TSOL1526	1300	1160	1500	1300	1300	125-63	600-200	SM265	Vortex	0,55	0-300	8,5-1
TSOL1545	1300	1160	1500	1300	1300	125-63	600-200	SM390	Vortex	0,75	0-500	10,5-1
TSOL1563	1300	1160	1500	1300	1300	125-63	600-200	SM635	2-chan.	1,1	0-650	15-0
TSOL1512	1300	1160	1500	1300	1300	125-63	600-200	SM125	Grinder	1,18	0-110	30-3
TSOL1502	1300	1160	1500	1300	1300	125-63	600-200	PMST2	Grinder	0,9	35-215	16-4
TSOL1504	1300	1160	1500	1300	1300	160-90	600-200	PMST4	Grinder	1,5	20-245	22-6
TSOL1505	1300	1160	1500	1300	1300	160-90	600-200	PMST5	Grinder	2,2	30-255	28-6

Item	Volume l	Length mm	Width mm	H mm	HI mm	HO mm	Ø I-O mm	Ø insp. mm	Pump	Impeller type	Kw	Flow rate l/min	Head m
TSOL3026	3000	2090	1500	1720	1320	1320	125-50	630	SM265	Vortex	0,55	0-300	8,5-1
TSOL3045	3000	2090	1500	1720	1320	1320	125-63	630	SM390	Vortex	0,75	0-500	10,5-1
TSOL3063	3000	2090	1500	1720	1320	1320	125-63	630	SM635	2-chan.	1,1	0-650	15-0
TSOL3065	3000	2090	1500	1720	1320	1320	125-63	630	SM650	Vortex	1,5	0-600	9-3
TSOL3050	3000	2090	1500	1720	1320	1320	160-90	630	SM590	Vortex	1,5	0-600	15-2
TSOL3080	3000	2090	1500	1720	1320	1320	160-90	630	NRG09	Vortex	2,2	0-700	18-2
TSOL3011	3000	2090	1500	1720	1320	1320	160-90	630	SM1100	Vortex	2,2	0-900	13-1
TSOL3012	3000	2090	1500	1720	1320	1320	125-63	630	SM125	Grinder	1,18	0-110	30-3
TSOL3002	3000	2090	1500	1720	1320	1320	125-63	630	PMST2	Grinder	0,9	35-215	16-4
TSOL3004	3000	2090	1500	1720	1320	1320	160-90	630	PMST4	Grinder	1,5	20-245	22-6
TSOL3005	3000	2090	1500	1720	1320	1320	160-90	630	PMST5	Grinder	2,2	30-255	28-6

TEKNOSOL LIFT STATIONS

DUAL PUMP

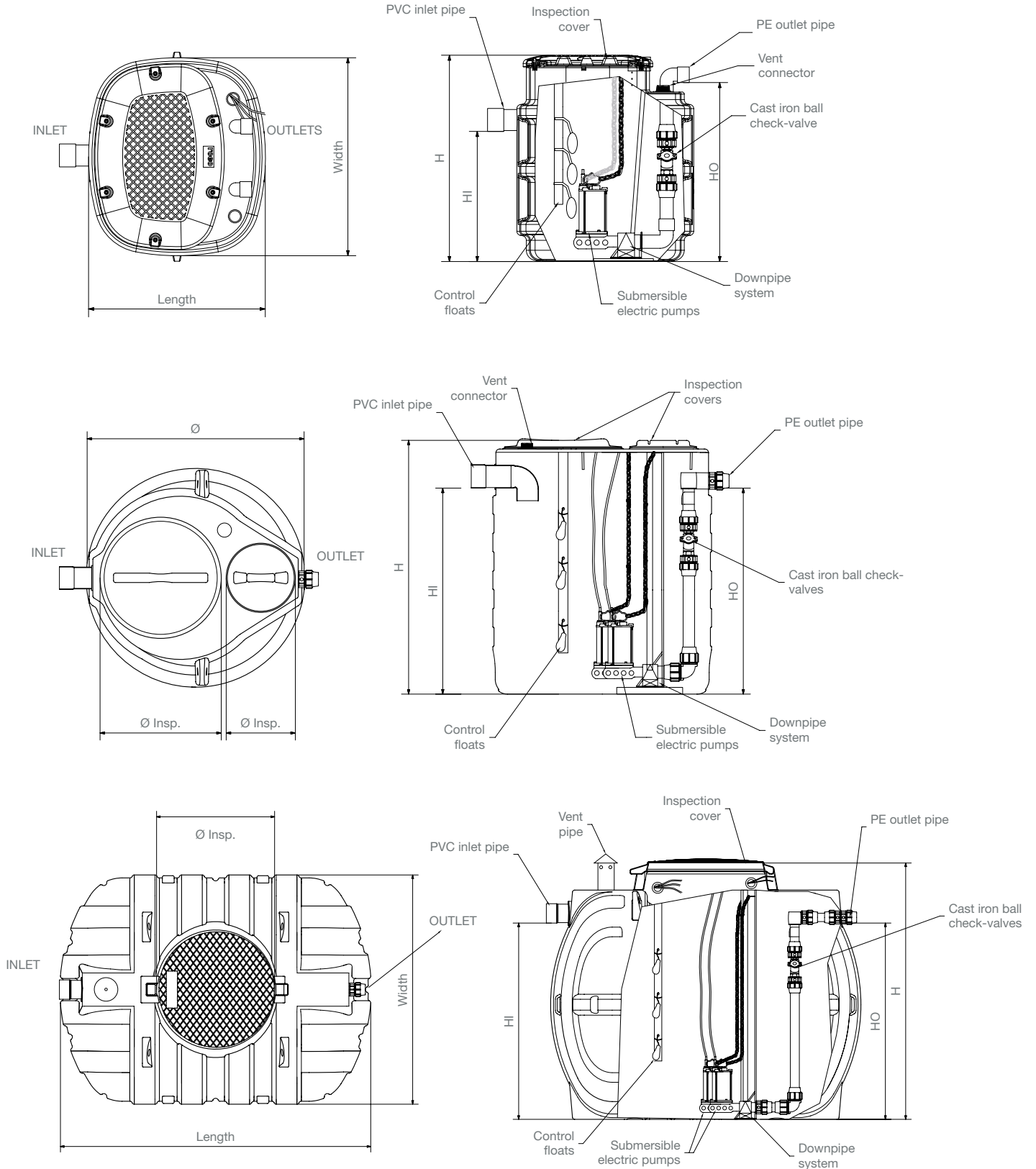

Single and dual-pump lift stations, size 400 - 3000 l with rapid connection-release-extraction system

Item	Volume l	Length mm	Width mm	H mm	HI mm	HO mm	Ø I-O mm	Ø insp. mm	Pump	Impeller type	Kw	Flow rate l/min	Head m
TSOL526P2	400	992	840	980	620	850	110-63	800x570	SM265	Vortex	0,55	0-300	8,5-1
TSOL545P2	400	992	840	980	620	850	110-63	800x570	SM390	Vortex	0,75	0-500	10,5-1
TSOL563P2	400	992	840	980	620	850	110-63	800x570	SM635	2-chan.	1,1	0-650	15-0
TSOL512P2	400	992	840	980	620	850	110-63	800x570	SM125	Grinder	1,18	0-110	30-3
TSOL502P2	400	992	840	980	620	850	110-63	800x570	PMST2	Grinder	0,9	35-215	16-4
TSOL726P2	650	992	840	1250	825	1125	110-63	800x570	SM265	Vortex	0,55	0-300	8,5-1
TSOL745P2	650	992	840	1250	825	1125	110-63	800x570	SM390	Vortex	0,75	0-500	10,5-1
TSOL763P2	650	992	840	1250	825	1125	110-63	800x570	SM635	2-chan.	1,1	0-650	15-0
TSOL712P2	650	992	840	1250	825	1125	110-63	800x570	SM125	Grinder	1,18	0-110	30-3
TSOL702P2	650	992	840	1250	825	1125	110-63	800x570	PMST2	Grinder	0,9	35-215	16-4
TSOL926P2	800	992	840	1525	1100	1390	110-63	800x570	SM265	Vortex	0,55	0-300	8,5-1
TSOL945P2	800	992	840	1525	1100	1390	110-63	800x570	SM390	Vortex	0,75	0-500	10,5-1
TSOL950P2	800	992	840	1525	1100	1390	110-63	800x570	SM590	Vortex	1,5	0-600	15-2
TSOL963P2	800	992	840	1525	1100	1390	110-63	800x570	SM635	2-chan.	1,1	0-650	15-0
TSOL912P2	800	992	840	1525	1100	1390	110-63	800x570	SM125	Grinder	1,18	0-110	30-3
TSOL902P2	800	992	840	1525	1100	1390	110-63	800x570	PMST2	Grinder	0,9	35-215	16-4

Item	Volume l	Ø mm	H mm	HI mm	HO mm	Ø I-O mm	Ø insp. mm	Pump	Impeller type	Kw	Flow rate l/min	Head m
TSOL1026P2	1000	1160	1300	1140	1140	125-63	600-200	SM265	Vortex	0,55	0-300	8,5-1
TSOL1045P2	1000	1160	1300	1140	1140	125-63	600-200	SM390	Vortex	0,75	0-500	10,5-1
TSOL1063P2	1000	1160	1300	1140	1140	125-63	600-200	SM635	2-chan.	1,1	0-650	15-0
TSOL1012P2	1000	1160	1300	1140	1140	125-63	600-200	SM125	Grinder	1,18	0-110	30-3
TSOL1002P2	1000	1160	1300	1140	1140	125-63	600-200	PMST2	Grinder	0,9	35-215	16-4
TSOL1004P2	1000	1160	1300	1100	1140	160-90	600-200	PMST4	Grinder	1,5	20-245	22-6
TSOL1005P2	1000	1160	1300	1100	1140	160-90	600-200	PMST5	Grinder	2,2	30-255	28-6
TSOL1526P2	1300	1160	1500	1300	1300	125-63	600-200	SM265	Vortex	0,55	0-300	8,5-1
TSOL1545P2	1300	1160	1500	1300	1300	125-63	600-200	SM390	Vortex	0,75	0-500	10,5-1
TSOL1563P2	1300	1160	1500	1300	1300	125-63	600-200	SM635	2-chan.	1,1	0-650	15-0
TSOL1512P2	1300	1160	1500	1300	1300	125-63	600-200	SM125	Grinder	1,18	0-110	30-3
TSOL1502P2	1300	1160	1500	1300	1300	125-63	600-200	PMST2	Grinder	0,9	35-215	16-4
TSOL1504P2	1300	1160	1500	1300	1300	160-90	600-200	PMST4	Grinder	1,5	20-245	22-6
TSOL1505P2	1300	1160	1500	1300	1300	160-90	600-200	PMST5	Grinder	2,2	30-255	28-6

Item	Volume l	Length mm	Width mm	H mm	HI mm	HO mm	Ø I-O mm	Ø insp. mm	Pump	Impeller type	Kw	Flow rate l/min	Head m
TSOL3026P2	3000	2090	1500	1720	1320	1320	125-63	630	SM265	Vortex	0,55	0-300	8,5-1
TSOL3045P2	3000	2090	1500	1720	1320	1320	125-63	630	SM390	Vortex	0,75	0-500	10,5-1
TSOL3063P2	3000	2090	1500	1720	1320	1320	125-63	630	SM635	2-chan.	1,1	0-650	15-0
TSOL3065P2	3000	2090	1500	1720	1320	1320	125-63	630	SM650	Vortex	1,5	0-600	9-3
TSOL3050P2	3000	2090	1500	1720	1320	1320	160-90	630	SM590	Vortex	1,5	0-600	15-2
TSOL3080P2	3000	2090	1500	1720	1320	1320	160-90	630	NRG09	Vortex	2,2	0-700	18-2
TSOL3011P2	3000	2090	1500	1720	1320	1320	160-90	630	SM1100	Vortex	2,2	0-900	13-1
TSOL3012P2	3000	2090	1500	1720	1320	1320	125-63	630	SM125	Grinder	1,18	0-110	30-3
TSOL3002P2	3000	2090	1500	1720	1320	1320	125-63	630	PMST2	Grinder	0,9	35-215	16-4
TSOL3004P2	3000	2090	1500	1720	1320	1320	160-90	630	PMST4	Grinder	1,5	20-245	22-6
TSOL3005P2	3000	2090	1500	1720	1320	1320	160-90	630	PMST5	Grinder	2,2	30-255	28-6

PUMPS FOR LIFT STATIONS

MULTI-CHANNEL IMPELLER PUMPS

Submersible electric pumps with multichannel open shim impeller. These are ideal to pump clear and turbid water without solid and stringy matter, for example rainwater and treated waste water.

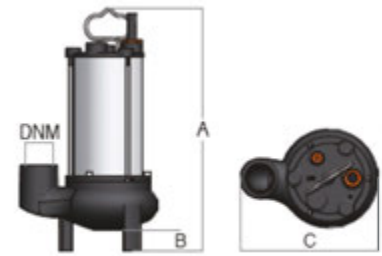

Pump	HP	KW	A	μF	DNM	A mm	B mm	C mm	Weight Kg	Flow rate l/min	Head m
TCN4	1	0,75	4,8	20	1" ½	317	57	188	14,5	35-380	12-1
SM635SL	1,5	1,1	7,3	25	2"	466	60	250	19,3	0-650	15-0

PUMPS WITH VORTEX IMPELLER

Submersible electric pumps with vortex impeller. These are ideal for low head (<8 m) pumping of sewage, including sewage with solid or stringy matter in suspension, such as water from marshy land and untreated domestic sewage

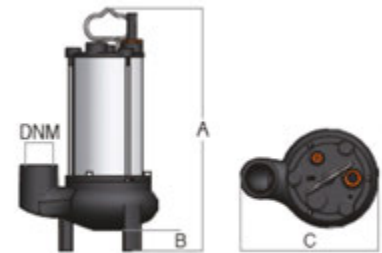

Pump	HP	KW	A	μF	DNM	A mm	B mm	C mm	Weight Kg	Flow rate l/min	Head m
PNRG01	0,4	0,3	2,2	8	1 ¼	263	42	151	9	20-155	6-1
SM265	0,75	0,55	4,2	16	1" ½	400	50	230	16,5	0-300	8,5-1
SM390	1	0,75	5,5	20	2"	450	65	235	18,8	0-500	10,5-1
SM650L	2	1,5	12	31,5	2" ½	445	91	334	22	0-600	9-3
SM590	2	1,5	10,5	31,5	2"	496	162	198	18,2	0-600	15-2
NRG09 (three-phase)	3	2,2	5,3	-	2"	445	184	232	26	0-700	18-2
SM1100/65 (three-phase)	3	2,2	6	-	3"	584	65	417	40	0-900	13-1

PUMPS WITH GRINDER IMPELLER

Submersible electric pumps with grinder impeller. These are ideal for pumping of sewage, including sewage with solid or stringy matter in suspension, such as water from marshy land and untreated domestic sewage. Reduction of the solids into small fragments and the high pressure generated by the pump allow considerable differences in level to be overcome.

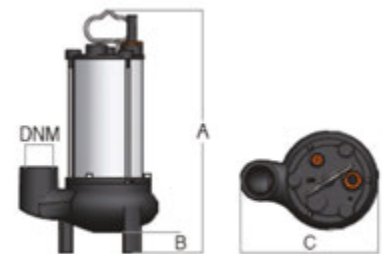

Pompa	HP	KW	A	μF	DNM	A mm	B mm	C mm	Peso Kg	Portata lt/min	Preval mt
SM125GR	1,6	1,18	9,2	35	1" ½	416	29	240	20,5	0-110	30-3
PMST2	1,2	0,9	7,3	30+70	1" ¼	385	78	205	23	35-215	16-4
PMST4	2	1,5	11	40+70	40 mm	442	92	268	38	20-245	22-6
PMST5 (three-phase)	3	2,2	5,3	-	40 mm	442	92	268	40	30-255	28-6

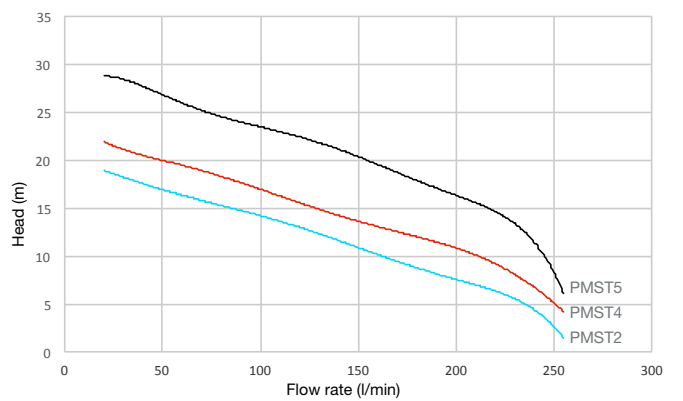
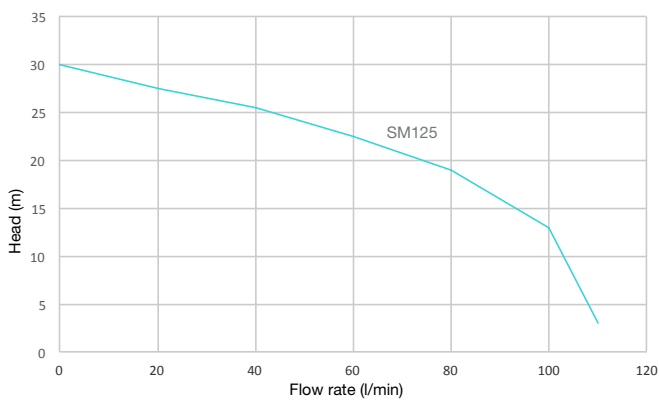
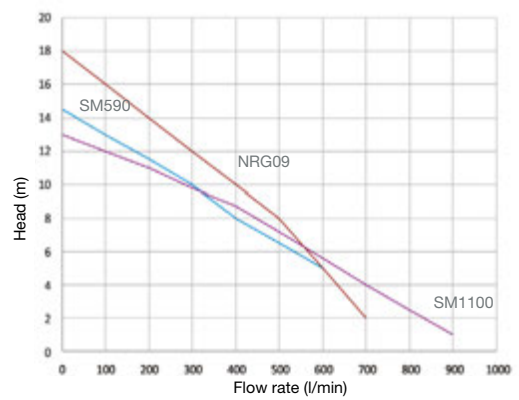
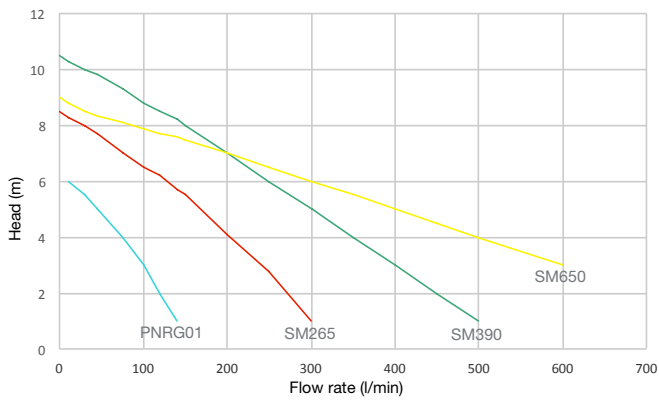
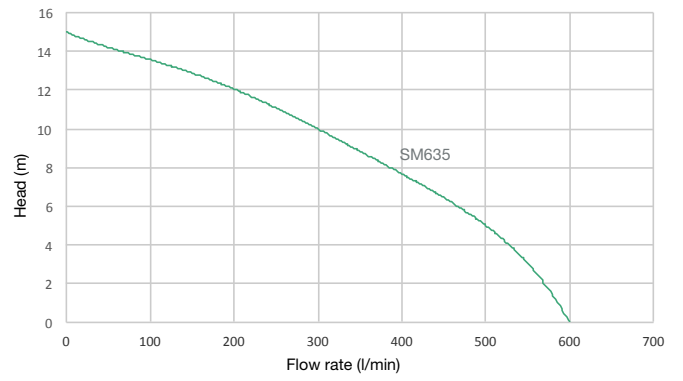
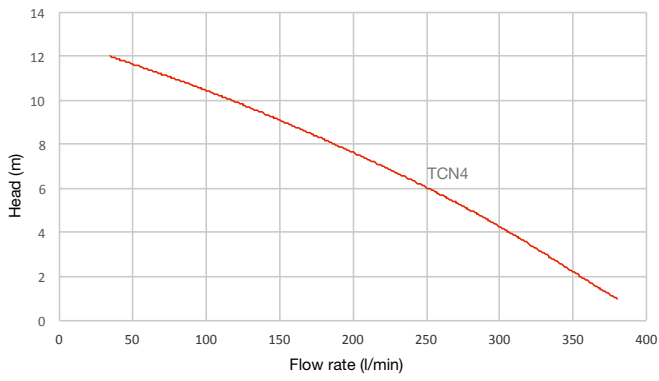

PANELS FOR LIFT STATIONS



DIRECT ELECTRIC PANEL FOR SINGLE PUMP LIFT STATION

Item	Pump power		Current		Size			Weight Kg
	KW	HP	from (A)	to (A)	Height mm	Length mm	Depth mm	
QCSOLP1	0,37-2,2	0,5-3	2	16	340	240	170	1,5
QCSOLP1T	0,55-3,7	0,75-5,5	2	8	340	240	170	2

FUNCTION

pump start-up panel for sewage lift station. The start-up command can be either manual or automatic by means of start/stop float switches in the tank. The electric panel is fitted with visual alarms (warning lights) and is set-up for connecting a self-powered audible alarm (mod. QALARM) to signal faults, including in the presence of a power cut. The power supply can be single-phase (domestic type: 230 V) or three-phase (industrial type: 400 V).



DIRECT ELECTRIC PANEL FOR DUAL PUMP LIFT STATION

Item	Pump power		Current		Size			Weight Kg
	KW	HP	from (A)	to (A)	Height mm	Length mm	Depth mm	
QCSOLP2	0,37-2,2	0,5-3	2	16	340	240	170	4
QCSOLP2T	0,55-3,7	0,75-5,5	2	8	340	240	170	5,5

FUNCTION

pump start-up panel enabling activation of alternate or simultaneous operation mode of n. 2 pumps for sewage lift station. The start-up command can be either manual or automatic by means of a series of start/stop float switches positioned at different levels in the tank. The electric panel is fitted with visual alarms (warning lights) and is set-up for connecting an audible alarm (mod. QALARM) to signal faults. The power supply can be single-phase (domestic type: 230 V) or three-phase (industrial type: 400 V).



ALARM UNIT ELECTRIC PANEL

Item	Power supply V	Float			Weight Kg
		Height mm	Length mm	Depth mm	
QALARM	220	160	160	140	0,5

FUNCTION

audible/visual alarm for fault signalling. The unit is set-up for connecting to the electric start-up panels of sewage pumps and level floats (overflow). For installation in lift stations.



TECHNICAL SECTION - LIFT STATIONS

TECHNICAL CHARACTERISTICS

Sewage lift stations are systems that allow effluent to be lifted and transferred to stations located at higher levels (sewerage systems, treatment systems). They become necessary, for example, when the discharge level of a WC is lower than that of the treatment plant or sewerage pipes (cellars, underground premises, etc.) and when the hydraulic profile of the treatment system cannot work by gravity.

The station consists of a linear polyethylene (LLDPE) storage tank of various sizes, with a **submerged electric pump installed** inside it. The pump is connected to the tank by a chain to facilitate its removal, and the inlet pipe is fitted with a **cast iron ball check-valve**.

If the flow rates of waste water to be lifted are very high and/or variable and if the presence of a spare pump is necessary, **dual pump models** are provided. The pumps are connected to suitable electric panels so that, according to requirements, the start-up command can be either manual or automatic by means of start/stop float switches located inside the tank.

The dual pump models are provided with an **electric panel** allowing alternating or simultaneous operation of the 2 pumps to be activated. The electric panel can also be fitted with visual alarms (warning lights) and is set-up for connecting an audible alarm device. The power supply can be single-phase (domestic type: 230 V) or three-phase (industrial type: 400 V). Depending on need, the lift stations can be equipped with various types of pumps with different heads, flow rates and working pressures. For pumps possessing particular characteristics, contact the ROTOTEC technical office. A **three-phase version** of the electric pumps and electric panels can be supplied on request.

USE AND MAINTENANCE

All maintenance operations must be carried out with the pump disconnected from the power supply. The pump must be disconnected by trained technicians, so that there is no risk of it starting accidentally.

The maintenance recommendations indicated are not to be understood as “do-it-yourself” operations, as they require specific technical knowledge. A service contract with a specialist technician will ensure you receive the best technical assistance at all times.

In order for a lift station to function efficiently, it is important that the **most suitable pump for satisfying the specific requirements** is selected during the design phase. To this end, a few important parameters such as the origin and characteristics of the effluent to treat, the function of the lift station, **the head and linear distance to the receiver** must be evaluated.

Even when the pump is capable of handling solid and stringy matter (**vortex impeller**) it is nevertheless advisable to install a primary sedimentation system (e.g. septic tank) upstream or a sewage screening system that can separate non-shreddable materials such as rags, plastics, etc. The installation of such a system is essential when pumps with **2-channel impeller** are installed.

Under normal operating conditions, the electric pumps do not require any maintenance operations.

MANAGEMENT

WHAT TO DO	WHEN	HOW
Inspect the lifting station	Every 6 months	Unscrew the covers on the inspection holes and check the level of sediments on the bottom
Check the seal on pipes, connectors and gaskets	Every 6 months	Check inlet and outlet pipes
Check vent pipe	Every 6 months	If anything is obstructing the free flow of air, remove it
Check the pumping system	Every 12 months	Extract the pump*, clean the inlet to remove any debris, assess the state of the impeller, the electric cable and the floats
Remove bottom sediment and clean the inlet and outlet pipes	Every 6 / 12 months	Contact a licensed waste disposal company

* To dismantle a pump it is necessary to **unfasten the compression fitting** on the pump delivery pipe, then extract the pump, with the aid of the **lifting chain**.

WARNINGS

- provide for a **vent of a size suited** to the power of the pump, to prevent the formation of a vacuum in the tank;
- Only start the electric pump once it has been installed, **do not attempt a dry start**;
- Do not remove the suction filter, if there is one, for any reason whatsoever;
- Avoid operating the pump in the horizontal position. The pump can only function in the **vertical position** (with the motor at the top and the pump part at the bottom);
- On the **three-phase version**, the correct direction of rotation is indicated by the arrow stamped on the pump body and on the identification plate.
- If the electric pump is not properly fixed, it may become unsteady or topple over on start-up due to the starting torque;
- Never use the electric pump to **pump dangerous liquids** (toxic, flammable, etc...);
- in the event of a maintenance operation of any kind, always comply with the **safety regulations** regarding operations within closed waste water treatment areas, and with the general technical procedures applicable.
- provide for a **vent of a size suited** to the power of the pump, to prevent the formation of a vacuum in the tank;
- Only start the electric pump once it has been installed, **do not attempt a dry start**;
- Do not remove the suction filter, if there is one, for any reason whatsoever;
- Avoid operating the pump in the horizontal position. The pump can only function in the **vertical position** (with the motor at the top and the pump part at the bottom)

RISK OF ELECTRIC SHOCK

- Do not transport or handle the pump using the electric power supply cable.
- Never move the electric pump when it is operating or with the power cable connected to the power supply;
- Before connecting up the pump, make sure that the power supply network is properly earthed;
- Before carrying out any type of control or maintenance operation, disconnect the power supply;
- Never start the pump if you are in contact with the liquid to be pumped;
- Always ensure that the pump is checked and repaired by authorised personnel only. Unauthorised repairs might make the product unsafe and/or dangerous;
- Never put your hands or other objects into the pumped liquid inlets or outlets in the vicinity of the impellers, if present, as these are moving parts;



CHAMBERS



CHAMBERS

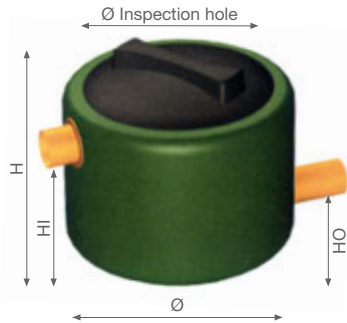

SAMPLING CHAMBER

Item	Ø mm	H mm	HI mm	HO mm	Ø I/O mm	Ø Cover mm	Cover	Extensions
PPF 50	430	465	260	37	125*	300	CC300	PP35
PPF 500	790	790	618	50	125**	400	CC400	PP45

FUNCTION

Installation downstream of a sewage treatment plant allows effluent samples to be taken for analysis purposes.

* on request I/O 110 mm

** on request I/O 160 mm

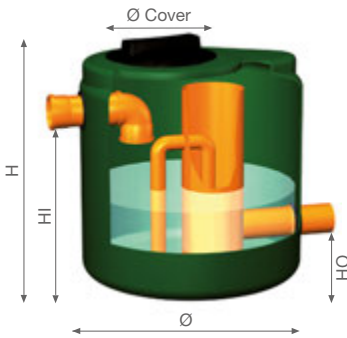

DOSING SIPHON CHAMBER

Item	Ø mm	H mm	HI mm	HO mm	Ø I/O mm	Ø Cover mm	Cover	Extensions	Dosing siphon volume l
PDC 500	790	790	640	100	110	400	CC400	PP45	~ 250
PDC 1200	1240	1250	1080	130	125 / 110	400	CC400	PP45	~ 1000

FUNCTION

essential upstream of a sub-irrigation system with dispersion pipe, for even distribution of the treated effluent along the whole length of the dispersion pipe.

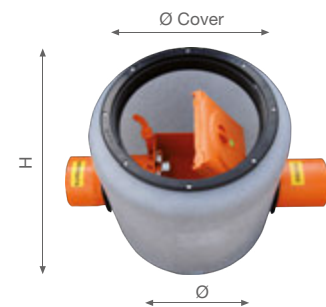

NON-RETURN VALVE/ANTI-RAT CHAMBER

Item	Ø mm	H mm	HI mm	HO mm	Ø I/O mm	Ø Cover mm	Cover	Extensions
PAR 50	430	430	90	60	125	300	CC300	PP35

FUNCTION

When installed on a waste water drain pipe, this device stops any backflow from the main sewer and prevents the basement from being flooded. At the same time, the valve prevents animals (e.g. rats) from running up the pipe.

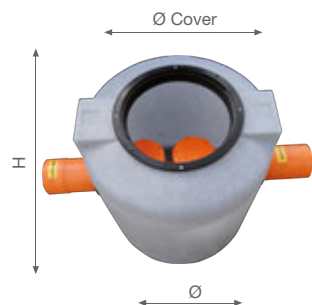

SIPHON CHAMBER

Item	Ø mm	H mm	Ø I/O mm	Ø Cover mm	Cover	Extensions
PSIF 150	582	660	125	300	CC300	PP35

FUNCTION

Sewage siphon.

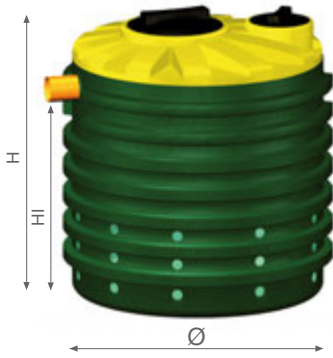

SOAKAWAY CHAMBER

Item	Ø mm	H mm	HI mm	ØI mm	Ø Cover mm	Cover	Extensions
NPD 1000	1150	1220	890	110	400 - 210	CC400-CC200	PP45 / PP30
NPD 1500	1150	1720	1370	110	400 - 210	CC400-CC200	PP45 / PP30
NPD 2100	1350	1975	1540	110	400 - 300	CC400-CC200	PP45 / PP35
NPD 4000	1710	2150	1850	125	630	TAP800	PP77
NPD 8000	2270	2750	2410	125	630	TAP800	PP77

FUNCTION

The holes present at the base of the tank allow previously treated effluent to soak away through the surface layers of soil.

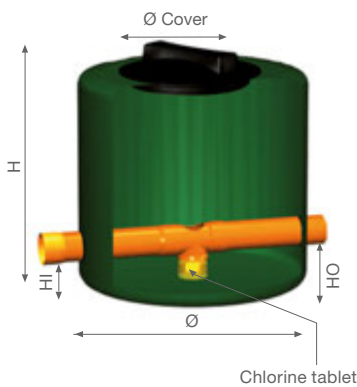

CHLORINATOR CHAMBER

Item	Ø mm	H mm	HI mm	HO mm	Ø I/O mm	Ø Cover mm	Cover	Extensions
PCL 50	430	430	100	90	110	300	CC300	PP35
PCL 150	580	660	100	90	110	300	CC300	PP35

FUNCTION

The chamber has a housing for a chlorine tablet. Consequently, when installed downstream of a treatment plant, it disinfects the final effluent prior to discharging to the receptor.



DOSING CHAMBER

Item	Tank volume l	Ø mm	H mm	Ø Cover mm	Cover	Flow rate capacity l/h	Working pressure bar	Absorbed power W
PDOS 300	300	630	1100	210	CC200	1	5	32

FUNCTION

Dosing sodium hypochlorite (or disinfecting agent) at a constant flow in the disinfection tanks or pipes.

DOSING PUMP

- Plastic container in reinforced PP with protection grade IP55;
- Pump body with manual air vent;
- Compact size;
- Fixing bracket for base or wall mounting;
- Operating status signalling led;
- Silent version available on request;
- The flow rate is adjusted by changing the frequency, using a dial, with a scale of 0-100%.



CHAMBERS

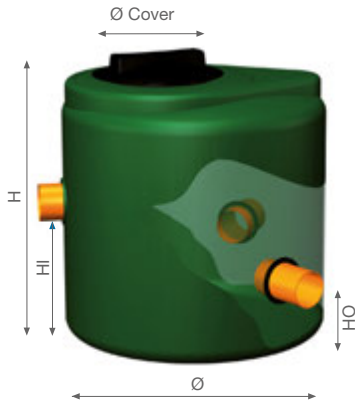

DISTRIBUTION CHAMBER

Item	Ø mm	H mm	Ø I/O mm	HI mm	HO mm	Ø Cover mm	Cover	Extensions
PRE 500	790	790	125	to be defined according to use		400	CC400	PP45
PRU 500	790	790	125			400	CC400	PP45

FUNCTION

The distribution chambers are installed upstream and downstream of a treatment system laid out in two parallel lines. The upstream chamber divides the effluent into two equal flows, while the downstream chamber combines the two treatment flow lines into one outlet. This latter chamber can also function as a sampling point.

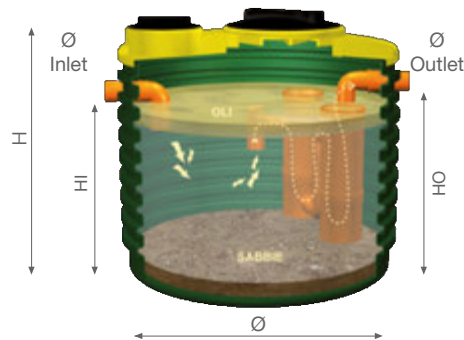

OIL ABSORPTION CHAMBER

Item	Ø mm	H mm	HI mm	HO mm	Ø I/O mm	Useful Vol. l
POLSS1000	1150	1220	880	860	125	850

FUNCTION

A special fabric is present in a removable stainless steel grid. It is able to absorb and block the particles of oil in the effluent. It is used downstream of stormwater systems of oil separators, to block any residual oil that may escape normal treatment.

Ring nuts to dismantle and inspect litre counter

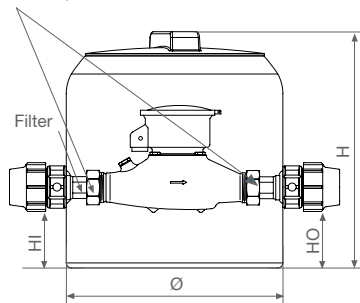

LITRE COUNTER CHAMBER



FUNCTION

When installed on a pressurised pipe this allows measurement of the amount of water passing through the pipe itself. It is often required in stormwater runoff systems, downstream of the storage and delivery tank.

Item	Ø mm	H mm	HI mm	HO mm	Cover	Extensions	Calibre mm	Max. flow rate m³/h	Nominal flow rate m³/h	Min. flow rate l/h	Sensitivity l/h	Readings min. l
PCLT 50	430	430	120	120	CC300	PP 35	32	12	6	120	15	0,05



UNDERGROUND **INSTALLATION**



HANDLING



Corrugated tanks model Cisterna



Corrugated tanks model Canotto



Corrugated tanks model Panettone



Smooth tanks model Cisterna



Smooth tanks model Panettone



Modular tanks



Corrugated septic tanks



Corrugated septic tanks model Elipse



Reinforced septic tanks



Smooth septic tanks



Septic tanks with separation baffles

PROHIBITIONS

- a) It is absolutely forbidden to install underground tanks above ground.
- b) It is absolutely prohibited to use the tanks for storing industrial waste or liquids containing chemical substances or mixtures that are not compatible with polyethylene (see compatibility table supplied by Rototec).
- c) Underground tanks are NOT suitable and must NOT be used for storing diesel fuel.

WARNINGS

- a) When carrying out any of the operations, comply with Legislative Decree 81/08 and subsequent amendments governing safety at temporary and mobile construction sites.
- b) On arrival of the goods, carefully check the material to make sure it corresponds to the order and the project data. Any defects and/or damage due to transport must be reported immediately. Contact the company directly by telephone, fax or e-mail.
- c) Check that the product is provided with all the standard documentation (technical data sheets, installation instructions, etc...). Inform the company of any missing items. A copy will be sent immediately.
- d) Make sure that the gaskets, pipes and all the various parts other than in polyethylene are suitable for the liquid to be contained.
- e) Avoid impacts and contact with sharp-edged objects that could compromise the integrity of the product.
- f) Only handle the tanks when they are completely empty, and then using the lifting eyes (where provided). NEVER lift the tanks by the inlet and/or outlet pipes.
- g) For the choice of backfill material and compaction methods, refer to European Standards ENV 1046 and UNI EN 1610.
- h) During the installation works, mark the boundary of the working area with suitable warning signs.

HANDLING

- a) Use transport and/or lifting equipment of adequate capacity for the load and compliant with current safety regulations when handling the material.
- b) During transport, avoid harsh movements that could compromise the integrity of the tank.
- c) Only lift the tank if it is completely empty. Never stand under a raised load.
- d) When lifting, use cables or straps suitable for the load to be supported and in perfect condition. Hook the cables or straps onto the lifting eyes present on the tanks.

To prevent the load from becoming unbalanced, place the lifting cables symmetrically, respecting the lifting angle which must NEVER be less than 45° (see figure below).

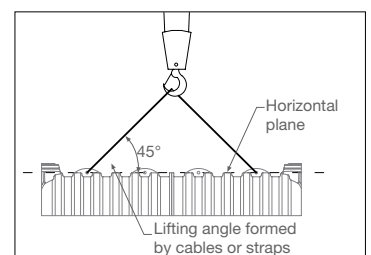

UNDERGROUND INSTALLATION

N.B. The best location for the tank is specified by the design engineer according to his own detailed technical assessment. These installation instructions provide the guidelines to follow during installation.

1. EXCAVATION

1.1 Excavate a hole of suitable dimensions with a flat bottom, leaving a space of at least 20/30 cm around the tank. In the presence of heavy ground (e.g. clayey subsoil and/or groundwater) the distance must be at least 50 cm. Spread a 15/20 cm deep layer of 20 /30 mm washed gravel on the bottom of the excavation to allow the tank to rest on a uniform and level base. Excavated material must not be used as backfill. The excavation must be a minimum of 1 m from any structures.

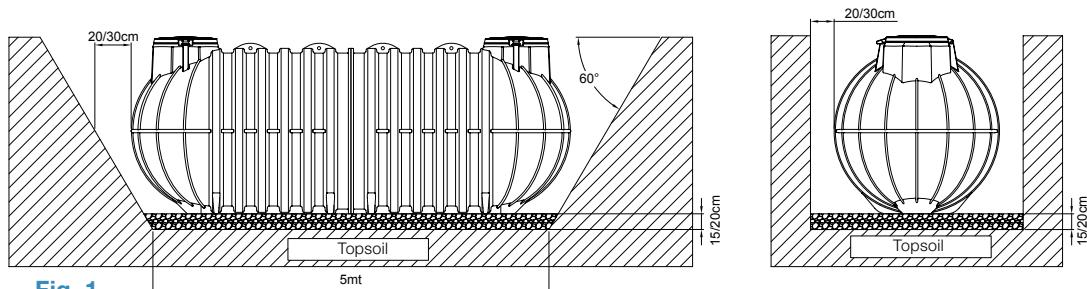

Fig. 1

2. BACKFILL AND FILLING

2.1 Place the totally empty tank on a bed of 20/30 washed gravel spread at the bottom of the excavation, gradually fill the tank with water and at the same time backfill with 20/30 washed gravel. Continue with successive layers of 15/20cm, filling the tank and then backfilling with gravel. Fill the tank to 3/4 of its capacity and backfill the last 40cm with topsoil (NOT clayey/limey material, NOT excavated material). To prevent excessive pressure on the tank, NEVER use backfill material with sharp edges.

N.B. For installation in more severe conditions (groundwater, clays soils or in sloping ground), refer to chapter 3 “Exceptional Installation”.

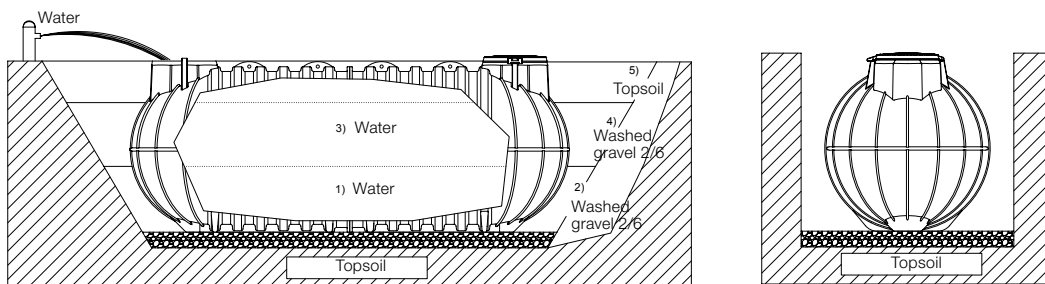

Fig. 2.1

2.2 After the tank has been filled and the excavation suitably backfilled, gradually cover with topsoil (NOT clayey/limey material, NOT excavated material) or with lightened material, e.g. expanded clay, to a depth of 30/40cm, leaving the inspection covers exposed. In this way, the area concerned is suitable for pedestrian traffic, while the transit of motor vehicles within 2m of the excavation is prohibited.

When installing treatment plants, leave the tank filled with water. However, when installing a water storage tank, leave it full of water until the ground has fully settled (minimum 7 days. This period may vary following an assessment by the designer). N.B. To render the site trafficable by motor vehicles, refer to chapter 4 “Trafficability”.

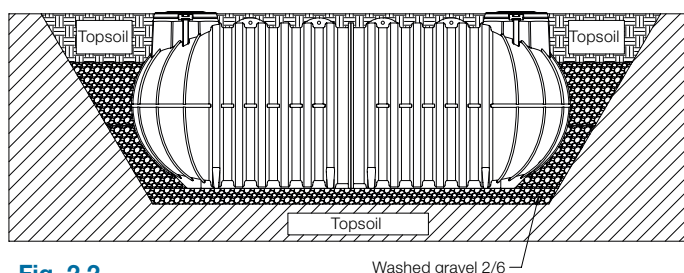

Fig. 2.2

Washed gravel 2/6

UNDERGROUND INSTALLATION

2.3 EXTENSION INSTALLATION

If the tank is installed at a depth of 30/40 cm and the site is to remain open to pedestrian traffic, it is advisable to install the Rototec PE extension directly on the inspection holes. In the case where the tank is installed deeper than that previously indicated and more than one extension needs to be installed, which constitutes an unfavourable condition and not recommended, adhere scrupulously to the instructions reported in chapter 4 "Trafficability". The technician responsible for the installation will follow the instructions reported in the two paragraphs according to the installation depth.

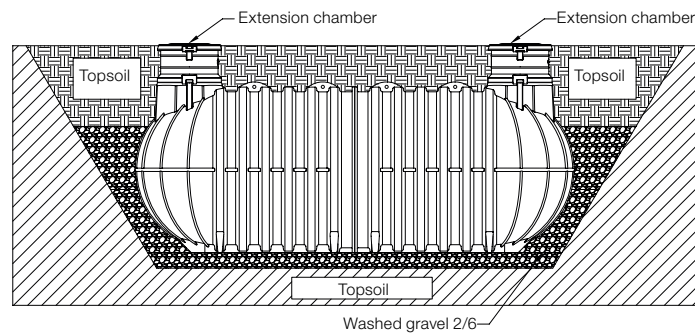

Fig. 2.3

2.4 PUMP/BIOGAS VENT CONNECTION

a) When installing a pump, whether internally or externally, ALWAYS install an open-air vent, free and correctly sized to prevent the formation of a vacuum and deformation of the tank when the pump is running. After connecting the vent, make the necessary connections and check them.

b) In order to prevent the formation of bad smells and, consequently, enable the treatment plant to function efficiently, ALWAYS connect a pipe (PVC or PE) to the connection point provided for the biogas vent on the tank. Run the pipe to the highest point of the building or along the downpipes, but in any case higher than the level of the roof.

The pipe indicated on the drawing for venting is not included in the supply.

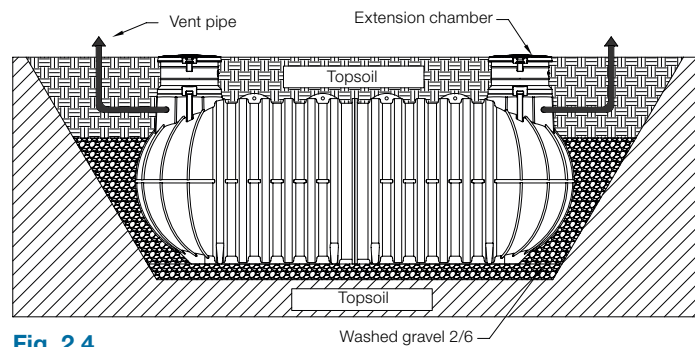

Fig. 2.4

2.5 MANHOLE INSTALLATION

The installation of manholes or covers of weight exceeding 50kg must always be solid with the concrete slab, suitably designed for the load to support and exerting a uniformly distributed load over the tank. The slab, therefore, must NOT be constructed directly on the tank but must rest on undisturbed, load-bearing ground. AVOID constructions in brickwork which would compromise maintenance and/or eventual replacement of the tank.

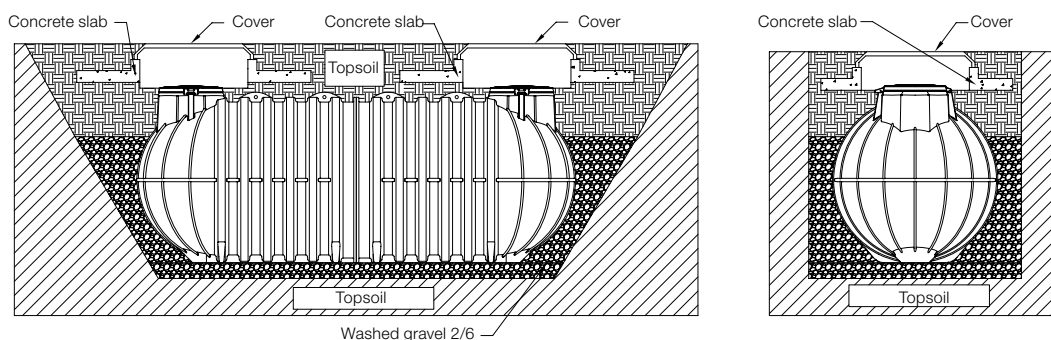

Fig. 2.5

EXCEPTIONAL INSTALLATIONS

3.1 INSTALLATION IN ZONES WITH GROUNDWATER

Installation in the presence of groundwater is not recommended as it represents one of the riskiest conditions for a storage tank. In this case, it is advisable to obtain a geotechnical report from a specialist. From the report, the installation technician will be able to define the expected pressure from the groundwater and design the backfill material and slab accordingly. In particular, he will design the backfill to have the necessary capacity for resisting the high lateral forces. The resistance capacity can be increased by inserting an electro-welded steel mesh. Construct the concrete slab at the bottom of the excavation, then spread a 10cm thick layer of 20/30 washed gravel over the top to fill in the voids between the corrugations in the base of the tank. The tank filling and backfilling operations must always be carried out progressively. It is advisable, therefore, to half fill the tank and at the same time backfill with concrete and allow it to stand for 24/36 hours [points 1-2]. Then complete the tank filling and the backfill [points 3-4].

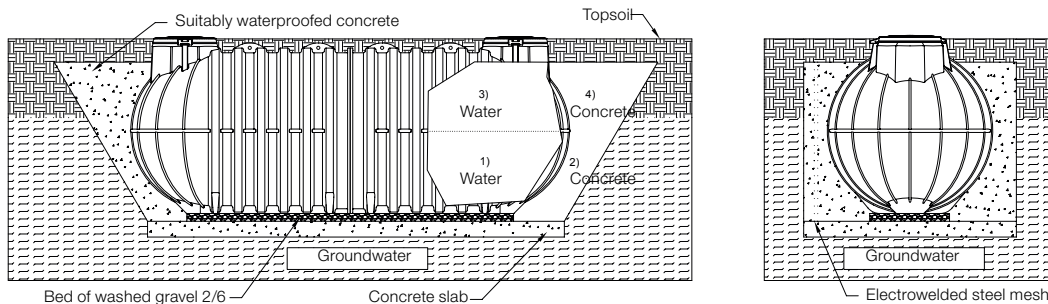

Fig. 3.1

3.2 INSTALLATION IN ZONES WITH CLAYEY/LIMEY SOIL

Installation in areas with a mainly clay/lime substrate and/or with limited drainage capacity is another unfavourable condition. A geotechnical report prepared by a specialist is advisable in this case also. From the report, the installation technician will be able to define the expected ground pressure (high in the case of clayey soil) and design the backfill accordingly. In particular, the bottom of the excavation must be covered by a bed of 20/30 washed gravel and the sides of the tank backfilled with 20/30 m gravel to aid drainage. For tank filling and backfilling, see para. 2.1. A drainage system must also be provided at the bottom of the excavation.

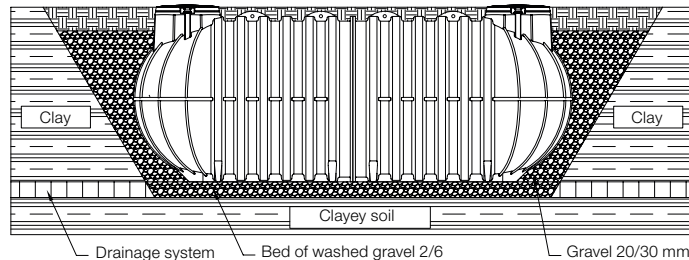

Fig. 3.2

3.3 INSTALLATION NEAR TO SLOPING GROUND

When the tank is to be installed near to a slope or on sloping ground, the tank must be protected by a reinforced concrete retaining wall, appropriately designed by a specialist, in order to balance the lateral thrust of the ground and to protect the area from possible infiltration. For tank filling and backfilling, see para. 2.1.

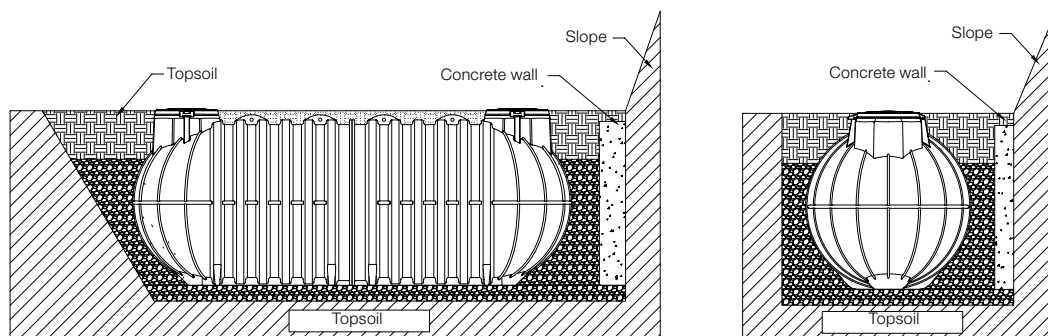

Fig. 3.3

TRAFFICABILITY

4.1 LIGHT TRAFFIC - CLASS B125-EN124/95 - MAX 12.5 TONS

To render the site suitable for the transit of light vehicles, a self-supporting reinforced concrete slab, designed in relation to the load, must be constructed. The perimeter of the slab must be larger than the excavation to prevent the weight of the slab from bearing on the tank itself. It is also advisable to construct a concrete slab (for example 15/20 cm thick) at the bottom of the excavation, over which a 10 cm thick layer of 20/30 mm washed gravel must be spread to fill in the voids between the corrugations in the base of the tank. The self-supporting slab in reinforced concrete and the bottom concrete slab must always be designed by a qualified professional. The tank filling and backfilling operations must always be carried out progressively as specified in para. 2.1.

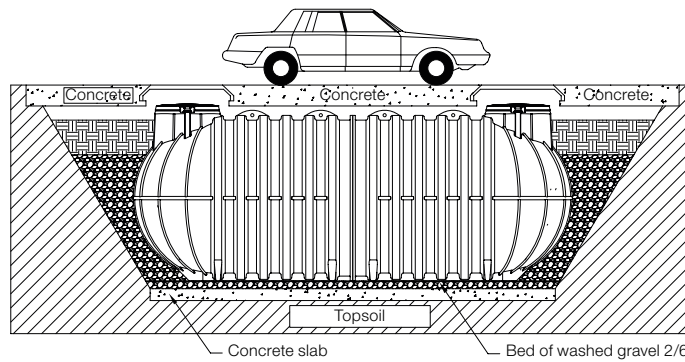

Fig. 4.1

4.2 HEAVY TRAFFIC - CLASS D400-EN124/95 - MAX 40 TONS

To render the site suitable for the transit of heavy vehicles, a reinforced concrete containment structure cast on-site with a suitable self-supporting concrete cover slab must be provided. The perimeter of the slab must be larger than the excavation in order to distribute the load on the containment walls and not on the tank itself. Then spread a 10 cm thick layer of 20/30 mm washed gravel at the bottom of the containment structure to fill in the voids between the corrugations in the base of the tank. The containment structure and cover slab must be designed by a qualified professional in relation to the expected loads. The tank filling and backfilling operations must always be carried out progressively as specified in para. 2.1.

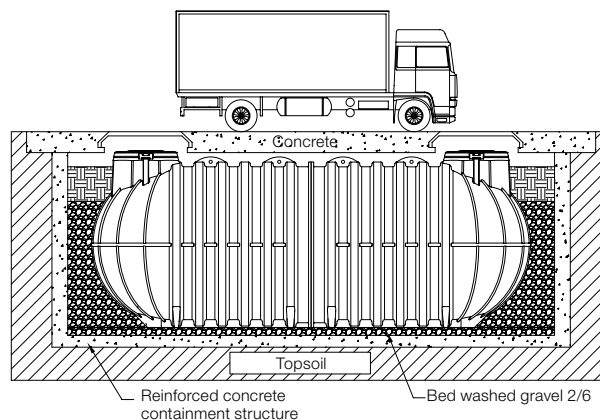

Fig. 4.2

GUARANTEE COVERING UNDERGROUND PRODUCTS

ROTOTEC S.p.A. hereby guarantees its Treatment Division tanks for underground installation, made of linear polyethylene (LLD-PE) using the rotational moulding technique, for a period of 25 years against full-depth corrosion and manufacturing defects.

This guarantee is valid on condition that the products are kept in regular service, subjected to periodic maintenance and are installed according to the methods indicated. The manufacturer will not be held liable in the event of incorrect installation.

THE GUARANTEE WILL CEASE TO BE VALID IN THE FOLLOWING CASES:

1. If the underground installation methods are not strictly adhered to.
2. If the product is modified without the prior authorisation of the manufacturer.
3. In the case of non-compliant use.

THE GUARANTEE DOES NOT COVER:

1. Installation costs.
2. Damage due to lack of use.
3. Injury to third parties.
4. Damage resulting from loss of the contents.
5. Transport costs.
6. Reinstatement of the site.

Rototec guarantees that all materials fully comply with the characteristics and conditions specified in the order confirmation and in the certificates/technical data sheet issued by the technical office.

Rototec will not be held liable for applications, installation, inspections or any operations undertaken at the buyer's premises or installation site.

The guarantee does not cover products that become defective as a result of imprudence, improper or negligent use or as the result of incorrect installation, maintenance or operation by unqualified or unauthorised persons, or following damage deriving from any other circumstances that cannot be attributed directly to defects in materials or manufacture.

Rototec will not be held liable for injury or damage either directly or indirectly deriving from incorrect installation, use or maintenance of the products sold.

Rototec products are supplied with technical data sheets, certification according to current standards and underground installation and maintenance instructions.

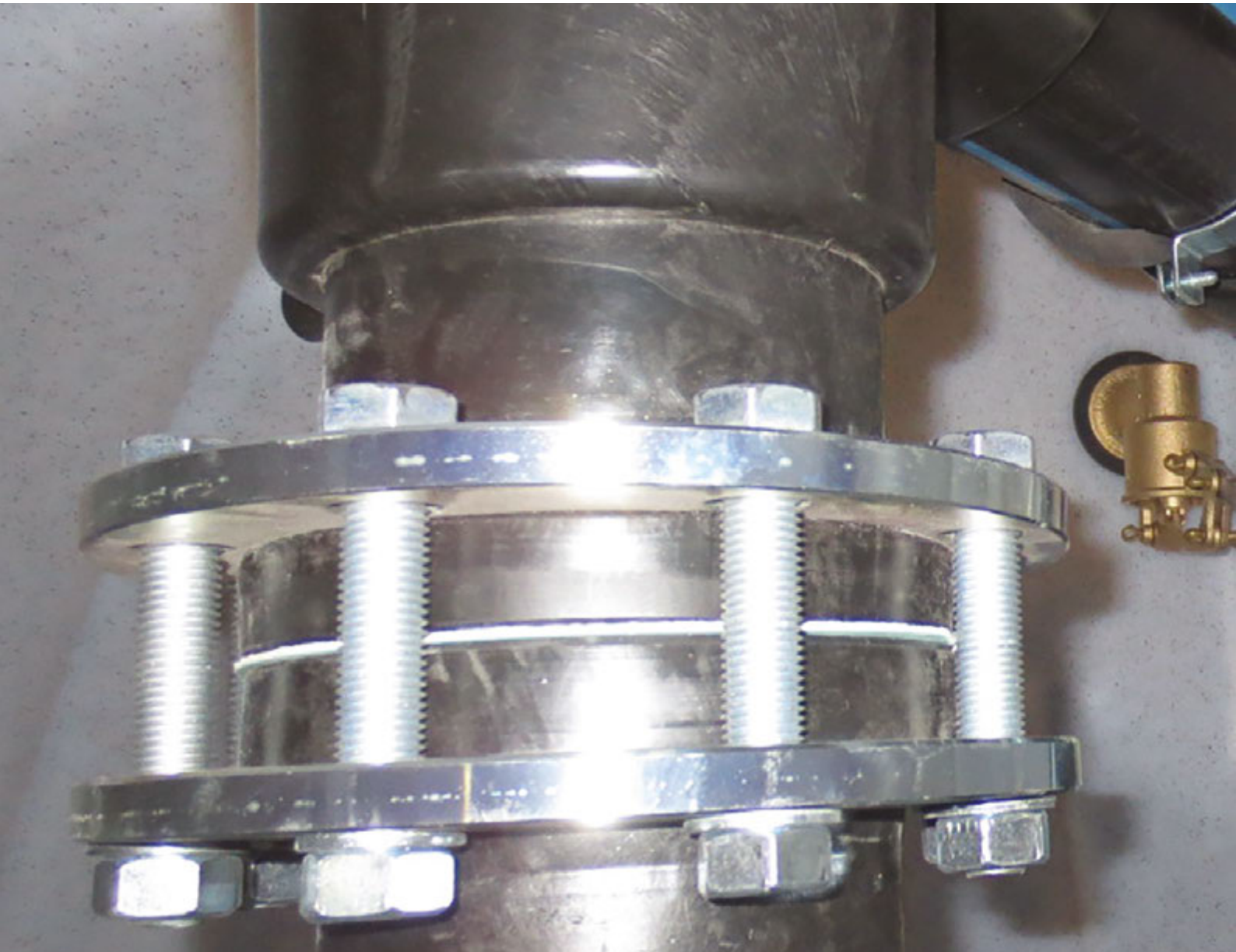

ACCESSORIES

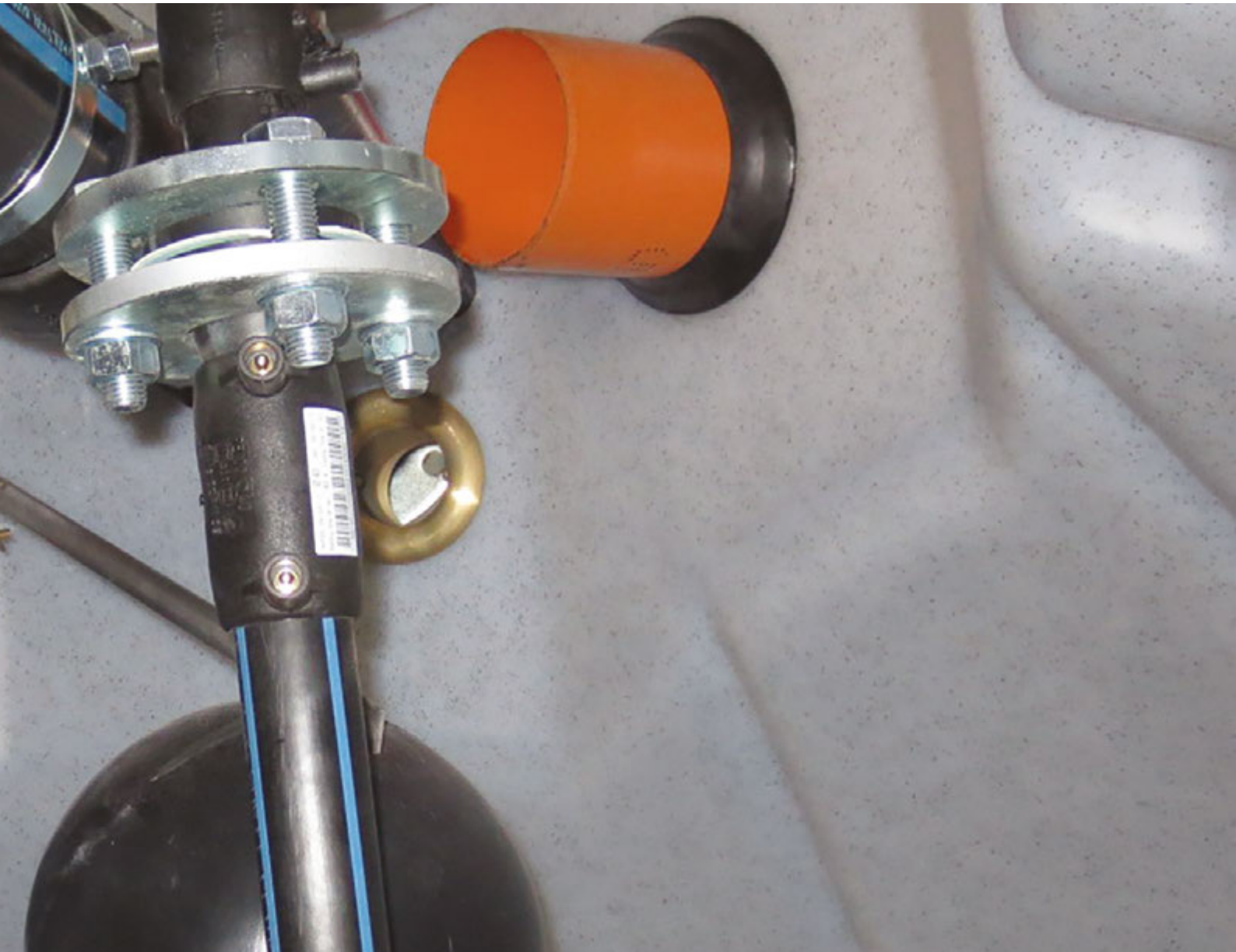

ACCESSORIES

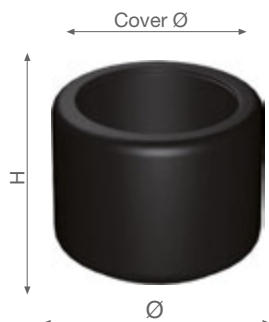

THREADED EXTENSION

Item	Ø mm	H mm	Cover Ø mm
PP30	300	300	210
PP35	435	300	300
PP35RIM	300	300	210
PP45	535	300	400
PP60RIM	535	300	400

Application: Installing the extensions enables the tops of the tanks to be located below ground level. More than one extension can be used at the same time (See chapter on Underground installation)

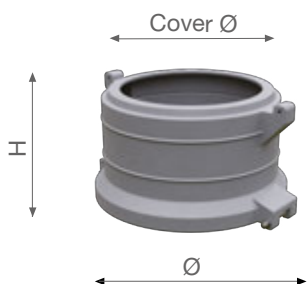

HINGED TOP EXTENSION

Item	Ø mm	H mm	Cover Ø mm
PP75	750	430	630
PP77	750	430	630
PP25	750	250	630

Application: installing the extensions enables the tops of the tanks to be located below ground level. More than one extension can be used at the same time (See chapter on Underground installation)

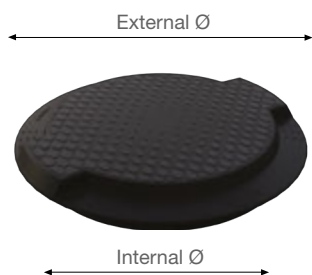

THREADED COVER IN PP*

Item	Internal Ø mm	External Ø mm
CC140	120	140
CC200	210	250
CC300	300	355
CC400	400	454
CC600	600	611

* supplied with treatment tanks

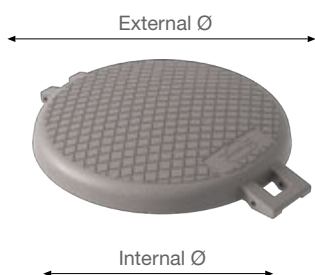

HINGED COVER IN PE

Item	Internal Ø mm	External Ø mm
TAP700*	630	800
TAP800*	630	800

* green colour available on request

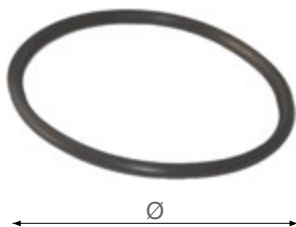

COVER GASKET

Item	Internal Ø mm	Cover model
GC255	255	CC 200 - CS 200
GC355	350	CC 300 - CS 200
GC455	460	CC 400 - CS 200
GC600	620	CC 600
GC10700	630	TAP800

Application: the gaskets are used to improve the seal between the cover and the tank manhole on underground tanks. The gaskets are fitted directly onto the threaded or hinged cover (GC10700). Material: NBR rubber (model GC10700: adhesive gasket).

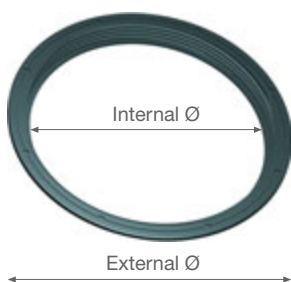

THREADED RING

Item	External Ø mm	Internal Ø mm	Tooth H mm
AF154	155	120	10
AF255	255	210	30
AF355	355	300	30
AF455	455	400	30
AF600	617	600	30

Application: the female threaded ring is installed and riveted on polyethylene tank manholes when custom inspection holes need to be created. Threaded covers can then be screwed into the rings.



GASKET

Item	External Ø mm	Internal Ø mm	L mm	Cutter Ø for gasket hole mm
GG50	95	50	8	60
GG63	110	63	8	75
GG80	125	80	8	89
GG100	145	100	8	110
GG110	150	110	8	127
GG125	160	125	10	140
GG125 S 15	160	125	13	140
GG160	200	160	10	170
GG200	230	200	10	210
GG250	280	250	10	260

Application: the rubber gaskets are used when it becomes necessary to install stub pipes on polyethylene tanks (e.g. to create inlets, outlets, etc.). When installed correctly, these gaskets provide a perfect seal.

Installation: A hole must be cut in the polyethylene tank using a circular hole cutter. The gasket is inserted in the hole. The stub pipe is then inserted in the gasket itself.

ACCESSORIES



CONNECTING PIPE IN PE

Item	Ø mm
6TRPE040S	40
6TRPE050S	50
6TRPE063S	63
6TRPE075S	75
6TRPE090S	90
6TRPE125S	125
6TRPE160S	160
6TRPE200S	200
6TRPE250S	250

Description: stub pipes in smooth HDPE, extrusion welded to form a perfect waterproof seal.

Application: when installed on the tanks, it allows the storage tank to be connected to the various draw-off systems for the liquid it contains: taps, irrigation systems, pumping systems. It also allows the tanks to be connected to each other (both underground and above-ground tanks) to provide very high storage volumes.



COMPRESSOR BLOWER

Item	Voltage V	Frequency Hz	Power W	Flow rate l/min	Noise level dB	Weight kg	Max. length mm	Max. width mm	Max. height mm
HP40	230	50	38	40	<37	5.7	250	185	190
HP60	230	50	56	60	<39	7	250	185	196
HP80	230	50	78	80	<41	7	250	185	196
HP150	230	50	145	160	<50	9	300	230	230
HP200	230	50	186	200	<50	12	300	230	250

Description: diaphragm type air compressors used in activated sludge systems to develop an aeration system necessary for the aerobic bacteria digestion processes, making use of the electromagnetic vibration of an actuator rod supported by synthetic rubber diaphragms.



SIDE CHANNEL BLOWER

Item	Voltage V	Frequency Hz	Power kW	Amps A	Noise level dB	Weight kg
HP302SF	230	50	0.7	4.5	<55	15
HP402SF	380	50	1.6	5.6	<66	24
HP502SF	380	50	3	10	<72	38

Description: compressors-aspirators constructed in accordance with the side channel principle, operating both in aspiration and in compression. They are designed to operate continuously. Constructed in die-cast aluminium to guarantee maximum sturdiness and ease of handling. Specially designed silencers contribute to its extremely low noise levels.



ELECTRIC TIMER PANEL

Item	Dimensions mm	Amps A	Power supply V
QST	210x210x100	6	230
QST3F (THREE-PHASE)	280x400x140	6	380

Description: electric panel controlling and protecting the diaphragm blowers serving activated sludge treatment plants. Thanks to the 24 hour segment timer, it is possible to set the blower to switch on and off automatically as required by the treatment plant.



ELECTRIC TIMER PANEL FOR DUAL BLOWER

Item	Dimensions mm	Amps A	Power supply V
QS2T	310x250x150	6	220

Description: electric panel controlling and protecting the diaphragm blowers serving activated sludge treatment plants. Thanks to the 24 hour segment timer, it is possible to set the blower to switch on and off automatically as required by the treatment plant.



SOCKET TIMER FOR BLOWERS

Item	Dimensions mm
TMP	70x70x40

Description: socket timer used to set the activation times of blowers-compressors. Fitted with segment timer with 15 minute intervals.



DIFFUSER PLATE

Item	ø mm	Weight kg	Max. air flow m ³ /h	ø bubbles mm	Flow rate l/min	Oxygenation capacity gO ₂ /Nm ³ per metre of head
IFADN	214	2.1	5	1-3	40	18-20

Description: diaphragm type diffusers in microbored rubber used in activated sludge plants and designed to provide a uniform distribution of air with bubbles of microscopic diameter designed to optimise performance



DIFFUSER DISC

Item	ø mm	Weight kg	Max. air flow m ³ /h	ø bubbles mm
IFADN250	250	1	5	1-3

Description: disc type membrane diffuser with rubber surface containing micro-holes that act as a valve, expanding to release air and re-closing to prevent water from entering once the flow has been interrupted.

ACCESSORIES

TUBULAR DIFFUSER



Item	Diameter	Weight kg	Length	Max. air flow m ³ /h	ø bubbles mm
IFADNT600	3"	0.9	23.5"	15.3	1-3

Description: air diffusers characterised by a rubber surface with micro-holes that act as a valve, expanding to release air and re-closing to prevent water from entering once the flow has been interrupted.

DIFFUSER KIT (IFADN)



Item	Tube length mm
IFA 1D	according to the depth of the tank
IFA 2D	according to the depth of the tank

Application: when connected to a diaphragm type blower and to one or more diffuser plates and installed inside a tank, aerates and agitates the content, either continuously or intermittently.

CHLORINE TABLET



Item	Weight mg	Diameter mm	Height mm
IFACC	200	75	25

Description: chlorine tablet consisting of trichloroisocyanuric acid with 90% active chlorine for long-lasting action. The disinfectant is released over a longer period of time (approximately 30-60 days) thanks to its particular molecular structure

FILTER MEDIA FOR PERCOLATING FILTERS



Item	Shape	Dimensions mm	Specific surface area m ² / m ³	Void index %	Dry weight kg / m ³	Weight during service kg / m ³	Material
BIOWE120	circular	170	120	approx. 95	38	approx. 350	Black isotactic polypropylene

Description: bulk filter media developed especially for the construction of medium-load percolating filter beds treating domestic or biodegradable industrial effluent. The advantages of using this type of filter media are linked to the high specific surface area and the high void index.



SINGLE DOSE BIO-ACTIVATOR SACHETS

Item	Description	Weight g
IFABIO	Single dose activator sachet for septic tanks	200

Function: biological activator in powder form, supplied in a single-dose sachet, to speed up the activation time of biological processes that normally develop in waste water treatment plants. Dissolve in a bottle of warm water and pour directly into the WC or into the tanks.



SPECIFIC CONCENTRATED BIO-ACTIVATOR

Item	Description	Weight g
IFABIODEG	Bio-activator specific for the activation of degreasers	750
IFABIOAN	Bio-activator specific for the activation of anaerobic treatment plants (septic or Imhoff tanks, anaerobic percolating filters,...)	750
IFABIOIFA	Bio-activator specific for the activation of aerobic treatment plants (activated sludge plants, aerobic percolating filters,...)	750

Function: concentrated biological activator in powder form, supplied in a 750g container, to speed up the activation time of biological processes that normally develop in sewage treatment plants. Dissolve in a bottle of warm water and pour directly into the WC or into the tanks. Available in three specific types for activation of the various tanks making up a treatment plant.

ACCESSORIES

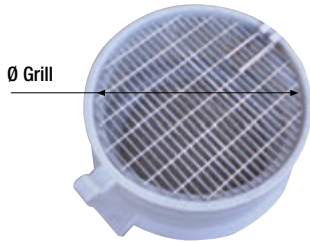

SAFETY GRILL

Item	Ø grill mm	Mesh length mm	Mesh width mm
GRANT	730	75	30

Application: the pedestrian grill is a safety device that prevents unintentional entry into the tank.
Installation: The grill is fitted directly on the underground corrugated tank inspection hatch (Cisterna, Panettone and Canotto tanks) and is fastened using the pins provided. It can be mounted directly on the tank manhole or on a hinged cover extension.



ELECTRIC FLOAT

Item	Float dimensions mm	Cable length m	Amps A	Voltage V	Protection grade	Max. temperature °C
GAL 5	80x100x40	5	10 (4)	250	IP 67	60

Application: float level switch for fresh water pump start/stop.



ONE-PIECE POLYPROPYLENE CHAMBER

Item
PM20X20G
PM20X20V
PM30X30G
PM30X30V

Application: chamber used for water drainage, as a junction inspection chamber and as an extension for grease separators with separation baffles. Supplied with polypropylene (PP) cover. Cast iron cover available on request.



ELECTROWELDABLE PE SLEEVE PN10

Item
MAN 90
MAN 125
MAN 160



OTHER PRODUCTS



SEWAGE DIVISION



- **SECONDARY TREATMENTS**
Aerobic trickle filters and constructed wetlands
- **STORMWATER RUNOFF SYSTEMS**
Gravity oil separators

WATER DIVISION

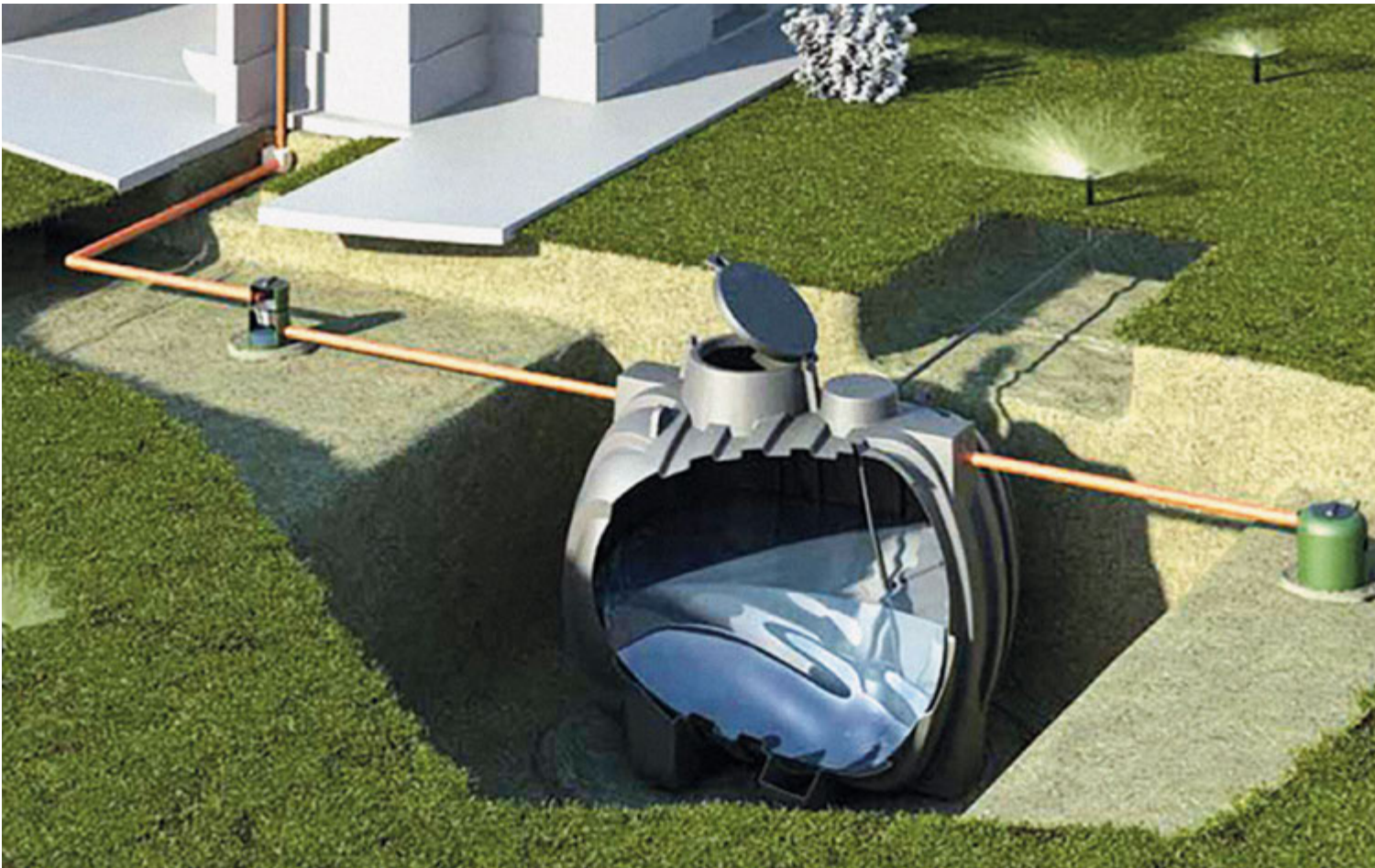

- **ABOVE GROUND TANKS**
Volumes from 50 to 14000 litres
- **UNDERGROUND TANKS**
Volumes from 1000 to 10000 litres
- **UNDERGROUND MODULAR TANK**
Volumes from 6m³ to 200 m³
- **RAINWATER HARVESTING SYSTEMS**



For more information,
see the Water Division
catalogue, available at
www.rototec.it

PORTABLE TOILETS



CHEMICAL TOILETS WITH SEAT

- Portable ONE-PIECE toilets
- Portable COLLAPSIBLE toilets
- Portable toilets for the DISABLED
- Shower cabins
- Changing cabins
- Accessories (chemical decomposing agent, deodorants...)



For more information,
see the Portable Toilets
catalogue, available at
www.rototec.it

CONSTRUCTION SITE EQUIPMENT



- **DEBRIS REMOVAL SYSTEMS**

Complete system with frame, hopper and chute

- **PERIMETER BARRIER SYSTEMS**

Road barriers, movable bollards, barriers

- **MULTI-PURPOSE BINS**

To store tools, equipment, fragile objects, etc...

- **PORTABLE TANKS**

To transport diesel and petrol (ADR exempt or ADR compliant tanks)



For more information, see the Construction Site Equipment catalogue, available at www.rototec.it

GENERAL CONDITIONS OF SALE

Premise All buyers are considered as being aware of these conditions of sale. Unless otherwise specified, all sales are effected in line with the general conditions that follow. Any orders transmitted imply the buyer's adhesion to the conditions without reservation.

Orders Purchase orders arriving by fax, e-mail or from our own sales network are always understood as being effected in accordance with the general conditions that follow and, "unless otherwise approved by the vendor", definitively accepted only on presentation of the order confirmation, which must be returned signed for acceptance.

Prices / Invoicing / Payment Each product is sold at the list price in force at the time of ordering exclusive of VAT. Our offers are provided without obligation and, unless expressly indicated, are governed by these general conditions of sale. A validity period is specified for the offers which are available for the time period fixed. The products will be invoiced within the reference month of the delivery at the prices in force at the time of ordering and with the application of the VAT in force on the date of invoicing. The invoice will be made out in the same name as the order and will be issued in accordance with current tax legislation. It will, therefore, be the buyer's responsibility, at the time of ordering and prior to the issue of the invoice, to check and inform the vendor of any variations or additions that may modify the information in the possession of Rototec. Payment for the supply will be made adopting the methods and times provided for in the order confirmation. Delays in the payment, including partial, of the invoices and any extra-contractual renewal of the effects will give rise to interest on arrears at the official discount rate increased by 3 points. Furthermore, any stamp charges will be totally at the cost of the customer. Delayed or non-payment of the invoices will give Rototec the right to request advance payment for any remaining orders or contracts in course, and to consider them rescinded, or suspend or annul them, without the buyer having any right to demand compensation, damages or reservations on the matter.

Ownership of goods The ownership of the goods is transferred to the buyer on receipt of the final balance of the agreed price.

Claims Any claims must be forwarded in writing at the time of unloading of the goods and with an entry on the delivery note. When reporting concealed defects, all necessary documentation required by Rototec technicians (photographs, reports, etc.) for the determination of that disputed must also be sent. Following an assessment by Rototec technicians, if the complaint is deemed as valid, excluding that for which Rototec is not answerable under the terms of the guarantee described below, the company's obligation is limited to replacing the goods at the same place of delivery of the initial supply and subject to the return of the faulty items. The buyer has no rights whatsoever to request the termination of the contract or a reduction in price, or compensation for damages or reimbursement of any costs sustained whatsoever. Claims do not give the buyer any right to suspend payment of the invoice for the contested goods.

Shipping / Transport / Packing / Terms of delivery Rototec products do not require packing unless otherwise specified at the time of order confirmation. The goods are intended as delivered "free ex works". Unless otherwise agreed on the order confirmation, the goods are delivered free to destination in the case of orders of not less than 1,000.00, net of any discounts. For orders below this amount, Rototec, when in agreement with the buyer, is willing to organise transport free to destination, debiting the transport costs according to the volume of the goods and according to the list price of the transporter as indicated on the order confirmation. The goods are transported at the risk of the customer, including when sold free port and transported using Rototec vehicles. Destinations of goods other than the registered/administrative offices of the company must be indicated at the time of ordering. The contact person and the respective telephone numbers to call at the time of delivery must also be indicated. The buyer is also responsible for ensuring that all the requirements for receiving and unloading the goods have been met. Rototec will not be held liable for damage occurring during the transport of the goods, as a result of which their condition must be verified on receipt. Any claims or disputes arising from product defects must be made immediately on unloading

and must be reported on the delivery note, and then sent to Rototec via fax or e-mail in order that the company can take the necessary action. The delivery times indicated in the offer and on the order confirmation are purely indicative. Under no circumstances can any delays in delivery lead to the payment of damages or cancellation, even partial, of the contract, that is unless these conditions have been expressly accepted by the company at the time of contract signing or order confirmation. In all cases, delivery time and organisation of the shipment will be undertaken with the due care and in line with experience, with communication to the customer when the goods are ready for shipment.

Guarantee Rototec guarantees that all materials fully comply with the characteristics and conditions specified in the order confirmation and in the certificates/technical data sheet issued by the technical office. Rototec will not be held liable for applications, installation, inspections or any operations undertaken at the buyer's premises or installation site. Any products with defects resulting from carelessness, incompetence or negligence during use or due to incorrect installation or maintenance by unauthorised or unqualified personnel, or damage caused as a result of circumstances that cannot be traced back to fabrication defects, are not covered by the guarantee. Rototec will not be held liable for injury or damage either directly or indirectly deriving from incorrect installation, use or maintenance of the products sold. Rototec products are supplied with technical data sheets, certification in accordance with current legislation and installation and maintenance instructions developed with the due care and know-how. The customer is informed when the goods are ready for shipment.

Force majeure In cases of force majeure and any other provided for by law, including red alerts, mobilisation, war, fire, occupation of works, etc. or any other impediment that is not the fault of Rototec, the buyer does not have any right to receive damages, compensation or reimbursement and must, where requested, pay for any finished or partly finished products.

Court of Competent Jurisdiction The buyer agrees that any disputes relating to the application, interpretation and execution of this contract fall within the jurisdiction of the Urbino Law Courts.

WARNING!

WHEN INSTALLING UNDERGROUND TANKS, THE INSTRUCTIONS SUPPLIED BY THE COMPANY MUST BE SCRUPULOUSLY FOLLOWED

The data reported in this price list is purely indicative. ROTOTEC reserves the right to modify or improve the products illustrated without prior notification. ROTOTEC can make its technical office available for the design and realisation of customised products and/or for satisfying the particular needs of its clientele. Dimensional tolerance $\pm 3\%$, capacity tolerance $\pm 5\%$.



Rototec S.p.A

Via dell'Artigianato, 6 / 61026 Lunano (PU)
tel. (+39) 0722 7228 / fax. (+39) 0722 70599

www.rototec.it / info@rototec.it

